

PUSH-CART, CARTILLA TYPE

DESIGN	
	Heavy Duty Foldable Push-cart
DIMENSIONS	
	24 inches (W) x 36 inches (L) x 34 inches (H) (610mm W x 920mm L x 870mm H)
LOADING CAPACITY	
	300 kg. (660 lbs.)
CONSTRUCTION	
Caster:	
	5 inches (130mm) dia. Elastic Rubber Wheels (S24) with double ball bearing
	4 Wheels (2 Swivel & 2 Fixed)
Loading Face:	
	24 inches (W) x 36 inches (L) (610mm W x 920mm L)
Platform:	
	Heavy duty Steel Platform with reinforcing channels on underside
Handle:	
	Tubular Steel Handle folds down against the platform



PRICE (VAT INCLUSIVE): P 12,000.00

STANCHION WITH RETRACTABLE BELT BARRIER

DESIGN	
Stainless Steel Stanchion with Retractable belt barrier with locking belt pivot ends and four way belt end system, mirror polished finished with flat base and light blue color belt	
CONSTRUCTION	
Material	0.8mm thick Stainless Steel
Height (Floor to top of post assembly)	38.5 inches (975mm)
Post Diameter	2.0 inches (51mm)
Flat Base Diameter	12.6 inches (320mm)
Flat Base Height	2.0 inches (51mm)
Weight	17.5 lbs (8kgs)
Belt Length	78.0 inches (2000mm)
Base Cover	Round Flat base
COLOR/FINISHED	
Post and Base	Mirror Polished
Belt	Light Blue

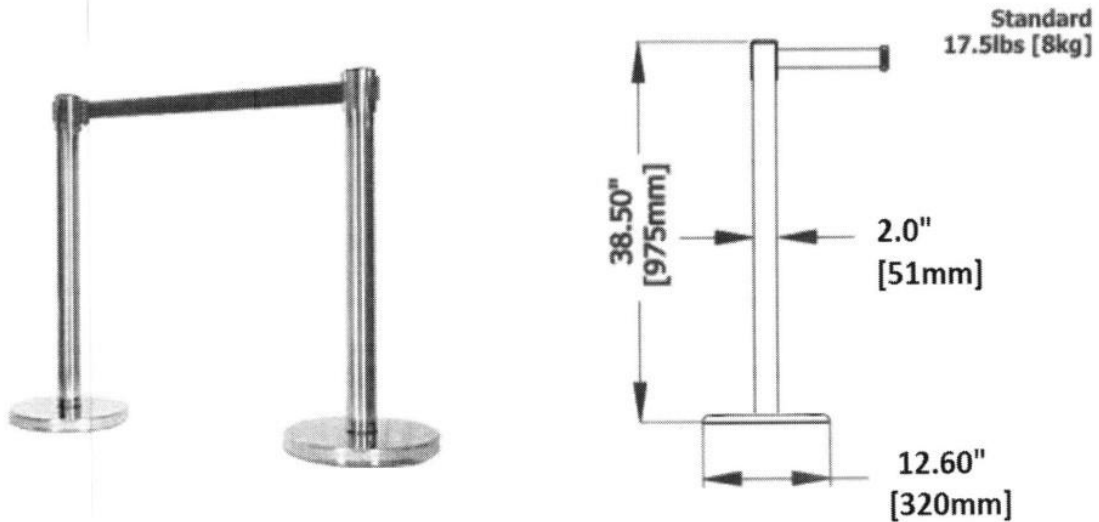

per set = 2 posts and 2 belts

PRICE (VAT INCLUSIVE): P 5,376.00 (per set)