



SOCIAL SECURITY SYSTEM

PHILIPPINE BIDDING DOCUMENTS

Sixth Edition

Procurement of GOODS

**MODULAR FURNITURE FOR
CCD, MAD AND OVP-PASED**

ITB-SSS-GOODS-2022-006

DECEMBER 2021

Government of the Republic of the Philippines

A handwritten signature in blue ink, appearing to read 'Marichelle J. Aguilar'.

Marichelle J. Aguilar

TWG Chairperson

Table of Contents

Glossary of Acronyms, Terms, and Abbreviations	3
Section I. Invitation to Bid.....	7
Section II. Instructions to Bidders.....	9
1. Scope of Bid	10
3. Bidding Requirements	10
4. Corrupt, Fraudulent, Collusive, and Coercive Practices	10
5. Eligible Bidders.....	10
6. Origin of Goods	11
7. Subcontracts	11
8. Pre-Bid Conference	11
9. Clarification and Amendment of Bidding Documents	11
10. Documents comprising the Bid: Eligibility and Technical Components	11
11. Documents comprising the Bid: Financial Component	11
12. Bid Prices	12
13. Bid and Payment Currencies	12
14. Bid Security	12
15. Sealing and Marking of Bids	12
16. Deadline for Submission of Bids	13
17. Opening and Preliminary Examination of Bids	13
18. Domestic Preference	13
19. Detailed Evaluation and Comparison of Bids	13
20. Post-Qualification	14
21. Signing of the Contract	14
Section III. Bid Data Sheet	15
Section IV. General Conditions of Contract.....	18
1. Scope of Contract	19
2. Advance Payment and Terms of Payment	19
3. Performance Security	19
4. Inspection and Tests	19
5. Warranty	19
6. Liability of the Supplier	20
Section V. Special Conditions of Contract	21
Section VI. Schedule of Requirements	29
Section VII. Technical Specifications	30
Section VIII. Checklist of Technical and Financial Documents	47



Glossary of Acronyms, Terms, and Abbreviations

ABC – Approved Budget for the Contract.

BAC – Bids and Awards Committee.

Bid – A signed offer or proposal to undertake a contract submitted by a bidder in response to and in consonance with the requirements of the bidding documents. Also referred to as *Proposal* and *Tender*. (2016 revised IRR, Section 5[c])

Bidder – Refers to a contractor, manufacturer, supplier, distributor and/or consultant who submits a bid in response to the requirements of the Bidding Documents. (2016 revised IRR, Section 5[d])

Bidding Documents – The documents issued by the Procuring Entity as the bases for bids, furnishing all information necessary for a prospective bidder to prepare a bid for the Goods, Infrastructure Projects, and/or Consulting Services required by the Procuring Entity. (2016 revised IRR, Section 5[e])

BIR – Bureau of Internal Revenue.

BSP – BangkoSentral ng Pilipinas.

Consulting Services – Refer to services for Infrastructure Projects and other types of projects or activities of the GOP requiring adequate external technical and professional expertise that are beyond the capability and/or capacity of the GOP to undertake such as, but not limited to: (i) advisory and review services; (ii) pre-investment or feasibility studies; (iii) design; (iv) construction supervision; (v) management and related services; and (vi) other technical services or special studies. (2016 revised IRR, Section 5[i])

CDA - Cooperative Development Authority.

Contract – Refers to the agreement entered into between the Procuring Entity and the Supplier or Manufacturer or Distributor or Service Provider for procurement of Goods and Services; Contractor for Procurement of Infrastructure Projects; or Consultant or Consulting Firm for Procurement of Consulting Services; as the case may be, as recorded in the Contract Form signed by the parties, including all attachments and appendices thereto and all documents incorporated by reference therein.

CIF – Cost Insurance and Freight.

CIP – Carriage and Insurance Paid.

CPI – Consumer Price Index.

DDP – Refers to the quoted price of the Goods, which means “delivered duty paid.”

DTI – Department of Trade and Industry.

EXW – Ex works.

FCA – “Free Carrier” shipping point.

FOB – “Free on Board” shipping point.



Foreign-funded Procurement or Foreign-Assisted Project—Refers to procurement whose funding source is from a foreign government, foreign or international financing institution as specified in the Treaty or International or Executive Agreement. (2016 revised IRR, Section 5[b]).

Framework Agreement – Refers to a written agreement between a procuring entity and a supplier or service provider that identifies the terms and conditions, under which specific purchases, otherwise known as “Call-Offs,” are made for the duration of the agreement. It is in the nature of an option contract between the procuring entity and the bidder(s) granting the procuring entity the option to either place an order for any of the goods or services identified in the Framework Agreement List or not buy at all, within a minimum period of one (1) year to a maximum period of three (3) years. (GPPB Resolution No. 27-2019)

GFI – Government Financial Institution.

GOCC –Government-owned and/or –controlled corporation.

Goods – Refer to all items, supplies, materials and general support services, except Consulting Services and Infrastructure Projects, which may be needed in the transaction of public businesses or in the pursuit of any government undertaking, project or activity, whether in the nature of equipment, furniture, stationery, materials for construction, or personal property of any kind, including non-personal or contractual services such as the repair and maintenance of equipment and furniture, as well as trucking, hauling, janitorial, security, and related or analogous services, as well as procurement of materials and supplies provided by the Procuring Entity for such services. The term “related” or “analogous services” shall include, but is not limited to, lease or purchase of office space, media advertisements, health maintenance services, and other services essential to the operation of the Procuring Entity. (2016 revised IRR, Section 5[r])

GOP – Government of the Philippines.

GPPB – Government Procurement Policy Board.

INCOTERMS – International Commercial Terms.

Infrastructure Projects – Include the construction, improvement, rehabilitation, demolition, repair, restoration or maintenance of roads and bridges, railways, airports, seaports, communication facilities, civil works components of information technology projects, irrigation, flood control and drainage, water supply, sanitation, sewerage and solid waste management systems, shore protection, energy/power and electrification facilities, national buildings, school buildings, hospital buildings, and other related construction projects of the government. Also referred to as *civil works or works*. (2016 revised IRR, Section 5[u])

LGUs – Local Government Units.

NFCC – Net Financial Contracting Capacity.

NGA – National Government Agency.

PhilGEPS - Philippine Government Electronic Procurement System.

Procurement Project – refers to a specific or identified procurement covering goods, infrastructure project or consulting services. A Procurement Project shall be described, detailed, and scheduled in the Project Procurement Management Plan prepared by the agency which shall be consolidated in the procuring entity's Annual Procurement Plan. (GPPB Circular No. 06-2019 dated 17 July 2019)

PSA – Philippine Statistics Authority.

SEC – Securities and Exchange Commission.

SLCC – Single Largest Completed Contract.

SSS – Social Security System



Supplier – refers to a citizen, or any corporate body or commercial company duly organized and registered under the laws where it is established, habitually established in business and engaged in the manufacture or sale of the merchandise or performance of the general services covered by his bid. (Item 3.8 of GPPB Resolution No. 13-2019, dated 23 May 2019). Supplier as used in these Bidding Documents may likewise refer to a distributor, manufacturer, contractor, or consultant.

UN – United Nations.



Section I. Invitation to Bid



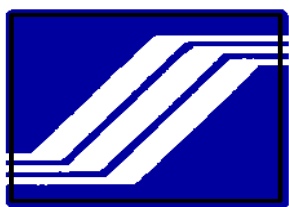

REPUBLIC OF THE PHILIPPINES
SOCIAL SECURITY SYSTEM

East Avenue, Diliman, Quezon City
Tel. Nos. (632)8709-7198*(632)8920-6446

E-mail: member_relations@sss.gov.ph*Website <http://www.sss.gov.ph>

Invitation to Bid
ITB-SSS-Goods-2022-006

MODULAR FURNITURE FOR CCD, MAD AND OVP PASED

Approved Budget for the Contract (ABC) & Source of Fund	Delivery/ Completion Period	Price of Bid Documents (non-refundable)	Schedule of Activities Date/Time	
			Pre-bid Conference	Deadline of submission and receipt of bids
₱ 2,669,638.72 Approved 2022 Corporate Operating Budget – CAPEX with code PAP (2022-116) of the Annual Procurement Plan (APP)	Sixty (60) calendar days from receipt of Notice to Proceed and Signed Contract	P 3,000.00	January 5, 2022 (Wednesday) 2:30pm	January 26, 2022 (Wednesday) 2:00pm

1. The **SOCIAL SECURITY SYSTEM** now invites Bids for the above item. Delivery of the Goods is required within the period specified above. **Bidders should have completed within five (5) years prior to the date of submission and receipt of bids**, a contract similar to the Project. The description of an eligible Bidder is contained in the Bidding Documents, particularly, in Section II - Instruction to Bidders.
2. Bids received in excess of the ABC shall be automatically rejected at bid opening.
3. Bidding will be conducted through open competitive bidding procedures using a non-discretionary pass/fail criterion as specified in the 2016 Revised Implementing Rules and Regulations (RIRR) of Republic Act 9184 (RA) 9184, otherwise known as the “Government Procurement Reform Act”.

Bidding is restricted to Filipino citizens/sole proprietorships, partnerships, or organizations with at least sixty percent (60%) interest or outstanding capital stock belonging to citizens of the Philippines, and to citizens or organizations of a country the laws or regulations of which grant similar rights or privileges to Filipino citizens, pursuant to RA 5183.

4. Interested bidders may obtain further information from the SSS and inspect the Bidding Documents at the address in the last item of the ITB from Monday to Friday, 8:00 a.m. to 5:00 p.m.
5. A complete set of Bidding Documents may be acquired by interested bidders starting **27 December 2021 up to the scheduled submission & receipt of bids** from the address stated in the last item of the ITB and upon payment of the applicable fee for the Bidding Documents in the amount specified above.

The mode of payment will be on a cash basis payable at the SSS Cash Department, Ground Floor, SSS Main Bldg., upon accomplishment of SSS Form R-6. The Bidding Documents shall be received personally by the prospective Bidder or his authorized representative.

It may also be downloaded free of charge from the website of the Philippine Government Electronic Procurement System (PhilGEPS) and the website of the SSS, provided that Bidders shall pay the applicable fee for the Bidding Documents not later than the submission of their bids.

6. The SSS will hold a Pre-Bid Conference on the date and time specified above at the Bidding Room, 2nd Floor, SSS Main Bldg., East Avenue, Diliman, Quezon City which shall be open to prospective bidders, but attendance shall not be mandatory. To ensure completeness and compliance of bids, bidders are advised to send their authorized technical and/or administrative representatives who will prepare the bid documents.

The Pre-Bid Conference will be conducted through online conference using Microsoft Teams. Kindly e-mail us on or before 04 January 2022, through e-mail address bac@sss.gov.ph, the following:

- a. Name of the representative and e-mail address; and
- b. Technical and administrative queries.



7. Bids must be duly received by the BAC Secretariat at the Bidding Room, 2nd Floor, SSS Main Building, East Avenue, Diliman, Quezon City on the deadline specified above. All Bids must be accompanied by a bid security in any of the acceptable forms and in the amount stated in the ITB Clause 14.

Bid opening shall be on the date and time specified above at the Bidding Room, 2nd Floor, SSS Main Building, East Avenue, Diliman, Quezon City. Bids will be opened in the presence of the bidders' representatives who choose to attend at the address above. Late bids shall not be accepted.

8. References to the dates and times shall be based on Philippine Standard time. Should any of the above dates fall on a holiday, the deadline shall be extended to the same time of the immediately succeeding business day in Quezon City.
9. The SSS reserves the right to reject any and all bids, declare a failure of bidding, or not award the contract at any time prior to contract award in accordance with Sections 35.6 and 41 of the 2016 revised IRR of RA No. 9184, without thereby incurring any liability to the affected bidder or bidders.
10. The SSS assumes no obligation to compensate or indemnify parties for any expense or loss that they may incur as a result of their participation in the procurement process, nor does SSS guarantee that an award will be made as a result of this invitation. Furthermore, the SSS reserves the right to waive any defects or formality in the responses to the eligibility requirements and to this invitation and reserves the right to accept the proposal most advantageous to the agency.
11. For further information, please refer to:

Bids & Awards Committee
The Secretariat
2ndFlr., SSS Main Bldg., East Ave., Diliman, Q.C.
Tel # (632) 8922-1070; 8709-7198 local 5492/6382
Email – bac@sss.gov.ph

12. Bidding Documents may be downloaded from PROCUREMENT tab at www.sss.gov.ph starting **27 December 2021**.

CS211224502
THE CHAIRPERSON
BIDS & AWARDS COMMITTEE

ref.: itb-sss-goods-2022-006-SDI of Furniture for CCD/MAD/OVP-PASED



Section II. Instructions to Bidders



1. Scope of Bid

The Procuring Entity, *Social Security System* wishes to receive Bids for the Modular Furniture for CCD, MAD and OVP PASED which covers supply, delivery and installation with identification number ITB-SSS-Goods-2022-006.

The Procurement Project (referred to herein as “Project”) is composed of single lot, the details of which are described in Section VII (Technical Specifications).

2. Funding Information

- 2.1. The GOP through the source of funding as indicated below for CY2022 in the amount of Two Million Six Hundred Sixty-Nine Thousand Six Hundred Thirty-Nine Pesos (₱ 2,669,639.00).
- 2.2. The source of funding is: Approved 2022 Corporate Operating Budget – CAPEX with code PAP (2022-116) of the Annual Procurement Plan (APP)

3. Bidding Requirements

The Bidding for the Project shall be governed by all the provisions of RA No. 9184 and its 2016 revised IRR, including its Generic Procurement Manuals and associated policies, rules and regulations as the primary source thereof, while the herein clauses shall serve as the secondary source thereof.

Any amendments made to the IRR and other GPPB issuances shall be applicable only to the ongoing posting, advertisement, or **IB** by the BAC through the issuance of a supplemental or bid bulletin.

The Bidder, by the act of submitting its Bid, shall be deemed to have verified and accepted the general requirements of this Project, including other factors that may affect the cost, duration and execution or implementation of the contract, project, or work and examine all instructions, forms, terms, and project requirements in the Bidding Documents.

4. Corrupt, Fraudulent, Collusive, and Coercive Practices

The Procuring Entity, as well as the Bidders and Suppliers, shall observe the highest standard of ethics during the procurement and execution of the contract. They or through an agent shall not engage in corrupt, fraudulent, collusive, coercive, and obstructive practices defined under Annex “I” of the 2016 revised IRR of RA No. 9184 or other integrity violations in competing for the Project.

5. Eligible Bidders

- 5.1. Only Bids of Bidders found to be legally, technically, and financially capable will be evaluated.
- 5.2. Foreign ownership limited to those allowed under the rules may participate in this Project.
- 5.3. Pursuant to Section 23.4.1.3 of the 2016 revised IRR of RA No.9184, the Bidder shall have an SLCC that is at least one (1) contract similar to the Project the value of which, adjusted to current prices using the PSA’s CPI, must be at least equivalent to:
 - a. The Bidder must have completed a single contract that is similar to this Project, equivalent to at least fifty percent (50%) of the ABC.
- 5.4. The Bidders shall comply with the eligibility criteria under Section 23.4.1 of the 2016 IRR of RA No. 9184.



6. Origin of Goods

There is no restriction on the origin of goods other than those prohibited by a decision of the UN Security Council taken under Chapter VII of the Charter of the UN, subject to Domestic Preference requirements under **ITB** Clause 18.

7. Subcontracts

7.1. The Procuring Entity has prescribed that Subcontracting is not allowed.

8. Pre-Bid Conference

The Procuring Entity will hold a pre-bid conference for this Project on the specified date and time and either at its physical address **Bidding Room, 2nd Floor, SSS Main Building, East Avenue, Diliman, Quezon City** and/or through online conference using **Microsoft Teams** as indicated in paragraph 6 of the **IB**.

9. Clarification and Amendment of Bidding Documents

Prospective bidders may request for clarification on and/or interpretation of any part of the Bidding Documents. Such requests must be in writing and received by the Procuring Entity, either at its given address or through electronic mail indicated in the **IB**, at least ten (10) calendar days before the deadline set for the submission and receipt of Bids.

10. Documents comprising the Bid: Eligibility and Technical Components

- 10.1. The first envelope shall contain the eligibility and technical documents of the Bid as specified in **Section VIII (Checklist of Technical and Financial Documents)**.
- 10.2. The Bidder's SLCC as indicated in **ITB** Clause 5.3 should have been completed within **the last five (5) years** prior to the deadline for the submission and receipt of bids.
- 10.3. If the eligibility requirements or statements, the bids, and all other documents for submission to the BAC are in foreign language other than English, it must be accompanied by a translation in English, which shall be authenticated by the appropriate Philippine foreign service establishment, post, or the equivalent office having jurisdiction over the foreign bidder's affairs in the Philippines. Similar to the required authentication above, for Contracting Parties to the Apostille Convention, only the translated documents shall be authenticated through an apostille pursuant to GPPB Resolution No. 13-2019 dated 23 May 2019. The English translation shall govern, for purposes of interpretation of the bid.

11. Documents comprising the Bid: Financial Component

- 11.1. The second bid envelope shall contain the financial documents for the Bid as specified in **Section VIII (Checklist of Technical and Financial Documents)**.
- 11.2. If the Bidder claims preference as a Domestic Bidder or Domestic Entity, a certification issued by DTI shall be provided by the Bidder in accordance with Section 43.1.3 of the 2016 revised IRR of RA No. 9184.
- 11.3. Any bid exceeding the ABC indicated in paragraph 1 of the **IB** shall not be accepted.
- 11.4. For Foreign-funded Procurement, a ceiling may be applied to bid prices provided the conditions are met under Section 31.2 of the 2016 revised IRR of RA No. 9184.



12. Bid Prices

- 12.1. Prices indicated on the Price Schedule shall be entered separately in the following manner:
- a. For Goods offered from within the Procuring Entity's country:
 - i. The price of the Goods quoted EXW (ex-works, ex-factory, ex-warehouse, ex-showroom, or off-the-shelf, as applicable);
 - ii. The cost of all customs duties and sales and other taxes already paid or payable;
 - iii. The cost of transportation, insurance, and other costs incidental to delivery of the Goods to their final destination; and
 - iv. The price of other (incidental) services, if any, listed in the **BDS**.
 - b. For Goods offered from abroad:
 - i. Unless otherwise stated in the **BDS**, the price of the Goods shall be quoted delivered duty paid (DDP) with the place of destination in the Philippines as specified in the **BDS**. In quoting the price, the Bidder shall be free to use transportation through carriers registered in any eligible country. Similarly, the Bidder may obtain insurance services from any eligible source country.
 - ii. The price of other (incidental) services, if any, as listed in the **BDS**.

13. Bid and Payment Currencies

- 13.1. For Goods that the Bidder will supply from outside the Philippines, the bid prices may be quoted in the local currency or tradeable currency accepted by the BSP at the discretion of the Bidder. However, for purposes of bid evaluation, Bids denominated in foreign currencies, shall be converted to Philippine currency based on the exchange rate as published in the BSP reference rate bulletin on the day of the bid opening.
- 13.2. Payment of the contract price shall be made in Philippine Pesos.

14. Bid Security

- 14.1. The Bidder shall submit a Bid Securing Declaration or any form of Bid Security in the amount indicated in the **BDS**, which shall be not less than the percentage of the ABC in accordance with the schedule in the **BDS**.
- 14.2. The Bid and bid security shall be valid for **One Hundred Twenty (120) Calendar Days from the Date of the Bid Opening**. Any Bid not accompanied by an acceptable bid security shall be rejected by the Procuring Entity as non-responsive.

15. Sealing and Marking of Bids

Each Bidder shall submit one copy of the first and second components of its Bid.

The Procuring Entity may request additional hard copies and/or electronic copies of the Bid. However, failure of the Bidders to comply with the said request shall not be a ground for disqualification.



If the Procuring Entity allows the submission of bids through online submission or any other electronic means, the Bidder shall submit an electronic copy of its Bid, which must be digitally signed. An electronic copy that cannot be opened or is corrupted shall be considered non-responsive and, thus, automatically disqualified.

16. Deadline for Submission of Bids

- 16.1. The Bidders shall submit on the specified date and time and either at its physical address or through online submission as indicated in paragraph 7 of the **IB**.

17. Opening and Preliminary Examination of Bids

- 17.1. The BAC shall open the Bids in public at the time, on the date, and at the place specified in paragraph 7 of the **IB**. The Bidders' representatives who are present shall sign a register evidencing their attendance. In case videoconferencing, webcasting or other similar technologies will be used, attendance of participants shall likewise be recorded by the BAC Secretariat.

In case the Bids cannot be opened as scheduled due to justifiable reasons, the rescheduling requirements under Section 29 of the 2016 revised IRR of RA No. 9184 shall prevail.

- 17.2. The preliminary examination of bids shall be governed by Section 30 of the 2016 revised IRR of RA No. 9184.

18. Domestic Preference

- 18.1. The Procuring Entity will grant a margin of preference for the purpose of comparison of Bids in accordance with Section 43.1.2 of the 2016 revised IRR of RA No. 9184.

19. Detailed Evaluation and Comparison of Bids

- 19.1. The Procuring BAC shall immediately conduct a detailed evaluation of all Bids rated "*passed*," using non-discretionary pass/fail criteria. The BAC shall consider the conditions in the evaluation of Bids under Section 32.2 of the 2016 revised IRR of RA No. 9184.

- 19.2. If the Project allows partial bids, bidders may submit a proposal on any of the lots or items, and evaluation will be undertaken on a per lot or item basis, as the case maybe. In this case, the Bid Security as required by **ITB** Clause 14 shall be submitted for each lot or item separately.

- 19.3. The descriptions of the lots or items shall be indicated in **Section VII (Technical Specifications)**, although the ABCs of these lots or items are indicated in the **BDS** for purposes of the NFCC computation pursuant to Section 23.4.2.6 of the 2016 revised IRR of RA No. 9184. The NFCC must be sufficient for the total of the ABCs for all the lots or items participated in by the prospective Bidder.

- 19.4. The Project shall be awarded as follows:

One Project having several items that shall be awarded as one contract.

- 19.5. Except for bidders submitting a committed Line of Credit from a Universal or Commercial Bank in lieu of its NFCC computation, all Bids must include the NFCC computation pursuant to Section 23.4.1.4 of the 2016 revised IRR of RA No. 9184, which must be sufficient for the total of the ABCs for all the lots or items participated in by the prospective Bidder. For bidders submitting the committed Line of Credit, it must be at least equal to ten percent (10%) of the ABCs for all the lots or items participated in by the prospective Bidder.



20. Post-Qualification

- 20.1. *[Include if Framework Agreement will be used:]* For multi-year Framework Agreement, all bidders initially determined to be eligible and financially compliant shall be subject to initial post-qualification. The BAC shall then recommend the execution of a Framework Agreement among all eligible, technically and financially compliant bidders and the Procuring Entity and shall be issued by HoPE a Notice to Execute Framework Agreement. The determination of the Lowest Calculated Bid (LCB) shall not be performed by the BAC until a Mini-Competition is conducted among the bidders who executed a Framework Agreement. When a Call for Mini-Competition is made, the BAC shall allow the bidders to submit their best financial proposals on such pre-scheduled date, time and place to determine the bidder with the LCB.
- 20.2. Within a non-extendible period of five (5) calendar days from receipt by the Bidder of the notice from the BAC that it submitted the Lowest Calculated Bid, the Bidder shall submit its latest income and business tax returns filed and paid through the BIR Electronic Filing and Payment System (eFPS) and other appropriate licenses and permits required by law and stated in the BDS.

21. Signing of the Contract

- 21.1. The documents required in Section 37.2 of the 2016 revised IRR of RA No. 9184 shall form part of the Contract. Additional Contract documents are indicated in the **BDS**.



Section III. Bid Data Sheet



Bid Data Sheet

ITB Clause								
5.3	<p>For this purpose, contracts similar to the Project shall be:</p> <ol style="list-style-type: none"> a. Supply, delivery and installation of modular office systems and furniture b. Completed within five (5) years prior to the deadline for the submission and opening of bids 							
7.1	Subcontracting is not allowed							
12	The price of the Goods shall be quoted DDP delivered at <i>2nd Floor and 7th Floor, SSS Main Building, East Avenue, Diliman, Quezon City.</i>							
14.1	<p>The bid security shall be in the form of a Bid Securing Declaration, or any of the following forms and amounts:</p> <table border="1" style="margin-left: auto; margin-right: auto; border-collapse: collapse;"> <thead> <tr> <th style="width: 60%; text-align: center;">Form of Bid Security</th> <th style="width: 40%; text-align: center;">Amount of Bid Security (Not less than the Percentage of the ABC)</th> </tr> </thead> <tbody> <tr> <td style="padding: 5px;">Cash or cashier's/manager's check issued by a Universal or Commercial Bank.</td> <td rowspan="2" style="text-align: center; vertical-align: middle;"> Two percent (2%) or Php 53,392.77 </td> </tr> <tr> <td style="padding: 5px;">Bank draft/guarantee or irrevocable letter of credit issued by a Universal or Commercial Bank: Provided, however, that it shall be confirmed or authenticated by a Universal or Commercial Bank, if issued by a foreign bank.</td> </tr> <tr> <td style="padding: 5px;">Surety bond callable upon demand issued by a surety or insurance company duly certified by the Insurance Commission as authorized to issue such security.</td> <td style="text-align: center; vertical-align: middle;"> Five percent (5%) or Php 133,481.94 </td> </tr> </tbody> </table> <p style="margin-left: 40px;">*Bank issued securities must be issued by a universal/commercial bank.</p> <p style="margin-left: 40px;">*Surety Bonds must be accompanied by a certification from Insurance Commission that issuer is authorized to issue such security.</p> <p style="margin-left: 40px;">* Bid Securing Declaration must be notarized by a duly commissioned Notary Public.</p>	Form of Bid Security	Amount of Bid Security (Not less than the Percentage of the ABC)	Cash or cashier's/manager's check issued by a Universal or Commercial Bank.	Two percent (2%) or Php 53,392.77	Bank draft/guarantee or irrevocable letter of credit issued by a Universal or Commercial Bank: Provided, however, that it shall be confirmed or authenticated by a Universal or Commercial Bank, if issued by a foreign bank.	Surety bond callable upon demand issued by a surety or insurance company duly certified by the Insurance Commission as authorized to issue such security.	Five percent (5%) or Php 133,481.94
Form of Bid Security	Amount of Bid Security (Not less than the Percentage of the ABC)							
Cash or cashier's/manager's check issued by a Universal or Commercial Bank.	Two percent (2%) or Php 53,392.77							
Bank draft/guarantee or irrevocable letter of credit issued by a Universal or Commercial Bank: Provided, however, that it shall be confirmed or authenticated by a Universal or Commercial Bank, if issued by a foreign bank.								
Surety bond callable upon demand issued by a surety or insurance company duly certified by the Insurance Commission as authorized to issue such security.	Five percent (5%) or Php 133,481.94							
19.3	<p>The ABC is ₱2,669,638.72.</p> <p>Any bid with a financial component exceeding this amount shall not be accepted.</p>							
20.1	Not Applicable							



20.2	<p>The Lowest Calculated Bidder shall submit the following:</p> <ol style="list-style-type: none"> 1. Registration certificate from Securities and Exchange Commission (SEC) for corporation including Articles of Incorporation and General Information Sheet (GIS) for corporation or Department of Trade and Industry (DTI) for sole proprietorship, or Cooperative Development Authority (CDA) for cooperatives or its equivalent document 2. Mayor's or Business permit issued by the city or municipality where the principal place of business of the prospective bidder is located, or the equivalent document for Exclusive Economic Zones or Areas; 3. Tax clearance per E.O. No. 398, s. 2005, as finally reviewed and approved by the Bureau of Internal Revenue (BIR) 4. Latest Audited Financial Statements 5. Latest income tax return corresponding to the Audited Financial Statements submitted, filed electronically (EFPS); 6. Quarterly VAT (business tax returns) per Revenue Regulations 3-2005 for April 2021 to September 2021 filed electronically (EFPS);
21.1	Not Applicable



Section IV. General Conditions of Contract



1. Scope of Contract

This Contract shall include all such items, although not specifically mentioned, that can be reasonably inferred as being required for its completion as if such items were expressly mentioned herein. All the provisions of RA No. 9184 and its 2016 revised IRR, including the Generic Procurement Manual, and associated issuances, constitute the primary source for the terms and conditions of the Contract, and thus, applicable in contract implementation. Herein clauses shall serve as the secondary source for the terms and conditions of the Contract.

This is without prejudice to Sections 74.1 and 74.2 of the 2016 revised IRR of RA No. 9184 allowing the GPPB to amend the IRR, which shall be applied to all procurement activities, the advertisement, posting, or invitation of which were issued after the effectivity of the said amendment.

Additional requirements for the completion of this Contract shall be provided in the **Special Conditions of Contract (SCC)**.

2. Advance Payment and Terms of Payment

2.1. Advance payment of the contract amount is provided under Annex “D” of the revised 2016 IRR of RA No. 9184.

2.2. The Procuring Entity is allowed to determine the terms of payment on the partial or staggered delivery of the Goods procured, provided such partial payment shall correspond to the value of the goods delivered and accepted in accordance with prevailing accounting and auditing rules and regulations. The terms of payment are indicated in the **SCC**.

3. Performance Security

Within ten (10) calendar days from receipt of the Notice of Award by the Bidder from the Procuring Entity but in no case later than the signing of the Contract by both parties, the successful Bidder shall furnish the performance security in any of the forms prescribed in Section 39 of the 2016 revised IRR of RA No. 9184.

4. Inspection and Tests

The Procuring Entity or its representative shall have the right to inspect and/or to test the Goods to confirm their conformity to the Project specifications at no extra cost to the Procuring Entity in accordance with the Generic Procurement Manual. In addition to tests in the **SCC, Section VII (Technical Specifications)** shall specify what inspections and/or tests the Procuring Entity requires, and where they are to be conducted. The Procuring Entity shall notify the Supplier in writing, in a timely manner, of the identity of any representatives retained for these purposes.

All reasonable facilities and assistance for the inspection and testing of Goods, including access to drawings and production data, shall be provided by the Supplier to the authorized inspectors at no charge to the Procuring Entity.

5. Warranty

5.1 In order to assure that manufacturing defects shall be corrected by the Supplier, a warranty shall be required from the Supplier as provided under Section 62.1 of the 2016 revised IRR of RA No. 9184.



5.2 The Procuring Entity shall promptly notify the Supplier in writing of any claims arising under this warranty. Upon receipt of such notice, the Supplier shall, repair or replace the defective Goods or parts thereof without cost to the Procuring Entity, pursuant to the Generic Procurement Manual.

6. Liability of the Supplier

The Supplier's liability under this Contract shall be as provided by the laws of the Republic of the Philippines.

If the Supplier is a joint venture, all partners to the joint venture shall be jointly and severally liable to the Procuring Entity.



Section V. Special Conditions of Contract



Special Conditions of Contract

GCC Clause	
1	<p>Delivery and Documents –</p> <p>For purposes of the Contract, “EXW,” “FOB,” “FCA,” “CIF,” “CIP,” “DDP” and other trade terms used to describe the obligations of the parties shall have the meanings assigned to them by the current edition of INCOTERMS published by the International Chamber of Commerce, Paris. The Delivery terms of this Contract shall be as follows:</p> <p>The delivery terms applicable to the Contract are DDP delivered at 2nd Floor and 7th Floor, SSS Main Building, East Avenue, Diliman, Quezon City. In accordance with INCOTERMS.</p> <p>The delivery terms applicable to this Contract are delivered to 2nd Floor and 7th Floor Social Security System, East Avenue, Diliman, Quezon City. Risk and title will pass from the Supplier to the Procuring Entity upon receipt and final acceptance of the Goods at their final destination.</p> <p>Delivery of the Goods shall be made by the Supplier in accordance with the terms specified in Section VI (Schedule of Requirements).</p> <p>For purposes of this Clause the Procuring Entity’s Representative at the Project Site is Engr. Gilbert N. Magalit, Department Manager III – Engineering and Facilities Management Department, or his duly authorized representative.</p> <p>Incidental Services –</p> <p>The Supplier is required to provide all of the following services, including additional services, if any, specified in Section VI. Schedule of Requirements:</p> <ol style="list-style-type: none"> a. performance or supervision of on-site assembly and/or start-up of the supplied Goods; b. furnishing of tools required for assembly and/or maintenance of the supplied Goods; c. furnishing of a detailed operations and maintenance manual for each appropriate unit of the supplied Goods; d. performance or supervision or maintenance and/or repair of the supplied Goods, for a period of time agreed by the parties, provided that this service shall not relieve the Supplier of any warranty obligations under this Contract; <p>The Contract price for the Goods shall include the prices charged by the Supplier for incidental services and shall not exceed the prevailing rates charged to other parties by the Supplier for similar services.</p> <p>Spare Parts –</p> <p>The Supplier is required to provide all of the following materials, notifications, and information pertaining to spare parts manufactured or distributed by the Supplier:</p> <ol style="list-style-type: none"> 1. such spare parts as the Procuring Entity may elect to purchase from the Supplier, provided that this election shall not relieve the Supplier of any warranty obligations under this Contract; and 2. in the event of termination of production of the spare parts:



- i. advance notification to the Procuring Entity of the pending termination, in sufficient time to permit the Procuring Entity to procure needed requirements; and
- ii. following such termination, furnishing at no cost to the Procuring Entity, the blueprints, drawings, and specifications of the spare parts, if requested.

The Supplier shall carry sufficient inventories to assure ex-stock supply of consumable spare parts or components for the Goods for a period of sixty (60) calendar days and within applicable warranty period.

Spare parts or components shall be supplied as promptly as possible, but in any case, within two (2) months of placing the order.

Packaging –

The Supplier shall provide such packaging of the Goods as is required to prevent their damage or deterioration during transit to their final destination, as indicated in this Contract. The packaging shall be sufficient to withstand, without limitation, rough handling during transit and exposure to extreme temperatures, salt and precipitation during transit, and open storage. Packaging case size and weights shall take into consideration, where appropriate, the remoteness of the Goods’ final destination and the absence of heavy handling facilities at all points in transit.

The packaging, marking, and documentation within and outside the packages shall comply strictly with such special requirements as shall be expressly provided for in the Contract, including additional requirements, if any, specified below, and in any subsequent instructions ordered by the Procuring Entity.

The outer packaging must be clearly marked on at least four (4) sides as follows:

- Name of the Procuring Entity
- Name of the Supplier
- Contract Description
- Final Destination
- Gross weight
- Any special lifting instructions
- Any special handling instructions
- Any relevant HAZCHEM classifications

A packaging list identifying the contents and quantities of the package is to be placed on an accessible point of the outer packaging if practical. If not practical the packaging list is to be placed inside the outer packaging but outside the secondary packaging.

Transportation –

Where the Supplier is required under Contract to deliver the Goods CIF, CIP, or DDP, transport of the Goods to the port of destination or such other named place of destination in the Philippines, as shall be specified in this Contract, shall be arranged and paid for by the Supplier, and the cost thereof shall be included in the Contract Price.

Where the Supplier is required under this Contract to transport the Goods to a specified place of destination within the Philippines, defined as the Project Site, transport to such place of destination in the Philippines, including insurance and storage, as shall be specified in this Contract, shall be arranged by the Supplier, and related costs shall be included in the contract price.



	<p>Where the Supplier is required under Contract to deliver the Goods CIF, CIP or DDP, Goods are to be transported on carriers of Philippine registry. In the event that no carrier of Philippine registry is available, Goods may be shipped by a carrier which is not of Philippine registry provided that the Supplier obtains and presents to the Procuring Entity certification to this effect from the nearest Philippine consulate to the port of dispatch. In the event that carriers of Philippine registry are available but their schedule delays the Supplier in its performance of this Contract the period from when the Goods were first ready for shipment and the actual date of shipment the period of delay will be considered force majeure.</p> <p>The Procuring Entity accepts no liability for the damage of Goods during transit other than those prescribed by INCOTERMS for DDP deliveries. In the case of Goods supplied from within the Philippines or supplied by domestic Suppliers risk and title will not be deemed to have passed to the Procuring Entity until their receipt and final acceptance at the final destination.</p> <p>Intellectual Property Rights –</p> <p>The Supplier shall indemnify the Procuring Entity against all third-party claims of infringement of patent, trademark, or industrial design rights arising from use of the Goods or any part thereof.</p>
2.2	<p>One-time payment after final acceptance which shall be credited to the LANDBANK or DBP account of the service provider.</p> <p>The payment shall be subject to retention of Withholding Tax and other applicable taxes in accordance with existing Laws and BIR Rules and Regulations, to be remitted directly to the BIR by the SSS.</p> <p>Payment using Letter of Credit is not allowed.</p>
4	<p>The inspections and tests that will be conducted are:</p> <p>A. During the post qualification, the LCB is required to submit:</p> <p>Actual materials to be used (as indicated in the Technical Specifications)</p> <p>Modular Office System:</p> <p>i. Fabric Swatches</p> <p>ii. Laminates</p> <p>Seating Furniture:</p> <p>i. Gas lift mechanism (Stabilus)</p> <p>ii. Prong Bases</p> <p>iii. Molded foam (Uratex or approved equal)</p> <p>iv. Leatherette and fabric swatches</p> <p>B. Prior to delivery of furniture, the supplier must submit to the SSS Representative mock-up sample within 7 calendar days from the receipt of Notice To Proceed (NTP), for inspection and approval if in accordance with the specifications.</p>



5.1	<p>Warranty Period for the modular office systems and furniture shall be the following:</p> <table border="1" data-bbox="389 244 1425 667"> <thead> <tr> <th data-bbox="389 244 1088 299">Items</th> <th data-bbox="1088 244 1425 299">Warranty Period</th> </tr> </thead> <tbody> <tr> <td data-bbox="389 299 1088 468">Modular Office Systems (workstations, panel components, upholstery, worktop and other accessories, free-standing table, accessories and conference table)</td> <td data-bbox="1088 299 1425 468" rowspan="3">5 years</td> </tr> <tr> <td data-bbox="389 468 1088 518">Contract Furniture (back cabinet)</td> </tr> <tr> <td data-bbox="389 518 1088 573">Steel Shelves, Cabinets and Drawers</td> </tr> <tr> <td data-bbox="389 573 1088 667">Seating Furniture (office chair, upholstery and parts)</td> <td data-bbox="1088 573 1425 667">3 years</td> </tr> </tbody> </table> <p>The supplier warrants that the required furniture supplied, delivered and installed are new, unused and comply with the technical specifications provided. It also warrants that all supplied furniture shall have no defects arising from poor quality of materials or workmanship. Warranty does not cover damages due to accidental causes by the end user or by any natural causes/force majeure.</p>	Items	Warranty Period	Modular Office Systems (workstations, panel components, upholstery, worktop and other accessories, free-standing table, accessories and conference table)	5 years	Contract Furniture (back cabinet)	Steel Shelves, Cabinets and Drawers	Seating Furniture (office chair, upholstery and parts)	3 years
Items	Warranty Period								
Modular Office Systems (workstations, panel components, upholstery, worktop and other accessories, free-standing table, accessories and conference table)	5 years								
Contract Furniture (back cabinet)									
Steel Shelves, Cabinets and Drawers									
Seating Furniture (office chair, upholstery and parts)	3 years								
5.2	<p>Should the Supplier opts to issue a warranty in the form of Special Bank Guarantee, said guarantee should be renewable annually or every two (2) years until the end of warranty period stated above.</p>								
6	<p>Liability of Supplier</p> <ol style="list-style-type: none"> 1. CONFIDENTIALITY. Neither party shall, without the prior written consent of the other, disclose or make available to any person, make public, or use directly or indirectly, except for the performance and implementation of the works, any confidential information, acquired from an information holder in connection with the performance of this Contract, unless: (i) the information is known to the disclosing party, as evidenced by its written records, prior to obtaining the same from the information holder and is not otherwise subject to disclosure restrictions on the disclosing party, (ii) the information is disclosed to the disclosing party by a third party who did not receive the same, directly or indirectly, from an information holder, and who has no obligation of secrecy with respect thereto, or (iii) required to be disclosed by law. <p>The obligation of confidentiality by both parties, as provided herein, shall survive the termination of the Agreement.</p> 2. MERGER AND CONSOLIDATION. In case of merger, consolidation or change of ownership of the SUPPLIER with other company, it is the responsibility of the surviving company/consolidated company/acquiring entity to inform SSS of the change in corporate structure/ownership. Failure to do so shall translate in such company assuming all liabilities of the acquired/merged company under the Agreement. 3. FORCE MAJEURE. SUPPLIER shall not be liable for forfeiture of its performance security, liquidated damages, or termination for default if and to the extent that SUPPLIER's delay in performance or other failure to perform its obligations under this Agreement is the result of a force majeure. <p>For purposes of this Agreement the terms "force majeure" and "fortuitous event" may be used interchangeably. In this regard, a fortuitous event or force majeure shall be interpreted to mean an event which SUPPLIER could not have foreseen, or which though foreseen, was inevitable. It shall not include ordinary unfavorable weather conditions; and any other cause the effects of which could have been</p> 								



avoided with the exercise of reasonable diligence by SUPPLIER. Such events may include, but not limited to, acts of SSS in its sovereign capacity, wars or revolutions, fires, floods, epidemics, quarantine restrictions, and freight embargoes.

If a force majeure situation arises, SUPPLIER shall promptly notify SSS in writing of such condition and the cause thereof. Unless otherwise directed by SSS in writing, SUPPLIER shall continue to perform its obligations under this Agreement as far as is reasonably practical and shall seek all reasonable alternative means for performance not prevented by the force majeure.

4. **NON-ASSIGNMENT.** SUPPLIER shall not assign its rights or obligations under this Agreement, in whole or in part, except with SSS's prior written consent. SUPPLIER shall not subcontract in whole or in part the PROJECT and deliverables subject of this Agreement without the written consent of SSS.
5. **WAIVER.** Failure by either party to insist upon the other strict performance of any of the terms and conditions hereof shall not be deemed a relinquishment or waiver of any subsequent breach or default of the terms and conditions hereof, which can only be deemed made if expressed in writing and signed by its duly authorized representative. No such waiver shall be construed as modification of any of the provisions of the Agreement or as a waiver of any past or future default or breach hereof, except as expressly stated in such waiver.
6. **CUMULATIVE REMEDIES.** Any and all remedies granted to the parties under the applicable laws and the Contract shall be deemed cumulative and may therefore, at the sole option and discretion, be availed of by the aggrieved party simultaneously, successively, or independently.
7. **NO EMPLOYER-EMPLOYEE RELATIONSHIP.** It is expressly and manifestly understood and agreed upon that the employees of SUPPLIER assigned to perform the PROJECT are not employees of SSS. Neither is there an employer-employee relationship between SSS and SUPPLIER.

The Agreement does not create an employer-employee relationship between SSS and the SUPPLIER including its personnel; that the services rendered by the personnel assigned by SUPPLIER to SSS in the performance of its obligation under the contract do not represent government service and will not be credited as such; that its personnel assigned to SSS are not entitled to benefits enjoyed by SSS' officials and employees such as Personal Economic Relief Allowance (PERA), Representation and Transportation Allowance (RATA), ACA, etc.; that these personnel are not related within the third degree of consanguinity or affinity to the contracting officer and appointing authority of SSS; that they have not been previously dismissed from the government service by reason of an administrative case; that they have not reached the compulsory retirement age of sixty-five (65); and that they possess the education, experience and skills required to perform the job. The SUPPLIER hereby acknowledges that no authority has been given by SSS to hire any person as an employee of the latter. Any instruction given by SSS or any of its personnel to SUPPLIER's employees are to be construed merely as a measure taken by the former to ensure and enhance the quality of project performed hereunder. The SUPPLIER shall, at all times, exercise supervision and control over its employees in the performance of its obligations under the contract.

8. **PARTNERSHIP.** Nothing in the contract shall constitute a partnership between the parties. No party or its agents or employees shall be deemed to be the agent, employee or representative of any other party.

9. **COMPLIANCE WITH SS LAW.** SUPPLIER shall report all its employees to SSS for coverage and their contributions, as well as, all amortizations for salary/education/calamity and other SSS loans shall be updated. Should SUPPLIER fail to comply with its obligations under the provisions of the SS Law and Employees' Compensation Act, SSS shall have the authority to deduct any unpaid SS and EC contributions, salary, educational, emergency and/or calamity loan amortizations, employer's liability for damages, including interests and penalties from SUPPLIER's receivables under this Agreement.

Further, prescription does not run against SSS for its failure to demand SS contributions or payments from SUPPLIER. Moreover, SUPPLIER shall forever hold in trust SS contributions or payments of its employees until the same is fully remitted to SSS.

10. **COMPLIANCE WITH LABOR LAWS.** SUPPLIER, as employer of the personnel assigned to undertake the PROJECT, shall comply with all its obligations under existing laws and their implementing rules and regulations on the payment of minimum wage, overtime pay, and other labor-related benefits as well as remittances or payment of the appropriate amount or contributions/payment (SSS, EC, Pag-IBIG, PhilHealth and taxes) with concerned government agencies/offices.

It is agreed further, that prior to the release of any payment by SSS to SUPPLIER, its President or its duly authorized representative, shall submit a sworn statement that all monies due to all its employees assigned to the PROJECT as well as benefits by law and other related labor legislation have been paid by SUPPLIER and that he/she assumed full responsibility thereof.

11. **COMPLIANCE WITH TAX LAWS.** SUPPLIER shall, in compliance with tax laws, pay the applicable taxes in full and on time and shall regularly present to SSS within the duration of the Contract, tax clearance from the Bureau of Internal Revenue (BIR) as well as copy of its income and business tax returns duly stamped by the BIR and duly validated with the tax payments made thereon. Failure by SUPPLIER to comply with the foregoing shall entitle SSS to suspend payment of the Contract Price.

As required under Executive Order (EO) 398, s. 2005, SUPPLIER shall submit income and business tax returns duly stamped and received by the BIR, before entering and during the duration of this Agreement. SUPPLIER, through its responsible officer, shall also certify under oath that it is free and clear of all tax liabilities to the government. SUPPLIER shall pay taxes in full and on time and that failure to do so will entitle SSS to suspend or terminate this Agreement.

12. **LIQUIDATED DAMAGES.** If SUPPLIER fails to satisfactorily deliver any or all of the Goods and/or to perform the Services within the period(s) specified in the PBD inclusive of duly granted time extensions if any, SSS shall, without prejudice to its other remedies under this Agreement and under the applicable law, deduct from the Contract Price, as liquidated damages, the applicable rate of one tenth (1/10) of one (1) percent of the cost of the unperformed portion for every day of delay until actual delivery or performance. Once the amount of liquidated damages reaches ten percent (10%), SSS may rescind or terminate this Agreement, without prejudice to other courses of action and remedies open to it.

13. **HOLD FREE and HARMLESS.** SUPPLIER agrees to defend, indemnify, and hold SSS free and harmless from any and all claims, damages, expenses, fines, penalties and/or liabilities of whatever nature and kind, whether in law or equity, that may arise by reason of the implementation of the Agreement. In addition, SUPPLIER agrees to indemnify SSS for any damage as a result of said implementation.

SUPPLIER hereby assumes full responsibility for any injury, including death, loss or damage which may be caused to SSS' employees or property or third person due to SUPPLIER's employees' fault or negligence, and further binds itself to hold SSS free and harmless from any of such injury or damage. SSS shall not be responsible for any injury, loss or damage which SUPPLIER or any of its employees may sustain in the performance of SUPPLIER's obligations under this Agreement.

14. **SETTLEMENT OF DISPUTES.** If any dispute or difference of any kind whatsoever shall arise between SSS and SUPPLIER in connection with or arising out of this Agreement, the Parties shall make every effort to resolve amicably such dispute or difference by mutual consultation.

If after thirty (30) days, the Parties have failed to resolve their dispute or difference by such mutual consultation, then either SSS or SUPPLIER may give notice to the other Party of its intention to commence arbitration, in accordance with RA No. 876, otherwise known as the "Arbitration Law" and RA No. 9285, otherwise known as the "Alternative Dispute Resolution Act of 2004," in order to settle their disputes.

No arbitration in respect of this matter may be commenced unless such notice is given.

Notwithstanding any reference to arbitration herein, the Parties shall continue to perform their respective obligations under this Agreement unless they otherwise agree.

15. **VENUE OF ACTIONS.** In the event court action is necessary in order to promote Arbitration, such action shall be filed only before the proper courts of Quezon City, to the exclusion of all other venues.

16. **GOVERNING LAW.** The Agreement shall be governed by and interpreted according to the laws of the Republic of the Philippines.

17. **AMENDMENTS.** This Agreement may be amended only in writing and executed by the parties or their duly authorized representatives.

18. **SEPARABILITY.** If any one or more of the provisions contained in the contract or any document executed in connection herewith shall be invalid, illegal or unenforceable in any respect under any applicable law, then: (i) the validity, legality and enforceability of the remaining provisions contained herein or therein shall not in any way be affected or impaired and shall remain in full force and effect; and (ii) the invalid, illegal or unenforceable provision shall be replaced by the parties immediately with a term or provision that is valid, legal and enforceable and that comes closest to expressing the intention of such invalid illegal or unenforceable term of provision.

19. **BINDING EFFECT.** The Agreement shall be binding upon the Parties hereto, their assignee/s and successor/s-in-interest.



Section VI. Schedule of Requirements

The delivery schedule expressed as weeks/months stipulates hereafter a delivery date which is the date of delivery to the project site.

Item No.	Description	Delivered, Weeks/Months
I.	Supply, Delivery and Installation of Modular Furniture for CCD, MAD and OVP PASED	All items in the Contract shall be delivered and/or installed within sixty (60) calendar days upon the receipt of Notice to Proceed (NTP) and Purchase Order (PO).
II	Warranty	To commence upon issuance of final acceptance from EFMD.



Section VII. Technical Specifications



Technical Specifications

Item	Specifications	Statement of Compliance
<p>Bidders must state here either “Comply” or “Not Comply” against each of the individual parameters of each Specification stating the corresponding performance parameter of the equipment offered. Statements of “Comply” or “Not Comply” must be supported by evidence in a Bidders Bid and cross-referenced to that evidence. Evidence shall be in the form of manufacturer’s un-amended sales literature, unconditional statements of specification and compliance issued by the manufacturer, samples, independent test data etc., as appropriate. A statement that is not supported by evidence or is subsequently found to be contradicted by the evidence presented will render the Bid under evaluation liable for rejection. A statement either in the Bidder's statement of compliance or the supporting evidence that is found to be false either during Bid evaluation, post-qualification or the execution of the Contract may be regarded as fraudulent and render the Bidder or supplier liable for prosecution subject to the applicable laws and issuances.</p>		
1.0	Supply, delivery and installation of Modular Office Systems and Furniture (See attached Annex 1 "Photos" and Annex 2 "Plans/Drawings")	
I.	MODULAR OFFICE SYSTEM	
A	Division Head Workstation - 1 set	
1pc	<p>D-shaped Free-Standing Executive Table Worktop: 2000mm L x 750mm D x 740mm H in 30mm thk MDF board tabletop in HPL finish w/ 2mm thk PVC edging and two (2) plastic grommet with rotating cover</p> <p>Modesty Panel: 25mm thk MDF board gable ends and modesty panel & Side Support in HPL finish w/ 2mm thk PVC edging</p> <p>Legs/Support: 30mm thick MDF board in high pressure laminate (HPL) finish with 2 mm thick PVC edging and adjustable PVC gliders.</p>	
1pc	<p>Side Return Table, 1000mm L x 450mm D x 740mm H x 30mm thk MDF board tabletop in HPL finish with 2 mm thick PVC edging and PVC gliders</p> <p>Modesty Panel: 25mm thick MDF board in high pressure laminate (HPL) finish with 2 mm thick PVC edging</p> <p>Legs/Support: 25 mm thick MDF board in high pressure laminate (HPL) finish with 2 mm thick PVC edging and PVC gliders</p>	
Accessories		
1pc	Center Drawer, 540mm W x 400mm D x 95mm H Gauge 22 cold rolled steel in powder coated finish and full extension ball-bearing slides; Color: black	
1pc	Keyboard Tray, Hard Plastic with full extension ball-bearing slides; Color: Black	
<p>Color/Finishes: Specific Color/finishes subject for approval High Pressure Laminate Finish: Formica or WilsonArt Laminates Tabletop: Lincoln Walnut code “7188” Legs/Supports : Black code “0909”</p>		



Item	Specifications		Statement of Compliance
B	Department Manager Workstation - 2 sets		
	2 pcs	<p>D-shaped Free-Standing Executive Table Worktop: 2000mm L x 750mm D x 740mm H in 30mm thk MDF board tabletop in HPL finish w/ 2mm thk PVC edging and two (2) plastic grommet with rotating cover</p> <p>Modesty Panel: 25mm thk MDF board gable ends and modesty panel & Side Support in HPL finish w/ 2mm thk PVC edging</p> <p>Legs/Support: 30mm thick MDF board in high pressure laminate (HPL) finish with 2 mm thick PVC edging and adjustable PVC gliders.</p>	
	2 pcs	<p>Side Return Table, 1000mm L x 450mm D x 740mm H x 30mm thk MDF board tabletop in HPL finish with 2 mm thick PVC edging and PVC gliders Modesty Panel: 25mm thick MDF board in high pressure laminate (HPL) finish with 2 mm thick PVC edging Legs/Support: 25 mm thick MDF board in high pressure laminate (HPL) finish with 2 mm thick PVC edging and PVC gliders</p>	
	Accessories		
	2 pcs	Center Drawer, 540mm W x 400mm D x 95mm H Gauge 22 cold rolled steel in powder coated finish and full extension ball-bearing slides; Color: black	
	2 pcs	Keyboard Tray, Hard Plastic with full extension ball-bearing slides; Color: Black	
	Color/Finishes: Specific Color/finishes subject for approval High Pressure Laminate Finish: Formica or WilsonArt Laminates Tabletop: Lincoln Walnut code "7188" Legs/Supports : Black code "0909"		
	1-Seater Section Head Workstation - 4 sets <i>L-shaped workstation with 50mm thick Modular Panel in cushioned fabric upholstery with 30mm thk Medium Density Fiber (MDF) board tabletop in High Pressure Laminate (HPL) finish, w/ Skirting/Base 100mm (H) powder-coated aluminum panel with raceway for cables and three (3) knockouts for UPS / Normal Power / Datacom outlets</i>		
	1. Modular Panels		
	4pcs	Fabric Screen Panel, Two-Tone, 1000mm W x 1200mm H x 50mm thk	
	4pcs	Fabric Screen Panel, Two-Tone, 600mm W x 1200mm H x 50mm thk	
	4pcs	Fabric Screen Panel, Two-Tone, 450mm W x 1200mm H x 50mm thk	
	4pcs	Fabric Screen Panel, Two-Tone, 1500mm W x 900mm H x 50mm thk	
	4pcs	Fabric Screen Panel, Two-Tone, 600mm W x 900mm H x 50mm thk	
	8pcs	Aluminum Corner Post, 2-way 1200mm H	
	4pcs	Aluminum Corner Post, 2-way 900mm H	
	4pcs	Aluminum End Trim, 1200mm H	
	4pcs	Aluminum End Trim, 900mm H	
	4pcs	Aluminum End Trim, 300mm H	
	2. Worktop		
	4pcs	Rectangular Work Top, 1500mm L x 600mm D x 30mm thk MDF board in HPL finish with 2mm thick PVC edging and	



Item	Specifications	Statement of Compliance
	two (2) plastic grommet with rotating cover for every work surfaces.	
4pcs	Rectangular Work Top, 1000mm L x 450mm D x 30mm thk MDF board in HPL finish with 2mm thick PVC edging and two (1) plastic grommet with rotating cover for every work surfaces.	
3. Accessories		
4pcs	Center Drawer, 540mm W x 400mm D x 95mm H	
4pcs	Keyboard Tray, Hard Plastic	
<p>Color/Finishes: Specific Color/finishes subject for approval Modular panel Fabric Upholstery: Two-tone, Titch brand fabric or approved equal. Top: Titch “Sunrise”; Bottom: Titch “Expensive Blue”</p> <p>High Pressure Laminate Finish: Formica or WilsonArt Laminates Tabletop: Folkstone “0927”</p> <p>Aluminum Extrusions: Powder coated finish. Submit sample for approval</p>		
D	<p>2-Seater Section Head Workstation - 1 set</p> <p><i>L-shaped workstation with 50mm thick Modular Panel in cushioned fabric upholstery with 30mm thk Medium Density Fiber (MDF) board tabletop in High Pressure Laminate (HPL) finish, w/ Skirting/Base 100mm (H) powder-coated aluminum panel with raceway for cables and three (3) knockouts for UPS / Normal Power / Datacom outlets</i></p>	
1. Modular Panels		
1pc	Fabric Screen Panel, Two-Tone, 1500mm W x 1200mm H x 50mm thk	
1pc	Fabric Screen Panel, Two-Tone, 1100mm W x 1200mm H x 50mm thk	
1pc	Fabric Screen Panel, Two-Tone, 1050mm W x 1200mm H x 50mm thk	
2pcs	Fabric Screen Panel, Two-Tone, 1000mm W x 1200mm H x 50mm thk	
4pcs	Fabric Screen Panel, Two-Tone, 600mm W x 1200mm H x 50mm thk	
2pcs	Fabric Screen Panel, Two-Tone, 450mm W x 1200mm H x 50mm thk	
1pc	Aluminum Corner Post, 3-way 1200mm H	
4pcs	Aluminum Corner Post, 2-way 1200mm H	
3pcs	Aluminum End Trim, 1200mm H	
2. Worktop		
2pcs	Rectangular Work Top, 1500mm L x 600mm D x 30mm thk MDF board in HPL finish with 2mm thick PVC edging and two (2) plastic grommet with rotating cover for every work surfaces.	
2pcs	Rectangular Work Top, 1000mm L x 450mm D x 30mm thk MDF board in HPL finish with 2mm thick PVC edging and two (1) plastic grommet with rotating cover for every work surfaces.	
3. Accessories		
2pcs	Center Drawer, 540mm W x 400mm D x 95mm H	
2pcs	Keyboard Tray, Hard Plastic	



Item	Specifications	Statement of Compliance														
	<p>Color/Finishes: Specific Color/finishes subject for approval Modular panel Fabric Upholstery: Two-tone, Titch brand fabric or approved equal. Top: Titch “Sunrise”; Bottom: Titch “Expensive Blue”</p> <p>High Pressure Laminate Finish: Formica or WilsonArt Laminates Tabletop: Folkstone “0927”</p> <p>Aluminum Extrusions: Powder coated finish. Submit sample for approval</p>															
E	<p>1-Seater Staff/Nonsupervisor's Workstation 1 - 1 set</p> <p><i>Modular workstation with 50 mm thick modular panels in cushioned fabric upholstery with 30mm thick MDF board tabletop in High Pressure Laminate finish, , w/ Skirting/Base 100mm (H) powder-coated aluminum panel with raceway for cables and three (3) knockouts for UPS / Normal Power / Datacom outlets</i></p>															
	<p>1. Modular Panels</p> <table border="1" data-bbox="289 962 1219 1303"> <tr> <td data-bbox="289 962 391 1042">1pc</td> <td data-bbox="391 962 1219 1042">Fabric Screen Panel, Two-Tone, 1500mm W x 900mm H x 50mm thk</td> </tr> <tr> <td data-bbox="289 1042 391 1123">2pcs</td> <td data-bbox="391 1042 1219 1123">Fabric Screen Panel, Two-Tone, 600mm W x 900mm H x 50mm thk</td> </tr> <tr> <td data-bbox="289 1123 391 1163">2pcs</td> <td data-bbox="391 1123 1219 1163">Aluminum Corner Post, 2-way 900mm H</td> </tr> <tr> <td data-bbox="289 1163 391 1204">2pcs</td> <td data-bbox="391 1163 1219 1204">Aluminum End Trim, 900mm H</td> </tr> <tr> <td data-bbox="289 1204 391 1303">1 set</td> <td data-bbox="391 1204 1219 1303">Skirting/Base 100mm (H) powder-coated aluminum panel with raceway for cables and three (3) knockouts for UPS / Normal Power / Datacom outlets.</td> </tr> </table> <p>2. Worktop</p> <table border="1" data-bbox="289 1338 1219 1486"> <tr> <td data-bbox="289 1338 391 1486">1pc</td> <td data-bbox="391 1338 1219 1486">Rectangular Work Top, 1500mm L x 600mm D x 30mm thk MDF board in HPL finish with 2mm thick PVC edging and two (2) plastic grommet with rotating cover for every work surfaces.</td> </tr> </table> <p>3. Accessories</p> <table border="1" data-bbox="289 1526 1219 1567"> <tr> <td data-bbox="289 1526 391 1567">1 pc</td> <td data-bbox="391 1526 1219 1567">Keyboard Tray, Hard Plastic</td> </tr> </table> <p>Color/Finishes: Specific Color/finishes subject for approval Modular panel Fabric Upholstery: Two-tone, Titch brand fabric or approved equal. Top: Titch “Sunrise”; Bottom: Titch “Expensive Blue”</p> <p>High Pressure Laminate Finish: Formica or WilsonArt Laminates Tabletop: Folkstone “0927”</p> <p>Aluminum Extrusions: Powder coated finish. Submit sample for approval</p>	1pc	Fabric Screen Panel, Two-Tone, 1500mm W x 900mm H x 50mm thk	2pcs	Fabric Screen Panel, Two-Tone, 600mm W x 900mm H x 50mm thk	2pcs	Aluminum Corner Post, 2-way 900mm H	2pcs	Aluminum End Trim, 900mm H	1 set	Skirting/Base 100mm (H) powder-coated aluminum panel with raceway for cables and three (3) knockouts for UPS / Normal Power / Datacom outlets.	1pc	Rectangular Work Top, 1500mm L x 600mm D x 30mm thk MDF board in HPL finish with 2mm thick PVC edging and two (2) plastic grommet with rotating cover for every work surfaces.	1 pc	Keyboard Tray, Hard Plastic	
1pc	Fabric Screen Panel, Two-Tone, 1500mm W x 900mm H x 50mm thk															
2pcs	Fabric Screen Panel, Two-Tone, 600mm W x 900mm H x 50mm thk															
2pcs	Aluminum Corner Post, 2-way 900mm H															
2pcs	Aluminum End Trim, 900mm H															
1 set	Skirting/Base 100mm (H) powder-coated aluminum panel with raceway for cables and three (3) knockouts for UPS / Normal Power / Datacom outlets.															
1pc	Rectangular Work Top, 1500mm L x 600mm D x 30mm thk MDF board in HPL finish with 2mm thick PVC edging and two (2) plastic grommet with rotating cover for every work surfaces.															
1 pc	Keyboard Tray, Hard Plastic															
F	<p>1-Seater Staff/Nonsupervisor's Workstation 1 (w/ quarter glass) - 2 sets</p> <p><i>Modular workstation with 50mm thick modular panels in cushioned fabric upholstery with 30mm thick MDF board tabletop in High Pressure Laminate finish, w/ Skirting/Base 100mm (H) powder-coated aluminum panel with raceway for cables and three (3) knockouts for UPS / Normal Power / Datacom outlets</i></p>															
	<p>1. Modular Panels</p> <table border="1" data-bbox="289 2306 1219 2486"> <tr> <td data-bbox="289 2306 391 2386">2pcs</td> <td data-bbox="391 2306 1219 2386">Fabric Screen Panel, Two-Tone, 1500mm W x 1200mm H x 50mm thk</td> </tr> <tr> <td data-bbox="289 2386 391 2454">4pcs</td> <td data-bbox="391 2386 1219 2454">Fabric Screen Panel, Two-Tone, 600mm W x 1200mm H x 50mm thk with quarter glass</td> </tr> <tr> <td data-bbox="289 2454 391 2486">4pcs</td> <td data-bbox="391 2454 1219 2486">Aluminum Corner Post, 2-way 1200mm H</td> </tr> </table>	2pcs	Fabric Screen Panel, Two-Tone, 1500mm W x 1200mm H x 50mm thk	4pcs	Fabric Screen Panel, Two-Tone, 600mm W x 1200mm H x 50mm thk with quarter glass	4pcs	Aluminum Corner Post, 2-way 1200mm H									
2pcs	Fabric Screen Panel, Two-Tone, 1500mm W x 1200mm H x 50mm thk															
4pcs	Fabric Screen Panel, Two-Tone, 600mm W x 1200mm H x 50mm thk with quarter glass															
4pcs	Aluminum Corner Post, 2-way 1200mm H															



Item	Specifications		Statement of Compliance
	4pcs	Aluminum End Trim, 1200mm H	
	2sets	Skirting/Base 100mm (H) powder-coated aluminum panel with raceway for cables and three (3) knockouts for UPS / Normal Power / Datacom outlets.	
	2. Worktop		
	2pcs	Rectangular Work Top, 1500mm L x 600mm D x 30mm thk MDF board in HPL finish with 2mm thick PVC edging and two (2) plastic grommet with rotating cover for every work surfaces.	
	3. Accessories		
	2pcs	Keyboard Tray, Hard Plastic	
	<p>Color/Finishes: Specific Color/finishes subject for approval Modular panel Fabric Upholstery: Two-tone, Titch brand fabric or approved equal. Top: Titch “Sunrise”; Bottom: Titch “Expensive Blue”</p> <p>High Pressure Laminate Finish: Formica or WilsonArt Laminates Tabletop: Folkstone “0927”</p> <p>Aluminum Extrusions: Powder coated finish. Submit sample for approval</p>		
G	<p>2-Seater Staff/Nonsupervisor's Workstation 1 (Back to Back) - 1 set</p> <p><i>Modular workstation with 50mm thick modular panels in cushioned fabric upholstery with 30mm thick MDF board tabletop in High Pressure Laminate finish, w/ Skirting/Base 100mm (H) powder-coated aluminum panel with raceway for cables and three (3) knockouts for UPS / Normal Power / Datacom outlets</i></p>		
	1. Modular Panels		
	1pc	Fabric Screen Panel, Two-Tone, 1500mm W x 1200mm H x 50mm thk	
	4pcs	Fabric Screen Panel, Two-Tone, 600mm W x 1200mm H x 50mm thk with quarter glass	
	2pcs	Aluminum Corner Post, 3-way 1200mm H	
	4pcs	Aluminum End Trim, 1200mm H	
	2. Worktop		
	2pcs	Rectangular Work Top, 1500mm L x 600mm D x 30mm thk MDF board in HPL finish with 2mm thick PVC edging and two (2) plastic grommet with rotating cover for every work surfaces.	
	3. Accessories		
	2pcs	Keyboard Tray, Hard Plastic	
	<p>Color/Finishes: Specific Color/finishes subject for approval Modular panel Fabric Upholstery: Two-tone, Titch brand fabric or approved equal. Top: Titch “Sunrise”; Bottom: Titch “Expensive Blue”</p> <p>High Pressure Laminate Finish: Formica or WilsonArt Laminates Tabletop: Folkstone “0927”</p> <p>Aluminum Extrusions: Powder coated finish. Submit sample for approval</p>		
H	<p>3-Seater Staff/Nonsupervisor's Workstation 1 - 2 sets</p> <p><i>Modular workstation with 50mm thick modular panels in cushioned fabric upholstery with 30mm thick MDF board tabletop in High Pressure Laminate finish, w/ Skirting/Base 100mm (H) powder-coated</i></p>		



Item	Specifications	Statement of Compliance																		
	<i>aluminum panel with raceway for cables and three (3) knockouts for UPS / Normal Power / Datacom outlets</i>																			
	<p>1. Modular Panels</p> <table border="1" data-bbox="297 400 1211 741"> <tr> <td data-bbox="297 400 396 467">2pcs</td> <td data-bbox="396 400 1211 467">Fabric Screen Panel, Two-Tone, 1500mm W x 1200mm H x 50mm thk</td> </tr> <tr> <td data-bbox="297 467 396 537">4pcs</td> <td data-bbox="396 467 1211 537">Fabric Screen Panel, Two-Tone, 1200mm W x 1200mm H x 50mm thk</td> </tr> <tr> <td data-bbox="297 537 396 607">8pcs</td> <td data-bbox="396 537 1211 607">Fabric Screen Panel, Two-Tone, 600mm W x 1200mm H x 50mm thk with quarter glass</td> </tr> <tr> <td data-bbox="297 607 396 650">4pcs</td> <td data-bbox="396 607 1211 650">Aluminum Corner Post, 3-way 1200mm H</td> </tr> <tr> <td data-bbox="297 650 396 693">4pcs</td> <td data-bbox="396 650 1211 693">Aluminum Corner Post, 2-way 1200mm H</td> </tr> <tr> <td data-bbox="297 693 396 741">8pcs</td> <td data-bbox="396 693 1211 741">Aluminum End Trim, 1200mm H</td> </tr> </table> <p>2. Worktop</p> <table border="1" data-bbox="297 755 1211 1069"> <tr> <td data-bbox="297 755 396 919">2pcs</td> <td data-bbox="396 755 1211 919">Rectangular Work Top, 1500mm L x 600mm D x 30mm thk MDF board in HPL finish with 2mm thick PVC edging and two (2) plastic grommet with rotating cover for every work surfaces.</td> </tr> <tr> <td data-bbox="297 919 396 1069">4pcs</td> <td data-bbox="396 919 1211 1069">Rectangular Work Top, 1200mm L x 600mm D x 30mm thk MDF board in HPL finish with 2mm thick PVC edging and two (2) plastic grommet with rotating cover for every work surfaces.</td> </tr> </table> <p>3. Accessories</p> <table border="1" data-bbox="297 1083 1211 1150"> <tr> <td data-bbox="297 1083 396 1150">6pcs</td> <td data-bbox="396 1083 1211 1150">Keyboard Tray, Hard Plastic</td> </tr> </table> <p>Color/Finishes: Specific Color/finishes subject for approval Modular panel Fabric Upholstery: Two-tone, Titch brand fabric or approved equal. Top: Titch “Sunrise”; Bottom: Titch “Expensive Blue”</p> <p>High Pressure Laminate Finish: Formica or WilsonArt Laminates Tabletop: Folkstone “0927”</p> <p>Aluminum Extrusions: Powder coated finish. Submit sample for approval</p>	2pcs	Fabric Screen Panel, Two-Tone, 1500mm W x 1200mm H x 50mm thk	4pcs	Fabric Screen Panel, Two-Tone, 1200mm W x 1200mm H x 50mm thk	8pcs	Fabric Screen Panel, Two-Tone, 600mm W x 1200mm H x 50mm thk with quarter glass	4pcs	Aluminum Corner Post, 3-way 1200mm H	4pcs	Aluminum Corner Post, 2-way 1200mm H	8pcs	Aluminum End Trim, 1200mm H	2pcs	Rectangular Work Top, 1500mm L x 600mm D x 30mm thk MDF board in HPL finish with 2mm thick PVC edging and two (2) plastic grommet with rotating cover for every work surfaces.	4pcs	Rectangular Work Top, 1200mm L x 600mm D x 30mm thk MDF board in HPL finish with 2mm thick PVC edging and two (2) plastic grommet with rotating cover for every work surfaces.	6pcs	Keyboard Tray, Hard Plastic	
2pcs	Fabric Screen Panel, Two-Tone, 1500mm W x 1200mm H x 50mm thk																			
4pcs	Fabric Screen Panel, Two-Tone, 1200mm W x 1200mm H x 50mm thk																			
8pcs	Fabric Screen Panel, Two-Tone, 600mm W x 1200mm H x 50mm thk with quarter glass																			
4pcs	Aluminum Corner Post, 3-way 1200mm H																			
4pcs	Aluminum Corner Post, 2-way 1200mm H																			
8pcs	Aluminum End Trim, 1200mm H																			
2pcs	Rectangular Work Top, 1500mm L x 600mm D x 30mm thk MDF board in HPL finish with 2mm thick PVC edging and two (2) plastic grommet with rotating cover for every work surfaces.																			
4pcs	Rectangular Work Top, 1200mm L x 600mm D x 30mm thk MDF board in HPL finish with 2mm thick PVC edging and two (2) plastic grommet with rotating cover for every work surfaces.																			
6pcs	Keyboard Tray, Hard Plastic																			
I	<p>8-Seater Staff/Nonsupervisor's Workstation 1 - 1 set</p> <p><i>Modular workstation with 50mm thick modular panels in cushioned fabric upholstery with 30mm thick MDF board tabletop in High Pressure Laminate finish, w/ Skirting/Base 100mm (H) powder-coated aluminum panel with raceway for cables and three (3) knockouts for UPS / Normal Power / Datacom outlets</i></p>																			
	<p>1. Modular Panels</p> <table border="1" data-bbox="297 1852 1211 2193"> <tr> <td data-bbox="297 1852 396 1919">1pc</td> <td data-bbox="396 1852 1211 1919">Fabric Screen Panel, Two-Tone, 1500mm W x 1200mm H x 50mm thk</td> </tr> <tr> <td data-bbox="297 1919 396 1989">3pcs</td> <td data-bbox="396 1919 1211 1989">Fabric Screen Panel, Two-Tone, 1200mm W x 1200mm H x 50mm thk</td> </tr> <tr> <td data-bbox="297 1989 396 2059">10pcs</td> <td data-bbox="396 1989 1211 2059">Fabric Screen Panel, Two-Tone, 600mm W x 1200mm H x 50mm thk with quarter glass</td> </tr> <tr> <td data-bbox="297 2059 396 2102">3pcs</td> <td data-bbox="396 2059 1211 2102">Aluminum Corner Post, 4-way 1200mm H</td> </tr> <tr> <td data-bbox="297 2102 396 2145">2pcs</td> <td data-bbox="396 2102 1211 2145">Aluminum Corner Post, 3-way 1200mm H</td> </tr> <tr> <td data-bbox="297 2145 396 2193">10pcs</td> <td data-bbox="396 2145 1211 2193">Aluminum End Trim, 1200mm H</td> </tr> </table> <p>2. Worktop</p> <table border="1" data-bbox="297 2206 1211 2483"> <tr> <td data-bbox="297 2206 396 2370">2pcs</td> <td data-bbox="396 2206 1211 2370">Rectangular Work Top, 1500mm L x 600mm D x 30mm thk MDF board in HPL finish with 2mm thick PVC edging and two (2) plastic grommet with rotating cover for every work surfaces.</td> </tr> <tr> <td data-bbox="297 2370 396 2483">6pcs</td> <td data-bbox="396 2370 1211 2483">Rectangular Work Top, 1200mm L x 600mm D x 30mm thk MDF board in HPL finish with 2mm thick PVC edging and</td> </tr> </table>	1pc	Fabric Screen Panel, Two-Tone, 1500mm W x 1200mm H x 50mm thk	3pcs	Fabric Screen Panel, Two-Tone, 1200mm W x 1200mm H x 50mm thk	10pcs	Fabric Screen Panel, Two-Tone, 600mm W x 1200mm H x 50mm thk with quarter glass	3pcs	Aluminum Corner Post, 4-way 1200mm H	2pcs	Aluminum Corner Post, 3-way 1200mm H	10pcs	Aluminum End Trim, 1200mm H	2pcs	Rectangular Work Top, 1500mm L x 600mm D x 30mm thk MDF board in HPL finish with 2mm thick PVC edging and two (2) plastic grommet with rotating cover for every work surfaces.	6pcs	Rectangular Work Top, 1200mm L x 600mm D x 30mm thk MDF board in HPL finish with 2mm thick PVC edging and			
1pc	Fabric Screen Panel, Two-Tone, 1500mm W x 1200mm H x 50mm thk																			
3pcs	Fabric Screen Panel, Two-Tone, 1200mm W x 1200mm H x 50mm thk																			
10pcs	Fabric Screen Panel, Two-Tone, 600mm W x 1200mm H x 50mm thk with quarter glass																			
3pcs	Aluminum Corner Post, 4-way 1200mm H																			
2pcs	Aluminum Corner Post, 3-way 1200mm H																			
10pcs	Aluminum End Trim, 1200mm H																			
2pcs	Rectangular Work Top, 1500mm L x 600mm D x 30mm thk MDF board in HPL finish with 2mm thick PVC edging and two (2) plastic grommet with rotating cover for every work surfaces.																			
6pcs	Rectangular Work Top, 1200mm L x 600mm D x 30mm thk MDF board in HPL finish with 2mm thick PVC edging and																			



Item	Specifications		Statement of Compliance
		two (2) plastic grommet with rotating cover for every work surfaces.	
	3. Accessories		
	8pcs	Keyboard Tray, Hard Plastic	
	<p>Color/Finishes: Specific Color/finishes subject for approval Modular panel Fabric Upholstery: Two-tone, Titch brand fabric or approved equal. Top: Titch “Sunrise”; Bottom: Titch “Expensive Blue”</p> <p>High Pressure Laminate Finish: Formica or WilsonArt Laminates Tabletop: Folkstone “0927”</p> <p>Aluminum Extrusions: Powder coated finish. Submit sample for approval</p>		
J	<p>3-Seater Staff/Nonsupervisor's Workstation 1a - 1 set (see Annex 1&2)</p> <p><i>Modular workstation with 50mm thick modular panels in cushioned fabric upholstery with 30mm thick MDF board tabletop in High Pressure Laminate finish, w/ Skirting/Base 100mm (H) powder-coated aluminum panel with raceway for cables and three (3) knockouts for UPS / Normal Power / Datacom outlets</i></p>		
	1. Modular Panels		
	2pcs	Fabric Screen Panel, Two-Tone, 1650mm W x 900mm H x 50mm thk	
	1pc	Fabric Screen Panel, Two-Tone, 1500mm W x 900mm H x 50mm thk	
	2pcs	Fabric Screen Panel, Two-Tone, 600mm W x 900mm H x 50mm thk	
	2pcs	Fabric Screen Panel, Two-Tone, 600mm W x 720mm H x 50mm thk	
	2pcs	Aluminum Corner Post, 3-way 900mm H	
	2pcs	Aluminum Corner Post, 2-way 900mm H	
	2pcs	Aluminum End Trim, 900mm H	
	2pcs	Aluminum End Trim, 720mm H	
	1pc	Aluminum End Trim, 150mm H	
	2. Worktop		
	1pc	Rectangular Work Top, 1650mm L x 600mm D x 30mm thk MDF board in HPL finish with 2mm thick PVC edging and two (2) plastic grommet with rotating cover for every work surfaces.	
	1pc	Rectangular Work Top, 1500mm L x 600mm D x 30mm thk MDF board in HPL finish with 2mm thick PVC edging and two (2) plastic grommet with rotating cover for every work surfaces.	
	1pc	Irregular Work Top, 1.10 m ² x 30mm thk MDF board in HPL finish (see Annex 1)	
	3. Accessories		
	3pcs	Keyboard Tray, Hard Plastic	
	<p>Color/Finishes: Specific Color/finishes subject for approval Modular panel Fabric Upholstery: Two-tone, Titch brand fabric or approved equal. Top: Titch “Sunrise”; Bottom: Titch “Expensive Blue”</p> <p>High Pressure Laminate Finish: Formica or WilsonArt Laminates Tabletop: Folkstone “0927”</p>		



Item	Specifications	Statement of Compliance														
	Aluminum Extrusions: Powder coated finish. Submit sample for approval															
K	<p>1-Seater Staff/Nonsupervisor's Workstation 2 - 1 set (High partition with with quarter glass)</p> <p><i>Modular workstation with 50mm thick modular panels in cushioned fabric upholstery with 30mm thick MDF board tabletop in High Pressure Laminate finish, w/ Skirting/Base 100mm (H) powder-coated aluminum panel with raceway for cables and three (3) knockouts for UPS / Normal Power / Datacom outlets</i></p>															
L	<p>1. Modular Panels</p> <table border="1" data-bbox="297 680 1211 908"> <tr> <td data-bbox="297 680 396 749">1pc</td> <td data-bbox="396 680 1211 749">Fabric Screen Panel, Two-Tone, 1200mm W x 1200mm H x 50mm thk</td> </tr> <tr> <td data-bbox="297 749 396 819">2pcs</td> <td data-bbox="396 749 1211 819">Fabric Screen Panel, Two-Tone, 600mm W x 1200mm H x 50mm thk with quarter glass</td> </tr> <tr> <td data-bbox="297 819 396 862">2pcs</td> <td data-bbox="396 819 1211 862">Aluminum Corner Post, 2-way 1200mm H</td> </tr> <tr> <td data-bbox="297 862 396 908">2pcs</td> <td data-bbox="396 862 1211 908">Aluminum End Trim, 1200mm H</td> </tr> </table> <p>2. Worktop</p> <table border="1" data-bbox="297 948 1211 1096"> <tr> <td data-bbox="297 948 396 1096">1pc</td> <td data-bbox="396 948 1211 1096">Rectangular Work Top, 1200mm L x 600mm D x 30mm thk MDF board in HPL finish with 2mm thick PVC edging and two (2) plastic grommet with rotating cover for every work surfaces.</td> </tr> </table> <p>3. Accessories</p> <table border="1" data-bbox="297 1137 1211 1177"> <tr> <td data-bbox="297 1137 396 1177">1pc</td> <td data-bbox="396 1137 1211 1177">Keyboard Tray, Hard Plastic</td> </tr> </table> <p>Color/Finishes: Specific Color/finishes subject for approval Modular panel Fabric Upholstery: Two-tone, Titch brand fabric or approved equal. Top: Titch "Sunrise"; Bottom: Titch "Expensive Blue"</p> <p>High Pressure Laminate Finish: Formica or WilsonArt Laminates Tabletop: Folkstone "0927"</p> <p>Aluminum Extrusions: Powder coated finish. Submit sample for approval</p> <p>2-Seater Staff/Nonsupervisor's Workstation 2 - 3 sets</p> <p><i>Modular workstation with 50mm thick modular panels in cushioned fabric upholstery with 30mm thick MDF board tabletop in High Pressure Laminate finish, w/ Skirting/Base 100mm (H) powder-coated aluminum panel with raceway for cables and three (3) knockouts for UPS / Normal Power / Datacom outlets</i></p>	1pc	Fabric Screen Panel, Two-Tone, 1200mm W x 1200mm H x 50mm thk	2pcs	Fabric Screen Panel, Two-Tone, 600mm W x 1200mm H x 50mm thk with quarter glass	2pcs	Aluminum Corner Post, 2-way 1200mm H	2pcs	Aluminum End Trim, 1200mm H	1pc	Rectangular Work Top, 1200mm L x 600mm D x 30mm thk MDF board in HPL finish with 2mm thick PVC edging and two (2) plastic grommet with rotating cover for every work surfaces.	1pc	Keyboard Tray, Hard Plastic			
1pc	Fabric Screen Panel, Two-Tone, 1200mm W x 1200mm H x 50mm thk															
2pcs	Fabric Screen Panel, Two-Tone, 600mm W x 1200mm H x 50mm thk with quarter glass															
2pcs	Aluminum Corner Post, 2-way 1200mm H															
2pcs	Aluminum End Trim, 1200mm H															
1pc	Rectangular Work Top, 1200mm L x 600mm D x 30mm thk MDF board in HPL finish with 2mm thick PVC edging and two (2) plastic grommet with rotating cover for every work surfaces.															
1pc	Keyboard Tray, Hard Plastic															
	<p>1. Modular Panels</p> <table border="1" data-bbox="297 1870 1211 2139"> <tr> <td data-bbox="297 1870 396 1940">6pcs</td> <td data-bbox="396 1870 1211 1940">Fabric Screen Panel, Two-Tone, 1200mm W x 1200mm H x 50mm thk</td> </tr> <tr> <td data-bbox="297 1940 396 2010">9pcs</td> <td data-bbox="396 1940 1211 2010">Fabric Screen Panel, Two-Tone, 600mm W x 1200mm H x 50mm thk with quarter glass</td> </tr> <tr> <td data-bbox="297 2010 396 2053">3pcs</td> <td data-bbox="396 2010 1211 2053">Aluminum Corner Post, 3-way 1200mm H</td> </tr> <tr> <td data-bbox="297 2053 396 2096">6pcs</td> <td data-bbox="396 2053 1211 2096">Aluminum Corner Post, 2-way 1200mm H</td> </tr> <tr> <td data-bbox="297 2096 396 2139">9pcs</td> <td data-bbox="396 2096 1211 2139">Aluminum End Trim, 1200mm H</td> </tr> </table> <p>2. Worktop</p> <table border="1" data-bbox="297 2179 1211 2327"> <tr> <td data-bbox="297 2179 396 2327">6pcs</td> <td data-bbox="396 2179 1211 2327">Rectangular Work Top, 1200mm L x 600mm D x 30mm thk MDF board in HPL finish with 2mm thick PVC edging and two (2) plastic grommet with rotating cover for every work surfaces.</td> </tr> </table> <p>3. Accessories</p> <table border="1" data-bbox="297 2368 1211 2408"> <tr> <td data-bbox="297 2368 396 2408">6pcs</td> <td data-bbox="396 2368 1211 2408">Keyboard Tray, Hard Plastic</td> </tr> </table>	6pcs	Fabric Screen Panel, Two-Tone, 1200mm W x 1200mm H x 50mm thk	9pcs	Fabric Screen Panel, Two-Tone, 600mm W x 1200mm H x 50mm thk with quarter glass	3pcs	Aluminum Corner Post, 3-way 1200mm H	6pcs	Aluminum Corner Post, 2-way 1200mm H	9pcs	Aluminum End Trim, 1200mm H	6pcs	Rectangular Work Top, 1200mm L x 600mm D x 30mm thk MDF board in HPL finish with 2mm thick PVC edging and two (2) plastic grommet with rotating cover for every work surfaces.	6pcs	Keyboard Tray, Hard Plastic	
6pcs	Fabric Screen Panel, Two-Tone, 1200mm W x 1200mm H x 50mm thk															
9pcs	Fabric Screen Panel, Two-Tone, 600mm W x 1200mm H x 50mm thk with quarter glass															
3pcs	Aluminum Corner Post, 3-way 1200mm H															
6pcs	Aluminum Corner Post, 2-way 1200mm H															
9pcs	Aluminum End Trim, 1200mm H															
6pcs	Rectangular Work Top, 1200mm L x 600mm D x 30mm thk MDF board in HPL finish with 2mm thick PVC edging and two (2) plastic grommet with rotating cover for every work surfaces.															
6pcs	Keyboard Tray, Hard Plastic															



Item	Specifications	Statement of Compliance														
	<p>Color/Finishes: Specific Color/finishes subject for approval Modular panel Fabric Upholstery: Two-tone, Titch brand fabric or approved equal. Top: Titch “Sunrise”; Bottom: Titch “Expensive Blue”</p> <p>High Pressure Laminate Finish: Formica or WilsonArt Laminates Tabletop: Folkstone “0927”</p> <p>Aluminum Extrusions: Powder coated finish. Submit sample for approval</p>															
M	<p>3-Seater Staff/Nonsupervisor's Workstation 2 – 1 set</p> <p><i>Modular workstation with 50mm thick modular panels in cushioned fabric upholstery with 30mm thick MDF board tabletop in High Pressure Laminate finish, w/ Skirting/Base 100mm (H) powder-coated aluminum panel with raceway for cables and three (3) knockouts for UPS / Normal Power / Datacom outlets</i></p>															
	<p>1. Modular Panels</p> <table border="1" data-bbox="297 962 1211 1231"> <tr> <td data-bbox="297 962 391 1042">3pcs</td> <td data-bbox="391 962 1211 1042">Fabric Screen Panel, Two-Tone, 1500mm W x 1200mm H x 50mm thk</td> </tr> <tr> <td data-bbox="297 1042 391 1123">4pcs</td> <td data-bbox="391 1042 1211 1123">Fabric Screen Panel, Two-Tone, 600mm W x 1200mm H x 50mm thk with quarter glass</td> </tr> <tr> <td data-bbox="297 1123 391 1163">2pcs</td> <td data-bbox="391 1123 1211 1163">Aluminum Corner Post, 3-way 1200mm H</td> </tr> <tr> <td data-bbox="297 1163 391 1204">2pcs</td> <td data-bbox="391 1163 1211 1204">Aluminum Corner Post, 2-way 1200mm H</td> </tr> <tr> <td data-bbox="297 1204 391 1244">4pcs</td> <td data-bbox="391 1204 1211 1244">Aluminum End Trim, 1200mm H</td> </tr> </table> <p>2. Worktop</p> <table border="1" data-bbox="297 1271 1211 1419"> <tr> <td data-bbox="297 1271 391 1419">3pcs</td> <td data-bbox="391 1271 1211 1419">Rectangular Work Top, 1200mm L x 600mm D x 30mm thk MDF board in HPL finish with 2mm thick PVC edging and two (2) plastic grommet with rotating cover for every work surfaces.</td> </tr> </table> <p>3. Accessories</p> <table border="1" data-bbox="297 1446 1211 1499"> <tr> <td data-bbox="297 1446 391 1499">3pcs</td> <td data-bbox="391 1446 1211 1499">Keyboard Tray, Hard Plastic</td> </tr> </table> <p>Color/Finishes: Specific Color/finishes subject for approval Modular panel Fabric Upholstery: Two-tone, Titch brand fabric or approved equal. Top: Titch “Sunrise”; Bottom: Titch “Expensive Blue”</p> <p>High Pressure Laminate Finish: Formica or WilsonArt Laminates Tabletop: Folkstone “0927”</p> <p>Aluminum Extrusions: Powder coated finish. Submit sample for approval</p>	3pcs	Fabric Screen Panel, Two-Tone, 1500mm W x 1200mm H x 50mm thk	4pcs	Fabric Screen Panel, Two-Tone, 600mm W x 1200mm H x 50mm thk with quarter glass	2pcs	Aluminum Corner Post, 3-way 1200mm H	2pcs	Aluminum Corner Post, 2-way 1200mm H	4pcs	Aluminum End Trim, 1200mm H	3pcs	Rectangular Work Top, 1200mm L x 600mm D x 30mm thk MDF board in HPL finish with 2mm thick PVC edging and two (2) plastic grommet with rotating cover for every work surfaces.	3pcs	Keyboard Tray, Hard Plastic	
3pcs	Fabric Screen Panel, Two-Tone, 1500mm W x 1200mm H x 50mm thk															
4pcs	Fabric Screen Panel, Two-Tone, 600mm W x 1200mm H x 50mm thk with quarter glass															
2pcs	Aluminum Corner Post, 3-way 1200mm H															
2pcs	Aluminum Corner Post, 2-way 1200mm H															
4pcs	Aluminum End Trim, 1200mm H															
3pcs	Rectangular Work Top, 1200mm L x 600mm D x 30mm thk MDF board in HPL finish with 2mm thick PVC edging and two (2) plastic grommet with rotating cover for every work surfaces.															
3pcs	Keyboard Tray, Hard Plastic															
N	<p>6-Seater Staff/Nonsupervisor's Workstation 2 – 1 set</p> <p><i>Modular workstation with 50mm thick modular panels in cushioned fabric upholstery with 30mm thick MDF board tabletop in High Pressure Laminate finish, w/ Skirting/Base 100mm (H) powder-coated aluminum panel with raceway for cables and three (3) knockouts for UPS / Normal Power / Datacom outlets</i></p>															
	<p>1. Modular Panels</p> <table border="1" data-bbox="297 2190 1211 2451"> <tr> <td data-bbox="297 2190 391 2271">3pcs</td> <td data-bbox="391 2190 1211 2271">Fabric Screen Panel, Two-Tone, 1500mm W x 1200mm H x 50mm thk</td> </tr> <tr> <td data-bbox="297 2271 391 2352">8pcs</td> <td data-bbox="391 2271 1211 2352">Fabric Screen Panel, Two-Tone, 600mm W x 1200mm H x 50mm thk with quarter glass</td> </tr> <tr> <td data-bbox="297 2352 391 2392">2pcs</td> <td data-bbox="391 2352 1211 2392">Aluminum Corner Post, 4-way 1200mm H</td> </tr> <tr> <td data-bbox="297 2392 391 2432">2pcs</td> <td data-bbox="391 2392 1211 2432">Aluminum Corner Post, 3-way 1200mm H</td> </tr> <tr> <td data-bbox="297 2432 391 2451">8pcs</td> <td data-bbox="391 2432 1211 2451">Aluminum End Trim, 1200mm H</td> </tr> </table>	3pcs	Fabric Screen Panel, Two-Tone, 1500mm W x 1200mm H x 50mm thk	8pcs	Fabric Screen Panel, Two-Tone, 600mm W x 1200mm H x 50mm thk with quarter glass	2pcs	Aluminum Corner Post, 4-way 1200mm H	2pcs	Aluminum Corner Post, 3-way 1200mm H	8pcs	Aluminum End Trim, 1200mm H					
3pcs	Fabric Screen Panel, Two-Tone, 1500mm W x 1200mm H x 50mm thk															
8pcs	Fabric Screen Panel, Two-Tone, 600mm W x 1200mm H x 50mm thk with quarter glass															
2pcs	Aluminum Corner Post, 4-way 1200mm H															
2pcs	Aluminum Corner Post, 3-way 1200mm H															
8pcs	Aluminum End Trim, 1200mm H															



Item	Specifications	Statement of Compliance																
	<p>2. Worktop</p> <table border="1" data-bbox="297 301 1211 448"> <tr> <td data-bbox="297 301 396 448">6pcs</td> <td data-bbox="396 301 1211 448">Rectangular Work Top, 1200mm L x 600mm D x 30mm thk MDF board in HPL finish with 2mm thick PVC edging and two (2) plastic grommet with rotating cover for every work surfaces.</td> </tr> </table> <p>3. Accessories</p> <table border="1" data-bbox="297 489 1211 529"> <tr> <td data-bbox="297 489 396 529">6pcs</td> <td data-bbox="396 489 1211 529">Keyboard Tray, Hard Plastic</td> </tr> </table> <p>Color/Finishes: Specific Color/finishes subject for approval Modular panel Fabric Upholstery: Two-tone, Titch brand fabric or approved equal. Top: Titch “Sunrise”; Bottom: Titch “Expensive Blue”</p> <p>High Pressure Laminate Finish: Formica or WilsonArt Laminates Tabletop: Folkstone “0927”</p> <p>Aluminum Extrusions: Powder coated finish. Submit sample for approval</p>	6pcs	Rectangular Work Top, 1200mm L x 600mm D x 30mm thk MDF board in HPL finish with 2mm thick PVC edging and two (2) plastic grommet with rotating cover for every work surfaces.	6pcs	Keyboard Tray, Hard Plastic													
6pcs	Rectangular Work Top, 1200mm L x 600mm D x 30mm thk MDF board in HPL finish with 2mm thick PVC edging and two (2) plastic grommet with rotating cover for every work surfaces.																	
6pcs	Keyboard Tray, Hard Plastic																	
O	<p>7-Seater Staff/Nonsupervisor's Workstation 2 – 1 set</p> <p><i>Modular workstation with 50mm thick modular panels in cushioned fabric upholstery with 30mm thick MDF board tabletop in High Pressure Laminate finish, w/ Skirting/Base 100mm (H) powder-coated aluminum panel with raceway for cables and three (3) knockouts for UPS / Normal Power / Datacom outlets</i></p>																	
	<p>1. Modular Panels</p> <table border="1" data-bbox="297 1225 1211 1526"> <tr> <td data-bbox="297 1225 396 1292">4pcs</td> <td data-bbox="396 1225 1211 1292">Fabric Screen Panel, Two-Tone, 1500mm W x 1200mm H x 50mm thk</td> </tr> <tr> <td data-bbox="297 1292 396 1373">9pcs</td> <td data-bbox="396 1292 1211 1373">Fabric Screen Panel, Two-Tone, 600mm W x 1200mm H x 50mm thk with quarter glass</td> </tr> <tr> <td data-bbox="297 1373 396 1413">3pcs</td> <td data-bbox="396 1373 1211 1413">Aluminum Corner Post, 4-way 1200mm H</td> </tr> <tr> <td data-bbox="297 1413 396 1454">1pc</td> <td data-bbox="396 1413 1211 1454">Aluminum Corner Post, 3-way 1200mm H</td> </tr> <tr> <td data-bbox="297 1454 396 1494">1pc</td> <td data-bbox="396 1454 1211 1494">Aluminum Corner Post, 2-way 1200mm H</td> </tr> <tr> <td data-bbox="297 1494 396 1534">9pcs</td> <td data-bbox="396 1494 1211 1534">Aluminum End Trim, 1200mm H</td> </tr> </table> <p>2. Worktop</p> <table border="1" data-bbox="297 1575 1211 1723"> <tr> <td data-bbox="297 1575 396 1723">7pcs</td> <td data-bbox="396 1575 1211 1723">Rectangular Work Top, 1200mm L x 600mm D x 30mm thk MDF board in HPL finish with 2mm thick PVC edging and two (2) plastic grommet with rotating cover for every work surfaces.</td> </tr> </table> <p>3. Accessories</p> <table border="1" data-bbox="297 1763 1211 1803"> <tr> <td data-bbox="297 1763 396 1803">7pcs</td> <td data-bbox="396 1763 1211 1803">Keyboard Tray, Hard Plastic</td> </tr> </table> <p>Color/Finishes: Specific Color/finishes subject for approval Modular panel Fabric Upholstery: Two-tone, Titch brand fabric or approved equal. Top: Titch “Sunrise”; Bottom: Titch “Expensive Blue”</p> <p>High Pressure Laminate Finish: Formica or WilsonArt Laminates Tabletop: Folkstone “0927”</p> <p>Aluminum Extrusions: Powder coated finish. Submit sample for approval</p>	4pcs	Fabric Screen Panel, Two-Tone, 1500mm W x 1200mm H x 50mm thk	9pcs	Fabric Screen Panel, Two-Tone, 600mm W x 1200mm H x 50mm thk with quarter glass	3pcs	Aluminum Corner Post, 4-way 1200mm H	1pc	Aluminum Corner Post, 3-way 1200mm H	1pc	Aluminum Corner Post, 2-way 1200mm H	9pcs	Aluminum End Trim, 1200mm H	7pcs	Rectangular Work Top, 1200mm L x 600mm D x 30mm thk MDF board in HPL finish with 2mm thick PVC edging and two (2) plastic grommet with rotating cover for every work surfaces.	7pcs	Keyboard Tray, Hard Plastic	
4pcs	Fabric Screen Panel, Two-Tone, 1500mm W x 1200mm H x 50mm thk																	
9pcs	Fabric Screen Panel, Two-Tone, 600mm W x 1200mm H x 50mm thk with quarter glass																	
3pcs	Aluminum Corner Post, 4-way 1200mm H																	
1pc	Aluminum Corner Post, 3-way 1200mm H																	
1pc	Aluminum Corner Post, 2-way 1200mm H																	
9pcs	Aluminum End Trim, 1200mm H																	
7pcs	Rectangular Work Top, 1200mm L x 600mm D x 30mm thk MDF board in HPL finish with 2mm thick PVC edging and two (2) plastic grommet with rotating cover for every work surfaces.																	
7pcs	Keyboard Tray, Hard Plastic																	
P	<p>8-Seater Staff/Nonsupervisor's Workstation 2 – 2 sets</p> <p><i>Modular workstation with 50mm thick modular panels in cushioned fabric upholstery with 30mm thick MDF board tabletop in High Pressure Laminate finish, w/ Skirting/Base 100mm (H) powder-coated aluminum panel with raceway for cables and three (3) knockouts for UPS / Normal Power / Datacom outlets</i></p>																	



Item	Specifications	Statement of Compliance																								
	<p>1. Modular Panels</p> <table border="1"> <tr> <td data-bbox="297 303 396 373">8pcs</td> <td data-bbox="396 303 1211 373">Fabric Screen Panel, Two-Tone, 1500mm W x 1200mm H x 50mm thk</td> </tr> <tr> <td data-bbox="297 373 396 443">20pcs</td> <td data-bbox="396 373 1211 443">Fabric Screen Panel, Two-Tone, 600mm W x 1200mm H x 50mm thk with quarter glass</td> </tr> <tr> <td data-bbox="297 443 396 486">6pcs</td> <td data-bbox="396 443 1211 486">Aluminum Corner Post, 4-way 1200mm H</td> </tr> <tr> <td data-bbox="297 486 396 529">4pcs</td> <td data-bbox="396 486 1211 529">Aluminum Corner Post, 3-way 1200mm H</td> </tr> <tr> <td data-bbox="297 529 396 572">20pcs</td> <td data-bbox="396 529 1211 572">Aluminum End Trim, 1200mm H</td> </tr> </table> <p>2. Worktop</p> <table border="1"> <tr> <td data-bbox="297 612 396 749">16pcs</td> <td data-bbox="396 612 1211 749">Rectangular Work Top, 1200mm L x 600mm D x 30mm thk MDF board in HPL finish with 2mm thick PVC edging and two (2) plastic grommet with rotating cover for every work surfaces.</td> </tr> </table> <p>3. Accessories</p> <table border="1"> <tr> <td data-bbox="297 790 396 833">16pcs</td> <td data-bbox="396 790 1211 833">Keyboard Tray, Hard Plastic</td> </tr> </table> <p>Color/Finishes: Specific Color/finishes subject for approval Modular panel Fabric Upholstery: Two-tone, Titch brand fabric or approved equal. Top: Titch “Sunrise”; Bottom: Titch “Expensive Blue”</p> <p>High Pressure Laminate Finish: Formica or WilsonArt Laminates Tabletop: Folkstone “0927”</p> <p>Aluminum Extrusions: Powder coated finish. Submit sample for approval</p>	8pcs	Fabric Screen Panel, Two-Tone, 1500mm W x 1200mm H x 50mm thk	20pcs	Fabric Screen Panel, Two-Tone, 600mm W x 1200mm H x 50mm thk with quarter glass	6pcs	Aluminum Corner Post, 4-way 1200mm H	4pcs	Aluminum Corner Post, 3-way 1200mm H	20pcs	Aluminum End Trim, 1200mm H	16pcs	Rectangular Work Top, 1200mm L x 600mm D x 30mm thk MDF board in HPL finish with 2mm thick PVC edging and two (2) plastic grommet with rotating cover for every work surfaces.	16pcs	Keyboard Tray, Hard Plastic											
8pcs	Fabric Screen Panel, Two-Tone, 1500mm W x 1200mm H x 50mm thk																									
20pcs	Fabric Screen Panel, Two-Tone, 600mm W x 1200mm H x 50mm thk with quarter glass																									
6pcs	Aluminum Corner Post, 4-way 1200mm H																									
4pcs	Aluminum Corner Post, 3-way 1200mm H																									
20pcs	Aluminum End Trim, 1200mm H																									
16pcs	Rectangular Work Top, 1200mm L x 600mm D x 30mm thk MDF board in HPL finish with 2mm thick PVC edging and two (2) plastic grommet with rotating cover for every work surfaces.																									
16pcs	Keyboard Tray, Hard Plastic																									
Q	<p>1-Seater Staff/Nonsupervisor's Workstation 3 – 1 set</p> <p><i>Modular workstation with 50mm thick modular panels in cushioned fabric upholstery with 30mm thick MDF board tabletop in High Pressure Laminate finish, w/ Skirting/Base 100mm (H) powder-coated aluminum panel with raceway for cables and three (3) knockouts for UPS / Normal Power / Datacom outlets</i></p>																									
	<p>1. Modular Panels</p> <table border="1"> <tr> <td data-bbox="297 1529 396 1599">1pc</td> <td data-bbox="396 1529 1211 1599">Fabric Screen Panel, Two-Tone, 900mm W x 1200mm H x 50mm thk</td> </tr> <tr> <td data-bbox="297 1599 396 1669">1pc</td> <td data-bbox="396 1599 1211 1669">Fabric Screen Panel, Two-Tone, 600mm W x 1200mm H x 50mm thk</td> </tr> <tr> <td data-bbox="297 1669 396 1739">1pc</td> <td data-bbox="396 1669 1211 1739">Fabric Screen Panel, Two-Tone, 400mm W x 1200mm H x 50mm thk</td> </tr> <tr> <td data-bbox="297 1739 396 1809">1pc</td> <td data-bbox="396 1739 1211 1809">Fabric Screen Panel, Two-Tone, 1200mm W x 900mm H x 50mm thk</td> </tr> <tr> <td data-bbox="297 1809 396 1878">1pc</td> <td data-bbox="396 1809 1211 1878">Fabric Screen Panel, Two-Tone, 600mm W x 900mm H x 50mm thk</td> </tr> <tr> <td data-bbox="297 1878 396 1921">2pc</td> <td data-bbox="396 1878 1211 1921">Aluminum Corner Post, 2-way 1200mm H</td> </tr> <tr> <td data-bbox="297 1921 396 1964">1pc</td> <td data-bbox="396 1921 1211 1964">Aluminum Corner Post, 2-way 900mm H</td> </tr> <tr> <td data-bbox="297 1964 396 2007">1pc</td> <td data-bbox="396 1964 1211 2007">Aluminum End Trim, 1200mm H</td> </tr> <tr> <td data-bbox="297 2007 396 2050">1pc</td> <td data-bbox="396 2007 1211 2050">Aluminum End Trim, 900mm H</td> </tr> <tr> <td data-bbox="297 2050 396 2093">1pc</td> <td data-bbox="396 2050 1211 2093">Aluminum End Trim, 300mm H</td> </tr> </table> <p>2. Worktop</p> <table border="1"> <tr> <td data-bbox="297 2134 396 2271">1pc</td> <td data-bbox="396 2134 1211 2271">Rectangular Work Top, 1200mm L x 600mm D x 30mm thk MDF board in HPL finish with 2mm thick PVC edging and two (2) plastic grommet with rotating cover for every work surfaces.</td> </tr> <tr> <td data-bbox="297 2271 396 2408">1pc</td> <td data-bbox="396 2271 1211 2408">Rectangular Work Top, 900mm L x 400mm D x 30mm thk MDF board in HPL finish with 2mm thick PVC edging and two (2) plastic grommet with rotating cover for every work surfaces.</td> </tr> </table> <p>3. Accessories</p>	1pc	Fabric Screen Panel, Two-Tone, 900mm W x 1200mm H x 50mm thk	1pc	Fabric Screen Panel, Two-Tone, 600mm W x 1200mm H x 50mm thk	1pc	Fabric Screen Panel, Two-Tone, 400mm W x 1200mm H x 50mm thk	1pc	Fabric Screen Panel, Two-Tone, 1200mm W x 900mm H x 50mm thk	1pc	Fabric Screen Panel, Two-Tone, 600mm W x 900mm H x 50mm thk	2pc	Aluminum Corner Post, 2-way 1200mm H	1pc	Aluminum Corner Post, 2-way 900mm H	1pc	Aluminum End Trim, 1200mm H	1pc	Aluminum End Trim, 900mm H	1pc	Aluminum End Trim, 300mm H	1pc	Rectangular Work Top, 1200mm L x 600mm D x 30mm thk MDF board in HPL finish with 2mm thick PVC edging and two (2) plastic grommet with rotating cover for every work surfaces.	1pc	Rectangular Work Top, 900mm L x 400mm D x 30mm thk MDF board in HPL finish with 2mm thick PVC edging and two (2) plastic grommet with rotating cover for every work surfaces.	
1pc	Fabric Screen Panel, Two-Tone, 900mm W x 1200mm H x 50mm thk																									
1pc	Fabric Screen Panel, Two-Tone, 600mm W x 1200mm H x 50mm thk																									
1pc	Fabric Screen Panel, Two-Tone, 400mm W x 1200mm H x 50mm thk																									
1pc	Fabric Screen Panel, Two-Tone, 1200mm W x 900mm H x 50mm thk																									
1pc	Fabric Screen Panel, Two-Tone, 600mm W x 900mm H x 50mm thk																									
2pc	Aluminum Corner Post, 2-way 1200mm H																									
1pc	Aluminum Corner Post, 2-way 900mm H																									
1pc	Aluminum End Trim, 1200mm H																									
1pc	Aluminum End Trim, 900mm H																									
1pc	Aluminum End Trim, 300mm H																									
1pc	Rectangular Work Top, 1200mm L x 600mm D x 30mm thk MDF board in HPL finish with 2mm thick PVC edging and two (2) plastic grommet with rotating cover for every work surfaces.																									
1pc	Rectangular Work Top, 900mm L x 400mm D x 30mm thk MDF board in HPL finish with 2mm thick PVC edging and two (2) plastic grommet with rotating cover for every work surfaces.																									

Item	Specifications		Statement of Compliance
	1pc	Keyboard Tray, Hard Plastic	
	<p>Color/Finishes: Specific Color/finishes subject for approval</p> <p>Modular panel Fabric Upholstery: Two-tone, Titch brand fabric or approved equal.</p> <p>Top: Titch “Sunrise”;</p> <p>Bottom: Titch “Expensive Blue”</p> <p>High Pressure Laminate Finish: Formica or WilsonArt Laminates</p> <p>Tabletop: Folkstone “0927”</p> <p>Aluminum Extrusions: Powder coated finish. Submit sample for approval</p>		
	Desks and Tables		
R	1 pc	Free Standing Computer Table in MDF Board Tabletop in HPL Finish	
	4pcs	Meeting Table (4-Seater, Round Shape 900mm dia.) MDF board in HPL finish	
	2pcs	Conference Foldable Free Standing Table, 30mm THK MDF Board in HPL Finish, 1500mm (L) x 600mm (D) x 750mm (H), Post-Formed Front & Back Edges with Ga. 18 Legs Support Powder-Coated Finish	
II	SEATING FURNITURE		
	3pcs	<p>Executive Chair</p> <p><i>High-back swivel chair with synchronized tilt and swivel mechanism, recline and rocking feature, pneumatic seat height adjustment, rounded profile backrest with integral headrest, fixed padded armrest and 5-prong base.</i></p> <p>Backrest: 730 mm (H) x 490 mm (W)</p> <p>Reclining backrest with lumbar support made of plastic shell with high density molded foam, leatherette upholstery and rocking feature.</p> <p>Tilt: Synchronized tilt/swivel mechanism that allows tilting forward at 80° and backward at 110°, with tilt tension adjustment, control lever that releases tilt for free float of backrest or tilt lock in a specific angle and safety feature that allows non-movement of backrest upon initial unlocking of lever.</p> <p>Seat: 490 mm (W) x 470 mm (D)</p> <p>Plastic shell with high density molded foam and upholstery.</p> <p>Armrest: 240 mm - 300 mm</p> <p>High Quality Chrome Solid Aluminum Fixed armrest and black upholstered pads</p> <p>Color: (submit sample for approval)</p> <p>Upholstery – Black Leatherette</p> <p>Frame /Base - Black nylon or glossy/satin metal finish</p>	
	5pcs	<p>Supervisor's Chair</p> <p><i>Mid-back swivel chair with synchronized tilt mechanism, pneumatic seat height adjustment, fixed contoured polypropylene armrest and 5-prong base</i></p> <p>Backrest height: 550 mm with lumbar support made of plastic shell and cushioned with high density molded foam</p>	



Item	Specifications	Statement of Compliance
	<p>Tilt: Synchronized tilt/swivel mechanism that allows tilting forward at 80° and backward at 110°, with tilt tension adjustment, control lever that releases tilt for free float of backrest or tilt lock in a specific angle and safety feature that allows non-movement of backrest upon initial unlocking of lever</p> <p>Seat width: 490 mm Plastic shell with high density molded foam (Uratex or approved equal)</p> <p>Armrest: Fixed contoured polypropylene arm frame and armrest. Gas lift mechanism: 28mm diameter gas cylinder head with outer tube diameter of 50 – 60 mm, German Brand gas lift mechanism (Stabilus or approved equal) Manufacturer's Certification required</p> <p>Wheel Casters: 50 mm diameter twin wheel casters, nylon type</p> <p>Base: 5-prong metal or nylon base with crisscrossed inner core; load capacity of not less than 250 lbs (Manufacturer's Certification required)</p> <p>Color: (submit sample for approval) Upholstery – Black Leatherette Frame /Base - Black nylon or glossy/satin metal finish</p>	
63pcs	<p>Non-Supervisor's Chair/Staff Chair</p> <p><i>Low back swivel chair with pneumatic seat height adjustment, single position tilt lock, molded polypropylene armrest and 5-prong nylon base</i></p> <p>Backrest height: 460 mm with lumbar support made of plastic shell with high density molded foam</p> <p>Tilt: Single position tilt lock or control lever which releases tilt for free float of backrest</p> <p>Seat: Width: 490 mm Height: 584 mm to 838 mm Plastic shell with high density molded foam (Uratex or approved equal)</p> <p>Armrest: Fixed molded polypropylene arm frame and armrest</p> <p>Gas lift mechanism: 28mm diameter gas cylinder head with outer tube diameter of 50 – 60 mm, (Stabilus brand or approved equal) Manufacturer's certification required</p> <p>Wheel Casters: 50 mm diameter twin wheel casters, nylon type</p> <p>Base: 5-prong metal or nylon base with crisscrossed inner core; load capacity of not less than 250 lbs (Manufacturer's Certification required)</p> <p>Color: Upholstery – Clerical Chair – Black Leatherette Frame /Base - Black nylon or glossy/satin metal finish</p>	



Item	Specifications	Statement of Compliance
20pcs	<p>Non-Supervisor's Clerical/Meeting/Conference Table Chair <i>Low back swivel chair with pneumatic seat height adjustment, single position tilt lock, molded polypropylene armrest and 5-prong nylon base</i></p> <p>Backrest height: 460 mm with lumbar support made of plastic shell with high density molded foam</p> <p>Tilt: Single position tilt lock or control lever which releases tilt for free float of backrest</p> <p>Seat: Width: 490 mm Height: 584 mm to 838 mm Plastic shell with high density molded foam (Uratex or approved equal)</p> <p>Gas lift mechanism: 28mm diameter gas cylinder head with outer tube diameter of 50 – 60 mm, (Stabilus brand or approved equal) Manufacturer's certification required</p> <p>Wheel Casters: 50 mm diameter twin wheel casters, nylon type</p> <p>Base: 5-prong metal or nylon base with crisscrossed inner core; load capacity of not less than 250 lbs (Manufacturer's Certification required)</p> <p>Color: (submit sample for approval) Conference Chair – Pantone Blue, FabricFrame /Base - Black nylon or glossy/satin metal finish</p>	
6pcs	<p>Guest Chair 1, 2-piece, Midback, Cantilever Type (For Executive) w/ Armrest <i>Mid-back chair with cantilever tubular legs, cushioned seat and backrest, polypropylene armrest and cantilever legs</i></p> <p>Backrest and Seat: Polypropylene back and seat with 2” thick high density molded foam cushion (Uratex or approved equal) with leatherette upholstery</p> <p>Legs: tubular legs in powder-coated finish, cantilever-type; load capacity of not less than 250 lbs (Manufacturer's Certification is required)</p> <p>Arm/armrest: Fixed polypropylene armrest</p> <p>Color: Upholstery – Pantone Blue, Fabric Frame /Base - Black</p>	
3pcs	<p>Guest Chair 2 Low back chair with sled base in powder-coated finish; with armrest</p> <p>Backrest and Seat: Polypropylene back and seat with high density molded foam cushion (Uratex or approved equal), fabric upholstery and “waterfall” seat profile</p> <p>Seat Support: Parallel or intersecting (“X”) seat support in tubular metal frame with seamless weld</p> <p>Frame/Legs: 18 mm (min.) diameter powder-coated tubular frame; sled-type base; black</p>	



Item	Specifications		Statement of Compliance
		<p>Color: Upholstery – Pantone Blue, fabric</p>	
6pcs		<p>Stackable Chair <i>2-piece low back chair with steel tubular frame and sled base in powder-coated finish; without armrest.</i></p> <p>Backrest and seat: Polypropylene back and seat; without cushion and upholstery.</p> <p>Seat support: Parallel or intersecting (“X”) seat support in tubular metal frame with seamless weld.</p> <p>Frame/Legs: 18 mm diameter powder-coated steel tube welded frame; sled base and stackable; blackClip/Connector: Heavy-duty PVC clip</p> <p>Color: PP seat & back: Royal Blue</p>	
III	CONTRACT FURNITURE		
3pcs		<p>Manager's Back Cabinet, 1800mm W x 450mm D x 750mm H 19mm THK Marine Plywood with 2mm thick pvc edging same color with the HPL finish in PVC Film Finish or Approved Equal w/ 3 drawers and cabinets 3/4” thick Marine Plywood in HPL finish with Stainless Steel Handle</p> <p>Color/Finishes: High Pressure Laminate Finish: Formica or WilsonArt Body: Lincoln Walnut code "7188"</p>	
IV	STEEL SHELVES, CABINETS & DRAWERS		
71pcs		<p>Mobile Pedestal Drawer 400mm W x 560mm D x 650mm H <i>Cold Rolled steel with high quality powder coating finish with three (3) layer drawers in powder coated finish, with full extension ball-bearing slides, central lock system, recessed drawer pulls, with 2 pcs stationery tray/organizer and heavy-duty caster wheels</i></p> <p>Body/Case: Manufactured in cold rolled sheet Ga. #22 (0.80mm) in powder coated finish</p> <p>Pull-out Drawer: Fabricated in cold rolled sheet Ga. #24 (0.60 mm) with central control lock on the top drawer Rail: Made in cold rolled sheet Ga. #20 (0.90mm), hang on roller bearing in powder coated finish Casters: Lockable Caster Wheel with fifth wheel for stability Color: Light Gray (Submit sample for approval)</p>	



Item	Specifications	Statement of Compliance
3pcs	<p>4 Drawer Lateral Filing Cabinet 900mm (W) x 500mm (D) x 1380mm (H) <i>Powder-coated steel filing cabinet with four (4) pull-out drawers in metal glides, adjustable steel file dividers, anti-tilt mechanism, anti-tilt counterweight located at the bottom, built-in full recessed pull and central locking mechanism; Cold rolled metal sheets in powder-coated finish, heavy-duty drawer suspension in ball bearing and zinc chromate finish with the following thickness</i></p> <p>Pull-out Drawer: Fabricated in cold rolled shell Ga. #22 (0.80 mm) with 2 steel file divider and built-in PVC flush handle per drawer. Heavy-duty drawer suspension in ball-bearing slides and zinc chromate finish, with a minimum load capacity of 50 kgs/drawer (Manufacturer's certification required)</p> <p>Interior Supports / Braces: 1.20 mm (Gauge # 18) cold-rolled steel</p> <p>Carcase / Shell: Manufactured in cold rolled sheet Ga. #20 (0.90mm) with vertical support both sides, welded</p> <p>Rail: Made in heavy duty cold rolled sheet Ga. 17 (1.40mm) in full extension suspension on roller bearing in powder coated finish. With a minimum load capacity of 50kgs/drawer. (Manufacturer's Certification required)</p> <p>Color: Light Gray (Submit sample for approval)</p>	
V.	GENERAL SPECIFICATIONS AND CONDITIONS	
1.	Hooks and brackets shall be provided with locking devices to prevent accidental dismounting of worktop when attached to the panels/supports. Panels that are perpendicular or parallel to a fix wall shall be anchored to the wall using metal connectors, otherwise all assemblies shall be properly anchored to the floor.	
2.	Modular panels shall be fully interchangeable and can be dismantled or assembled without the use of special tools.	
3.	Panels and worktops with thickness that are not commercially available shall be fabricated using the same material, laminated together using appropriate adhesives and applicable technology.	
4.	Materials or accessories deemed necessary to complete the modular workstations but not specifically mentioned in the Specifications, Bid Breakdown Form, working drawings or in the other contract documents are inferred and shall be supplied, installed and rendered by the contractor without extra cost to the owner. Such material shall be of the highest quality available and installed in an appropriate manner.	



*Section VIII. Checklist of Technical and
Financial Documents*

CHECKLIST OF TECHNICAL AND FINANCIAL DOCUMENTS



I. TECHNICAL COMPONENT ENVELOPE

Class "A" Documents

Legal Documents

- (a) Valid PhilGEPS Registration Certificate (Platinum Membership) (all pages); if non- Platinum members, submit the following:
- (b) PhilGEPS Registration, and
- (c) Registration certificate from Securities and Exchange Commission (SEC), Department of Trade and Industry (DTI) for sole proprietorship, or Cooperative Development Authority (CDA) for cooperatives or its equivalent document,
And
- (d) Mayor's or Business permit issued by the city or municipality where the principal place of business of the prospective bidder is located, or the equivalent document for Exclusive Economic Zones or Areas;
And
- (e) Tax clearance per E.O. No. 398, s. 2005, as finally reviewed and approved by the Bureau of Internal Revenue (BIR).

Technical Documents

- (f) Statement of the prospective bidder of all its ongoing government and private contracts, including contracts awarded but not yet started, if any, whether similar or not similar in nature and complexity to the contract to be bid; **and**
- (g) Statement of the bidder's Single Largest Completed Contract (SLCC) similar to the contract to be bid, except under conditions provided for in Sections 23.4.1.3 and 23.4.2.4 of the 2016 revised IRR of RA No. 9184, **within five (5) years period prior to the submission and opening of Bids; and**
- (h) Original copy of Bid Security (Cash, Letter of Credit, Surety Bond). If in the form of a Surety Bond, submit also a certification issued by the Insurance Commission; **Or** Original copy of Notarized Bid Securing Declaration; **and**
- (i) Conformity with the Schedule of Requirements (Section VI) and Technical Specifications (Section VII), which may include production/delivery schedule, manpower requirements, and/or after-sales/parts, if applicable; **and**
- (j) Original duly signed Omnibus Sworn Statement (OSS); **and** if applicable, Original Notarized Secretary's Certificate in case of a corporation, partnership, or cooperative; or Original Special Power of Attorney of all members of the joint venture giving full power and authority to its officer to sign the OSS and do acts to represent the Bidder and copy Authority to Notarize issued to the Notary Public by the Regional Trial Court.

Other documentary requirements under RA No. 9184 (as applicable)

For foreign bidders claiming by reason of their country's extension of reciprocal rights to Filipinos:

- (k) Copy of Treaty, International or Executive Agreement; **or**
- (l) Certification from the relevant government office of their country stating that Filipinos are allowed to participate in government procurement activities for the same item or product.
- (m) Certification from the DTI if the Bidder claims preference as a Domestic Bidder or Domestic Entity.
- (n)

Class "B" Documents

- (o) If applicable, a duly signed joint venture agreement (JVA) in case the joint venture is already in existence;
or
duly notarized statements from all the potential joint venture partners stating that they will enter into and abide by the provisions of the JVA in the instance that the bid is successful.



Financial Documents

- (p) The Supplier's audited financial statements, showing, among others, the Supplier's total and current assets and liabilities, stamped "received" by the BIR or its duly accredited and authorized institutions, for the preceding calendar year which should not be earlier than two (2) years from the date of bid submission; **and**
- (q) The prospective bidder's computation of Net Financial Contracting Capacity (NFCC);
or
A committed Line of Credit from a Universal or Commercial Bank in lieu of its NFCC computation.

II. FINANCIAL COMPONENT ENVELOPE

- (r) Original of duly signed and accomplished Financial Bid Form; **and**
- (s) Original of duly signed and accomplished Price Schedule(s)/Bid Breakdown.

IMPORTANT REMINDERS

- A) Each and every page of the **Bid Forms/Price Schedule(s)/Bid Breakdown**, under Section VIII: Checklist of Technical and Financial Documents hereof, shall be signed by the duly authorized representative/s of the Bidder. Failure to do so shall be a ground for the rejection of the bid.
- B) Any interlineations, erasures, or overwriting shall be valid only if they are signed or initialed by the duly authorized representative/s of the Bidder.
- C) Bid documents shall be compiled in a folder/binder with the Annexes properly labeled with tabs/separators.
- D) Bidders shall submit their bids through their duly authorized representative enclosed in separate sealed envelopes, which shall be submitted simultaneously:
- a) The first three individually sealed envelopes shall contain the folder/binder of the Eligibility Requirements and Technical Component of the bid; prepared in three copies labeled as follows:
- Envelop (1): ORIGINAL – Eligibility Requirements and Technical Component
Envelop (2): COPY1 – Eligibility Requirements and Technical Component
Envelop (3): COPY2 – Eligibility Requirements and Technical Component
- b) The next three individually sealed envelopes shall contain the folder/binder of the Financial Component of the bid; prepared in three copies labeled as follows:
- Envelop (4): ORIGINAL – Financial Component
Envelop (5): COPY1 – Financial Component
Envelop (6): COPY2 – Financial Component
- c) Bidders shall enclose, seal and mark the following:
- Envelop (7): Envelope (1) and Envelope (4) enclosed in one sealed envelope marked "ORIGINAL-BID"
- Envelop (8): Envelope (2) and Envelope (5) enclosed in one sealed envelope marked "COPY1-BID"



Envelop (9): Envelope (3) and Envelope (6) enclosed in one sealed envelope marked "COPY2-BID"

- d) Envelopes (7) to (9) shall then be enclosed in a single sealed, signed final/outerenvelope/package/box
- e) All envelopes (Envelopes (1) to (9) and the final/outer envelope/package/box) shall indicate the following:
- addressed to the Procuring Entity's BAC
 - name and address of the Bidder in capital letters
 - name of the contract/project to be bid in capital letters
 - bear the specific identification/reference code of this bidding process
 - bear a warning "DO NOT OPEN BEFORE..." the date and time for the opening of bids

<p>THE CHAIRPERSON BIDS AND AWARDS COMMITTEE 2ND FLOOR, SSS MAIN BUILDING EAST AVENUE, DILIMAN, QUEZON CITY</p> <p>NAME OF BIDDER : _____ ADDRESS : _____</p> <p>NAME OF PROJECT: _____ ITB REFERENCE NUMBER: _____</p> <p style="text-align: center;">DO NOT OPEN BEFORE (the date and time for the opening of bids)</p>

- E) Bids submitted after the deadline shall only be marked for recording purpose, shall not be included in the opening of bids, and shall be returned to the bidder unopened.
- F) Bidders shall submit a copy of the Authority to Notarize issued by the Regional Trial Court to the Notarial Public.



FORMS



Bid Form for the Procurement of Goods

BID FORM

MODULAR FURNITURE FOR CCD, MAD AND OVP PASED

Date: _____

Project Identification No.: _____

To: **SOCIAL SECURITY SYSTEM**
East Avenue, Diliman, Quezon City

Having examined the Philippine Bidding Documents (PBDs) including the Supplemental or Bid Bulletin Numbers [insert numbers], the receipt of which is hereby duly acknowledged, we, the undersigned, offer to Modular Furniture for CCD, MAD and OVP PASED in conformity with the said PBDs for the sum of **[total Bid amount in words and figures]** or the total calculated bid price, as evaluated and corrected for computational errors, and other bid modifications in accordance with the Price Schedules/Bid Breakdown attached herewith and made part of this Bid. The total bid price includes the cost of all taxes, such as, but not limited to: [specify the applicable taxes, e.g. (i) value added tax (VAT), (ii) income tax, (iii) local taxes, and (iv) other fiscal levies and duties], which are itemized herein or in the Price Schedules/Bid Breakdown,

If our Bid is accepted, we undertake:

- a. to deliver the goods in accordance with the delivery schedule specified in the Schedule of Requirements of the Philippine Bidding Documents (PBDs);
- b. to provide a performance security in the form, amounts, and within the times prescribed in the PBDs;
- c. to abide by the Bid Validity Period specified in the PBDs and it shall remain binding upon us at any time before the expiration of that period.

[Insert this paragraph if Foreign-Assisted Project with the Development Partner:

Commissions or gratuities, if any, paid or to be paid by us to agents relating to this Bid, and to contract execution if we are awarded the contract, are listed below:

Name and address of agent	Amount and Currency	Purpose of Commission or gratuity
_____	_____	_____
_____	_____	_____
_____	_____	_____

(if none, state "None")

Until a formal Contract is prepared and executed, this Bid, together with your written acceptance thereof and your Notice of Award, shall be binding upon us.

We understand that you are not bound to accept the Lowest Calculated Bid or any Bid you may receive.

We certify/confirm that we comply with the eligibility requirements pursuant to the PBDs.

The undersigned is authorized to submit the bid on behalf of [name of the bidder] as evidenced by the attached [state the written authority].

We acknowledge that failure to sign each and every page of this Bid Form, including the attached Schedule of Prices/Bid Breakdown, shall be a ground for the rejection of our bid.

Name: _____

Legal capacity: _____

Signature: _____

Duly authorized to sign the Bid for and behalf of: _____

Date: _____



FORM-02

Price Schedule(s)/Bid Breakdown

Name of Bidder _____

Invitation to Bid Number _____

ITEM	DESCRIPTION	QTY	UNIT	UNIT COST	TOTAL COST
I	MODULAR OFFICE SYSTEMS				
A	Division Head Workstation	1	set		
B	Department Manager Workstation	2	sets		
C	1-Seater Section Head Workstation	4	sets		
D	2-Seater Section Head Workstation	1	set		
E	1-Seater Staff/Nonsupervisor's Workstation 1	1	set		
F	1-Seater Staff/Nonsupervisor's Workstation 1	2	sets		
G	2-Seater Staff/Nonsupervisor's Workstation 1 (Back to Back)	1	set		
H	3-Seater Staff/Nonsupervisor's Workstation 1	2	sets		
I	8-Seater Staff/Nonsupervisor's Workstation 1	1	set		
J	3-Seater Staff/Nonsupervisor's Workstation 1a	1	set		
K	1-Seater Staff/Nonsupervisor's Workstation 2	1	set		
L	2-Seater Staff/Nonsupervisor's Workstation 2	3	sets		
M	3-Seater Staff/Nonsupervisor's Workstation 2	1	set		
N	6-Seater Staff/Nonsupervisor's Workstation 2	1	set		
O	7-Seater Staff/Nonsupervisor's Workstation 2	1	set		
P	8-Seater Staff/Nonsupervisor's Workstation 2	2	sets		
Q	1-Seater Staff/Nonsupervisor's Workstation 3	1	set		
R	Desks and Tables:	1	pc		
	Free Standing Computer Table	4	pcs		
	Meeting Table	2	pcs		
	Foldable Free Standing Table				
	TOTAL COST - MODULAR OFFICE SYSTEMS				
II	SEATING FURNITURE				
1	Executive Chair, High Back	3	units		
2	Supervisor's Chair, Mid Back w/ Armrest	5	units		
3	Non-Supervisor's Chair/Staff Chair, Low Back w/ Armrest	63	units		
4	Non-Supervisor's Chair/Conference Chair, 1-piece, Low Back w/o Armrest	20	units		
5	Guest Chair 1, Midback, Cantilever Type (For Executive) w/ Armrest	6	units		
6	Guest Chair 2, Lowback with Sled base w/ Armrest, with foam cushion	3	units		
7	Stackable Chair	6	units		
	TOTAL COST - SEATING FURNITURE				
III	CONTRACT FURNITURE				
1	Manager's Back Cabinet	3	units		
	TOTAL COST - CONTRACT FURNITURE				
IV	STEEL SHELVES, CABINETS & DRAWERS				
1	Mobile Pedestal Drawer	71	pcs		
2	4 Drawer Lateral Filing Cabinet	3	units		
	TOTAL COST - STEEL SHELVES, CABINETS & DRAWERS				
TOTAL COST					



Note:

1. Any bid exceeding the ABC of ₱ 2,669,638.72 shall not be accepted.
2. Fill up all required items/field in the bid breakdown. Failure to indicate any of the following shall mean outright disqualification since bid is considered Non-Responsive.
 - If the item is given for free, indicate dash (-), zero (0) or free
 - If the item is not applicable, indicate N/A
3. Please use the softcopy of the Bid Breakdown provided to the bidders.
4. All documents shall be signed, and each and every page thereof shall be initialed, by the duly authorized representative/s of the Bidder.
5. Bid proposal must be inclusive of all applicable taxes.
6. Warranty requirement is at no cost to SSS.

Name: _____

Legal capacity: _____

Signature: _____

Duly authorized to sign the Bid for and behalf of: _____



Formula in the Computation of NFCC

NAME OF PROJECT

NAME OF COMPANY

NFCC = 15 (Current Assets – Current Liabilities) – Value of All Outstanding Works under On-going Contracts including Awarded Contracts yet to be started)

YEAR	CURRENT ASSETS	CURRENT LIABILITIES
TOTAL		

Value of Outstanding Works under On-going Contracts:

CONTRACT DESCRIPTION	TOTAL CONTRACT AMOUNT AT AWARD	PERCENTAGE OF PLANNED AND ACTUAL ACCOMPLISHMENT	ESTIMATED COMPLETION TIME
TOTAL			

Use additional sheet/s, if necessary

FORMULA:

$$15 \times \left(\frac{\text{Current Assets} - \text{Current Liabilities}}{\text{Total Outstanding Works}} \right) = \text{NFCC}$$

$\frac{P}{\text{NFCC}}$

Prepared and Submitted by:

Signature over Printed Name



(Name of Bank)

COMMITTED LINE OF CREDIT CERTIFICATE

Date: _____

Social Security System (SSS)
SSS Main Building, East Avenue
Diliman, Quezon City

CONTRACT PROJECT	:	_____
COMPANY/FIRM	:	_____
ADDRESS	:	_____
BANK/FINANCING	:	_____
INSTITUTION	:	_____
ADDRESS	:	_____
AMOUNT	:	_____

This is to certify that the above Bank/Financing Institution with business address indicated above, commits to provide the (Supplier/Distributor/Manufacturer/Contractor), if awarded the above-mentioned Contract, a credit line in the amount specified above which shall be exclusively used to finance the performance of the above-mentioned contract subject to our terms, conditions and requirements.

The credit line shall be available within fifteen (15) calendar days after receipt by the (Supplier/Distributor/Manufacturer/Contractor) of the Notice of Award and such line of credit shall be maintained until issuance of Certificate of Acceptance by the Social Security System.

This Certification is being issued in favor of said (Supplier/Distributor/Manufacturer/Contractor) in connection with the bidding requirement of (Name of Procuring Entity) for the above-mentioned Contract. We are aware that any false statements issued by us make us liable for perjury.

The committed line of credit cannot be terminated or cancelled without the prior written approval of Social Security System.

Name and Signature of Authorized Financing Institution Office

Office Designation

Concurred by:

Name & Signature of (Supplier/Distributor/Manufacturer/Contractor) Authorized Representative

Official Designation

SUBSCRIBED AND SWORN TO BEFORE ME this _____ day of _____ at _____ Philippines, Affiant exhibited to me his/her competent Evidence of Identity (as defines by the 2004 Rules on Notarial Practice _____ issued on _____ at _____, Philippines.

NOTARY PUBLIC

Doc No.	:	_____
Page No.	:	_____
Book No.	:	_____
Series of	:	_____

(Note: The amount committed should be machine validated in the Certificate itself)



FORM-05

STATEMENT OF ON-GOING GOVERNMENT AND PRIVATE CONTRACTS

NAME OF CONTRACT	DATE OF CONTRACT	CONTRACT DURATION	CONTACT PERSON, CONTACT NO., ADDRESS, AND EMAIL ADDRESS	KINDS OF GOODS	AMOUNT OF CONTRACT	VALUE OF OUTSTANDING CONTRACT / PERCENTAGE OF COMPLETION



FORM-06

STATEMENT OF SINGLE LARGEST COMPLETED CONTRACT SIMILAR TO THE PROJECT TO BE BID EQUIVALENT TO AT LEAST 50% OF THE ABC WITH ATTACHED SUPPORTING DOCUMENTS (i.e. P.O/CONTRACT)

NAME OF CONTRACT	KINDS OF GOODS	AMOUNT OF CONTRACT	CONTACT PERSON, CONTACT NO., ADDRESS, AND EMAIL ADDRESS



Bid Securing Declaration Form

REPUBLIC OF THE PHILIPPINES) CITY
OF _____) S.S.

BID SECURING DECLARATION

Project Identification No.: [Insert number]

To: *[Insert name and address of the Procuring Entity]*

I/We, the undersigned, declare that:

1. I/We understand that, according to your conditions, bids must be supported by a Bid Security, which may be in the form of a Bid Securing Declaration.
2. I/We accept that: (a) I/we will be automatically disqualified from bidding for any procurement contract with any procuring entity for a period of two (2) years upon receipt of your Blacklisting Order; and, (b) I/we will pay the applicable fine provided under Section 6 of the Guidelines on the Use of Bid Securing Declaration, within fifteen (15) days from receipt of the written demand by the procuring entity for the commission of acts resulting to the enforcement of the bid securing declaration under Sections 23.1(b), 34.2, 40.1 and 69.1, except 69.1(f), of the IRR of RA No. 9184; without prejudice to other legal action the government may undertake.
3. I/We understand that this Bid Securing Declaration shall cease to be valid on the following circumstances:
 - a. Upon expiration of the bid validity period, or any extension thereof pursuant to your request;
 - b. I am/we are declared ineligible or post-disqualified upon receipt of your notice to such effect, and (i) I/we failed to timely file a request for reconsideration or (ii) I/we filed a waiver to avail of said right; and
 - c. I am/we are declared the bidder with the Lowest Calculated Responsive Bid, and I/we have furnished the performance security and signed the Contract.

IN WITNESS WHEREOF, I/We have hereunto set my/our hand/s this ____ day of *[month]* *[year]* at *[place of execution]*.

[Insert NAME OF BIDDER OR ITS AUTHORIZED REPRESENTATIVE]

[Insert signatory's legal capacity]

Affiant

[Jurat]

[Format shall be based on the latest Rules on Notarial Practice]

GPPB Resolution No. 16-2020, dated 16 September 2020



**Contract Agreement Form for the
Procurement of Infrastructure Projects (Revised)**

*[Not required to be submitted with the Bid, but it shall be submitted within ten (10) days
after receiving the Notice of Award]*

**CONTRACT AGREEMENT
Modular Furniture for CCD, MAD and OVP PASED**

THIS AGREEMENT made the _____ day of _____ 20____ between [name and address of PROCURING ENTITY] of the Philippines (hereinafter called “the Entity”) and [name and address of Contractor] (hereinafter called the “Contractor”).

WHEREAS, the Entity is desirous that the Contractor execute [name and identification number of contract] (hereinafter called “the Works”) and the Entity has accepted the Bid for [contract price in words and figures in specified currency] by the Contractor for the execution and completion of such Works and the remedying of any defects therein.

NOW THIS AGREEMENT WITNESSETH AS FOLLOWS:

1. In this Agreement words and expressions shall have the same meanings as are respectively assigned to them in the Conditions of Contract referred to.
2. The following documents as required by the 2016 revised Implementing Rules and Regulations of Republic Act No. 9184 shall be deemed to form and be read and construed as integral part of this Agreement, *viz.*:
 - a. Philippine Bidding Documents (PBDs);
 - i. Drawings/Plans;
 - ii. Specifications;
 - iii. Bill of Quantities;
 - iv. General and Special Conditions of Contract;
 - v. Supplemental or Bid Bulletins, if any

- b. Winning bidder’s bid, including the Eligibility requirements, Technical and Financial Proposals, and all other documents or statements submitted;

Bid form, including all the documents/statements contained in the Bidder’s bidding envelopes, as annexes, and all other documents submitted (*e.g.*, Bidder’s response to request for clarifications on the bid), including corrections to the bid, if any, resulting from the Procuring Entity’s bid evaluation;

- c. Performance Security;

- d. Notice of Award of Contract; and the Bidder’s conforme thereto; and



- e. Other contract documents that may be required by existing laws and/or the Procuring Entity concerned in the PBDs. **Winning bidder agrees that additional contract documents or information prescribed by the GPPB that are subsequently required for submission after the contract execution, such as the Notice to Proceed, Variation Orders, and Warranty Security, shall likewise form part of the Contract.**
3. In consideration for the sum of *[total contract price in words and figures]* or such other sums as may be ascertained, *[Named of the bidder]* agrees to *[state the object of the contract]* in accordance with his/her/its Bid.
4. The *[Name of the procuring entity]* agrees to pay the above-mentioned sum in accordance with the terms of the Bidding.

IN WITNESS whereof the parties hereto have caused this Agreement to be executed in accordance with the laws of the Republic of the Philippines on the day and year first above written.

<i>[Insert Name and Signature]</i>	<i>[Insert Name and Signature]</i>
<i>[Insert Signatory's Legal Capacity]</i>	<i>[Insert Signatory's Legal Capacity]</i>
<i>for:</i>	<i>for:</i>
<i>[Insert Procuring Entity]</i>	<i>[Insert Name of Supplier]</i>

Acknowledgment

[Format shall be based on the latest Rules on Notarial Practice]

GPPB Resolution No. 16-2020, dated 16 September 2020

Omnibus Sworn Statement (Revised)

REPUBLIC OF THE PHILIPPINES)
CITY/MUNICIPALITY OF _____) S.S.

AFFIDAVIT

I, *[Name of Affiant]*, of legal age, *[Civil Status]*, *[Nationality]*, and residing at *[Address of Affiant]*, after having been duly sworn in accordance with law, do hereby depose and state that:

1. **Select one, delete the other:**

[If a sole proprietorship:] I am the sole proprietor or authorized representative of *[Name of Bidder]* with office address at *[address of Bidder]*;

[If a partnership, corporation, cooperative, or joint venture:] I am the duly authorized and designated representative of *[Name of Bidder]* with office address at *[address of Bidder]*;

2. **Select one, delete the other:**

[If a sole proprietorship:] As the owner and sole proprietor, or authorized representative of *[Name of Bidder]*, I have full power and authority to do, execute and perform any and all acts necessary to participate, submit the bid, and to sign and execute the ensuing contract for *[Name of the Project]* of the *[Name of the Procuring Entity]* as shown in the attached duly notarized Special Power of Attorney;

[If a partnership, corporation, cooperative, or joint venture:] I am granted full power and authority to do, execute and perform any and all acts necessary to participate, submit the bid, and to sign and execute the ensuing contract for *[Name of the Project]* of the *[Name of the Procuring Entity]*, as shown in the attached [state title of attached documents showing proof of authorization (e.g., duly notarized Secretary's Certificate, Board/Partnership Resolution, or Special Power of Attorney, whichever is applicable;)];

3. *[Name of Bidder]* is not "blacklisted" or barred from bidding by the Government of the Philippines or any of its agencies, offices, corporations, or Local Government Units, foreign government/foreign or international financing institution whose blacklisting rules have been recognized by the Government Procurement Policy Board, **by itself or by relation, membership, association, affiliation, or controlling interest with another blacklisted person or entity as defined and provided for in the Uniform Guidelines on Blacklisting;**

4. Each of the documents submitted in satisfaction of the bidding requirements is an authentic copy of the original, complete, and all statements and information provided therein are true and correct;

5. *[Name of Bidder]* is authorizing the Head of the Procuring Entity or its duly authorized representative(s) to verify all the documents submitted;6. **Select one, delete the rest:**

[If a sole proprietorship:] The owner or sole proprietor is not related to the Head of the Procuring Entity, members of the Bids and Awards Committee (BAC), the Technical Working Group, and the BAC Secretariat, the head of the Project Management Office or the end-user unit, and the project consultants by consanguinity or affinity up to the third civil degree;

[If a partnership or cooperative:] None of the officers and members of *[Name of Bidder]* is related to the Head of the Procuring Entity, members of the Bids and Awards Committee (BAC), the Technical Working Group, and the BAC Secretariat, the head of the Project Management Office or the end-user unit, and the project consultants by consanguinity or affinity up to the third civil degree;

[If a corporation or joint venture:] None of the officers, directors, and controlling stockholders of *[Name of Bidder]* is related to the Head of the Procuring Entity, members of the Bids and Awards Committee (BAC), the Technical Working Group, and the BAC Secretariat, the head of the Project Management Office or the end-user unit, and the project consultants by consanguinity or affinity up to the third civil degree;

7. *[Name of Bidder]* complies with existing labor laws and standards; and
8. *[Name of Bidder]* is aware of and has undertaken the responsibilities as a Bidder in compliance with the Philippine Bidding Documents, which includes:
 - a) Carefully examining all of the Bidding Documents;
 - b) Acknowledging all conditions, local or otherwise, affecting the implementation of the Contract;
 - c) Making an estimate of the facilities available and needed for the contract to be bid, if any; and
 - d) Inquiring or securing Supplemental/Bid Bulletin(s) issued for the *[Name of the Project]*.
9. *[Consultant]* did not give or pay directly or indirectly, any commission, amount, fee, or any form of consideration, pecuniary or otherwise, to any person or official, personnel or representative of the government in relation to any procurement project or activity.
10. **In case advance payment was made or given, failure to perform or deliver any of the obligations and undertakings in the contract shall be sufficient grounds to constitute criminal liability for Swindling (Estafa) or the commission of fraud with unfaithfulness or abuse of confidence through misappropriating or converting any payment received by a person or entity under an obligation involving the duty to deliver certain goods or services, to the prejudice of the public and the government of the Philippines pursuant to Article 315 of Act No. 3815 s.1930, as amended, or the Revised Penal Code.**

IN WITNESS WHEREOF, I have hereunto set my hand this ___ day of ___, 20__ at _____, Philippines.

[Insert NAME OF BIDDER OR ITS AUTHORIZED REPRESENTATIVE]

[Insert signatory's legal capacity]

Affiant

[Jurat]

[Format shall be based on the latest Rules on Notarial Practice]

GPPB Resolution No. 16-2020, dated 16 September 2020



Performance Securing Declaration (Revised)

[As alternative performance security to be submitted by the winning bidder within ten (10) days from receipt of Notice of Award]

REPUBLIC OF THE PHILIPPINES)

CITY OF _____) S.S.

PERFORMANCE SECURING DECLARATION

Invitation to Bid: [Insert Reference Number indicated in the Bidding Documents] To: [Insert name and address of the Procuring Entity]

I/We, the undersigned, declare that:

1. I/We understand that, according to your conditions, to guarantee the faithful performance by the supplier/distributor/manufacturer/contractor/consultant of its obligations under the Contract, I/we shall submit a Performance Securing Declaration within a maximum period of ten (10) calendar days from the receipt of the Notice of Award prior to the signing of the Contract.
2. I/We accept that: I/we will be automatically disqualified from bidding for any procurement contract with any procuring entity for a period of one (1) year for the first offense, or two (2) years **for the second offense**, upon receipt of your Blacklisting Order if I/We have violated my/our obligations under the Contract;
3. I/We understand that this Performance Securing Declaration shall cease to be valid upon:
 - a. issuance by the Procuring Entity of the Certificate of Final Acceptance, subject to the following conditions:
 - i. Procuring Entity has no claims filed against the contract awardee;
 - ii. It has no claims for labor and materials filed against the contractor; and
 - iii. Other terms of the contract; or
 - b. replacement by the winning bidder of the submitted PSD with a performance security in any of the prescribed forms under Section 39.2 of the 2016 revised IRR of RA No. 9184 as required by the end-user.

IN WITNESS WHEREOF, I/We have hereunto set my/our hand/s this ____ day of [month] [year] at [place of execution].

*[Insert NAME OF BIDDER OR ITS
AUTHORIZED REPRESENTATIVE]*
[Insert signatory's legal capacity]
Affiant

[Jurat]

[Format shall be based on the latest Rules on Notarial Practice]



ANNEX 1: PHOTOS

I. MODULAR OFFICE SYSTEM

A. DIVISION HEAD WORKSTATION



B. DEPARTMENT MANAGER WORKSTATION



C. 1-SEATER SECTION HEAD WORKSTATION

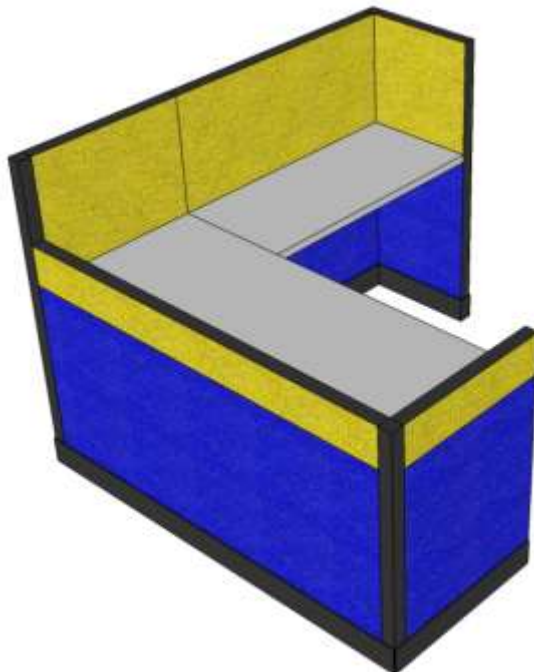

D. 2-SEATER SECTION HEAD WORKSTATION

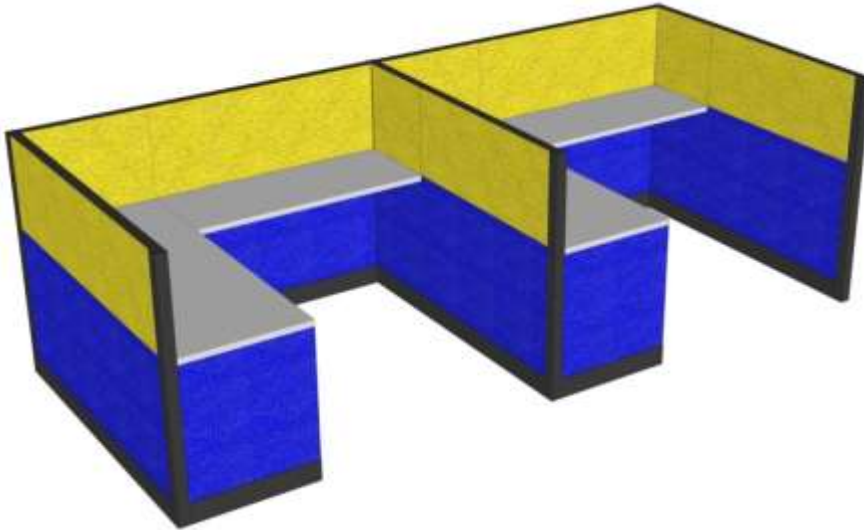

E. 1-SEATER STAFF/NONSUPERVISOR'S WORKSTATION

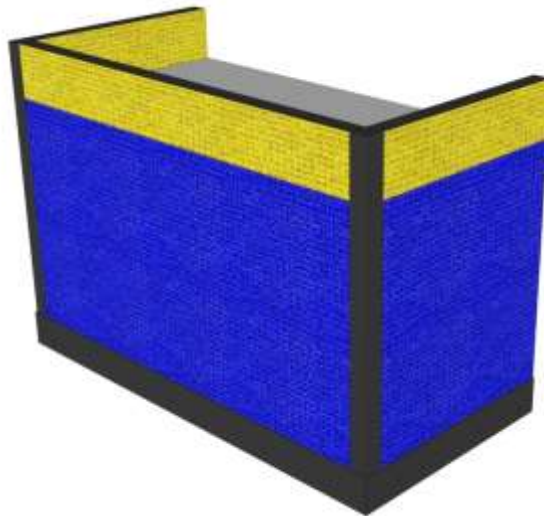

F. 1-SEATER STAFF/NONSUPERVISOR'S WORKSTATION 1
(High Partition with quarter glass panel)

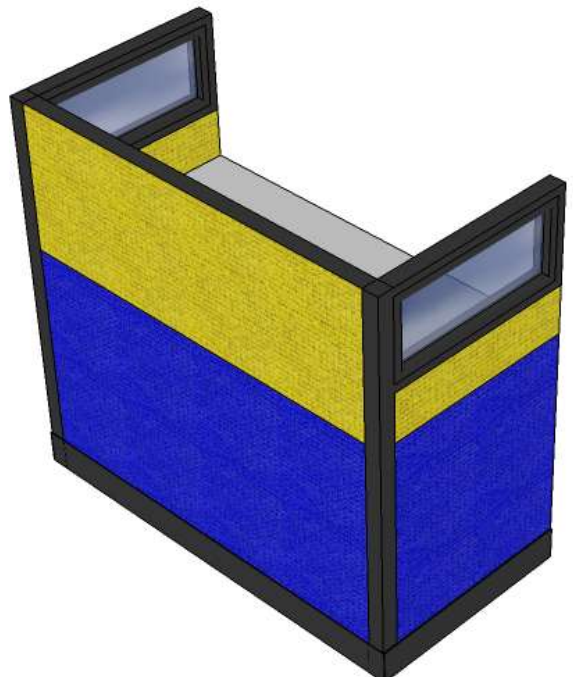

G. 2-SEATER STAFF/NONSUPERVISOR'S WORKSTATION 1
(Back to back w/ High Partition with quarter glass panel)

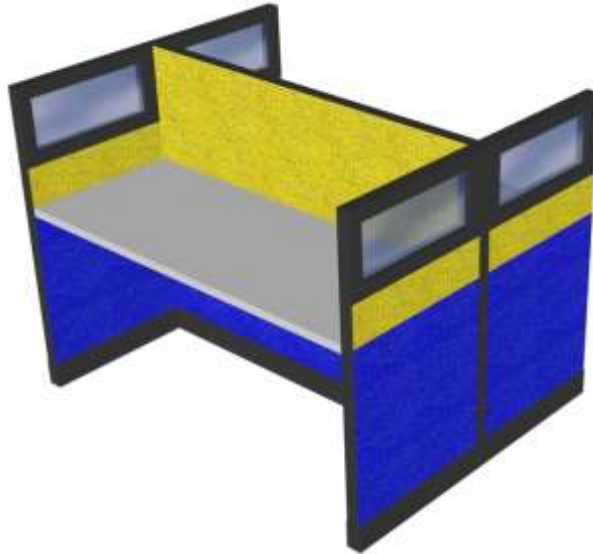

H. 3-SEATER STAFF/NONSUPERVISOR'S WORKSTATION 1
(High Partition with quarter glass panel)

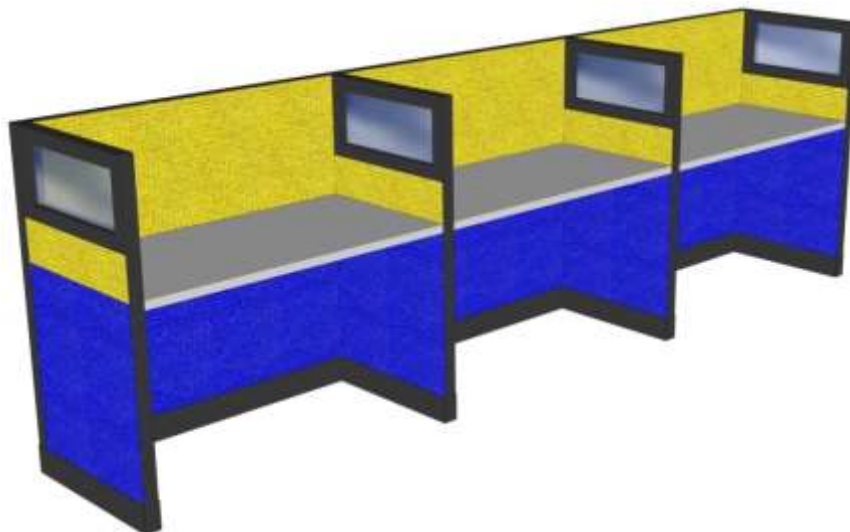

I. 8 SEATER STAFF/NONSUPERVISOR'S WORKSTATION
(High Partition with quarter glass panel)

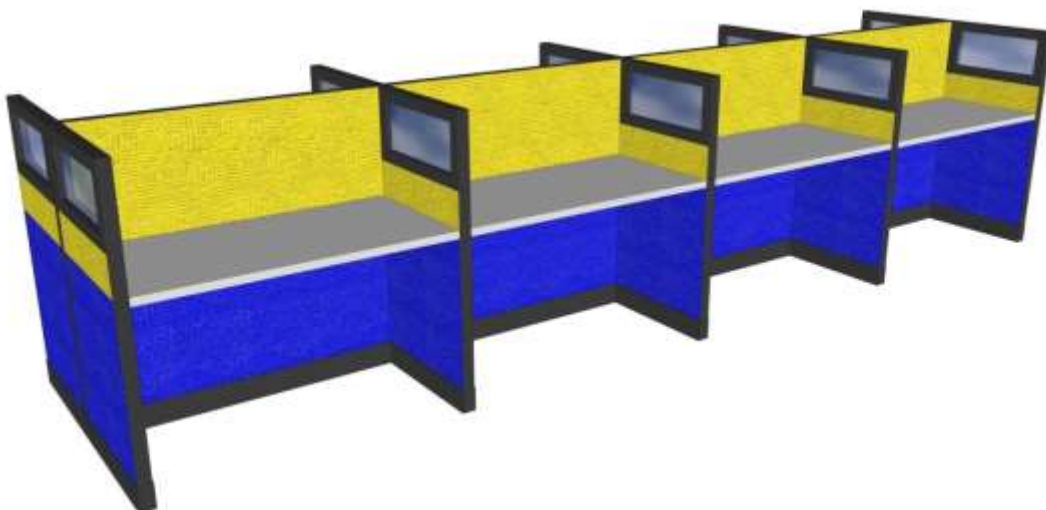

J. 3 SEATER STAFF/NONSUPERVISOR'S WORKSTATION (Irregular Shape)

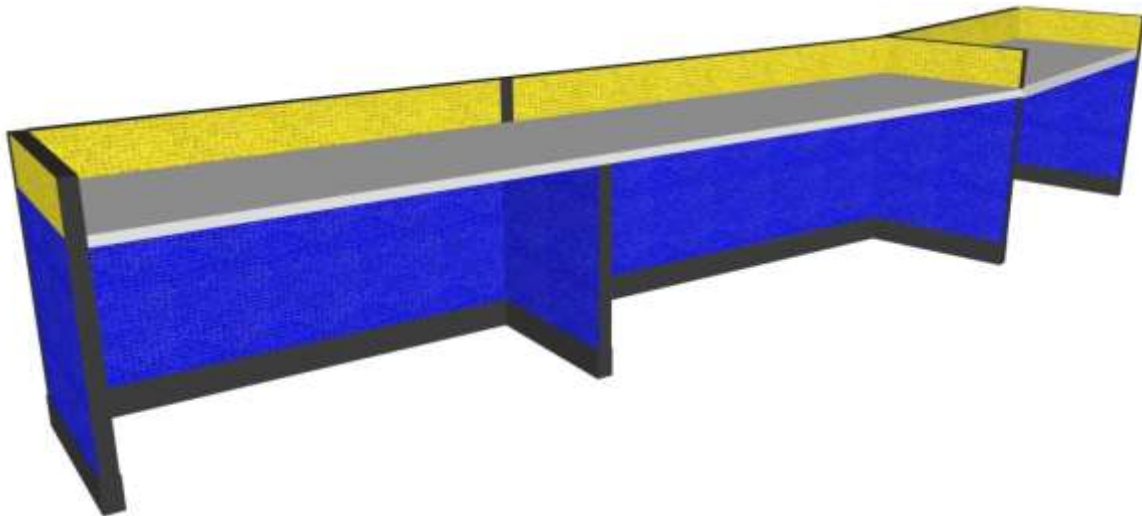
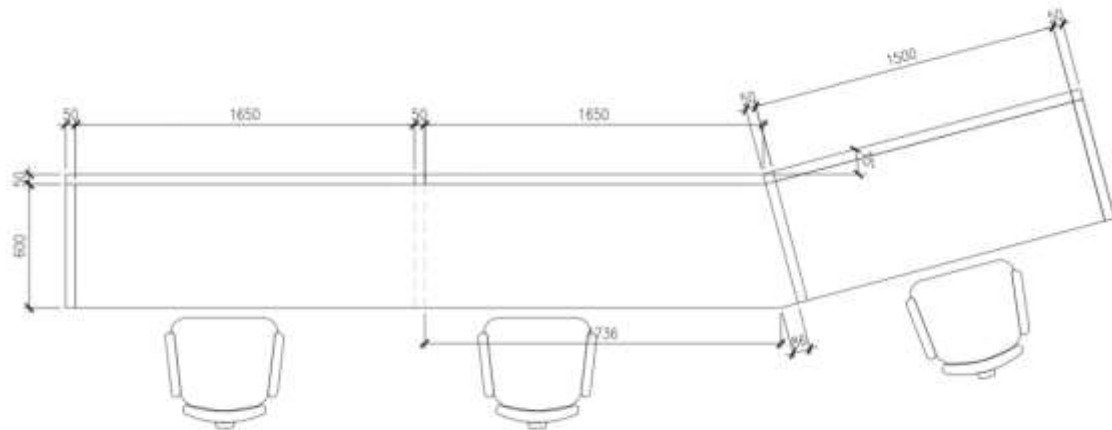

K. 1-SEATER STAFF/NONSUPERVISOR'S WORKSTATION 2
(High Partition with quarter glass panel)

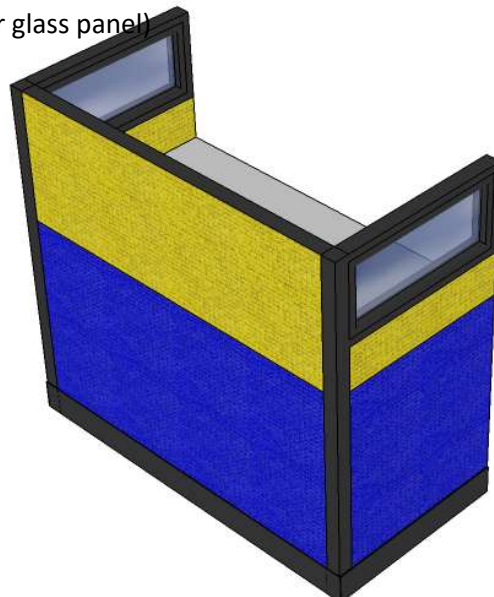

L. 2-SEATER STAFF/NONSUPERVISOR'S WORKSTATION 2
(High Partition with quarter glass panel)

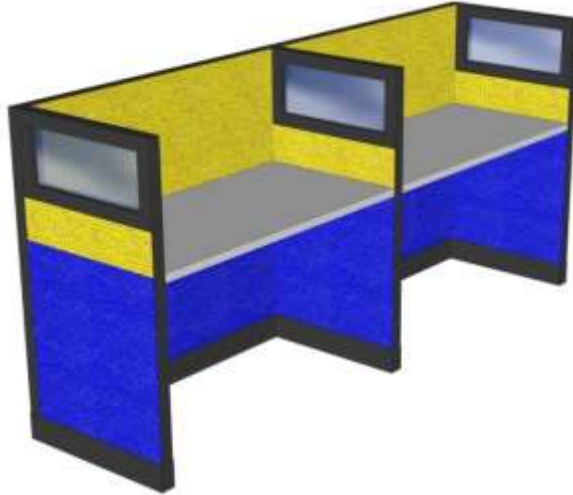

M. 3-SEATER STAFF/NONSUPERVISOR'S WORKSTATION 2
(High Partition with quarter glass panel)

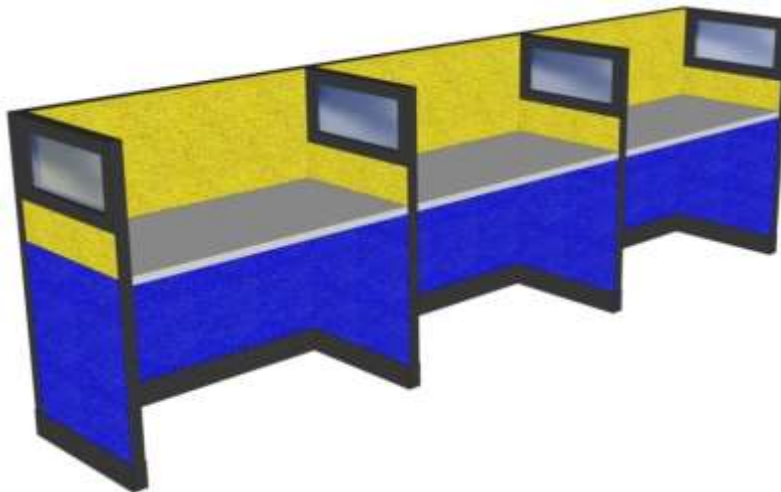

N. 6-SEATER STAFF/NONSUPERVISOR'S WORKSTATION 2
(High Partition with quarter glass panel)

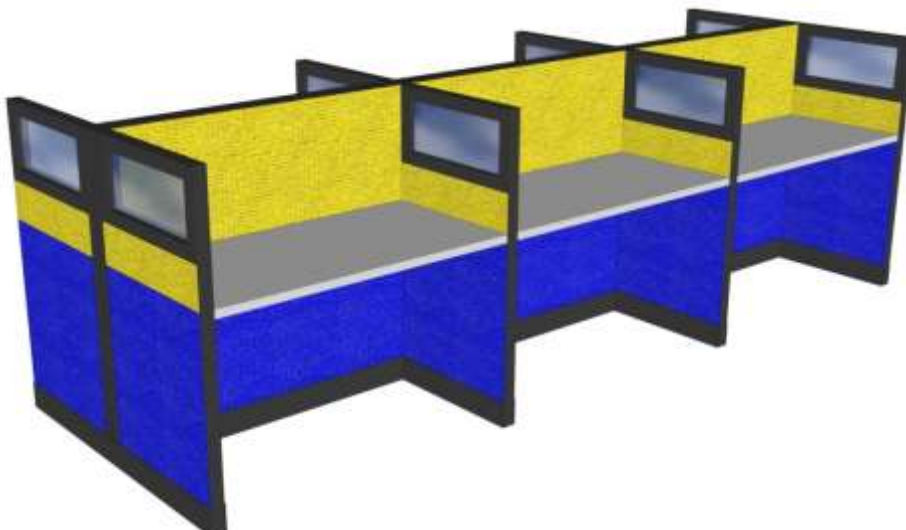

O. 7-SEATER STAFF/NONSUPERVISOR'S WORKSTATION 2
P. 8-SEATER STAFF/NONSUPERVISOR'S WORKSTATION 2

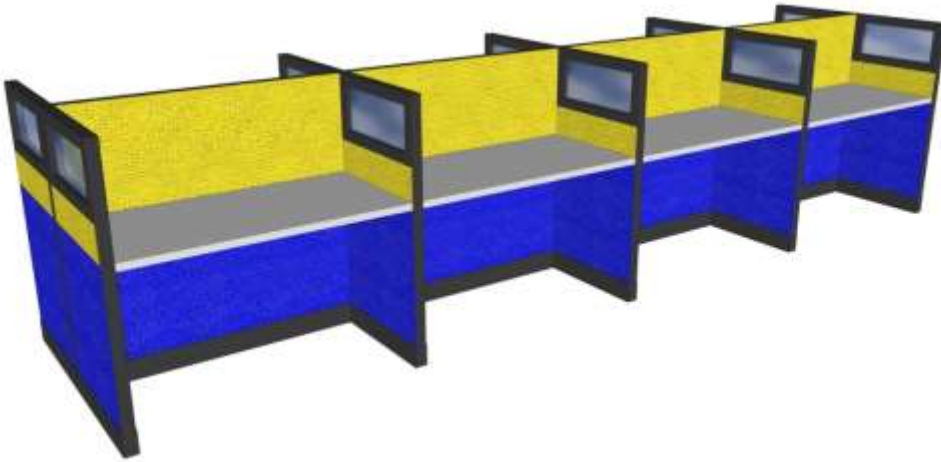

Q. 1-SEATER STAFF/NONSUPERVISOR'S WORKSTATION

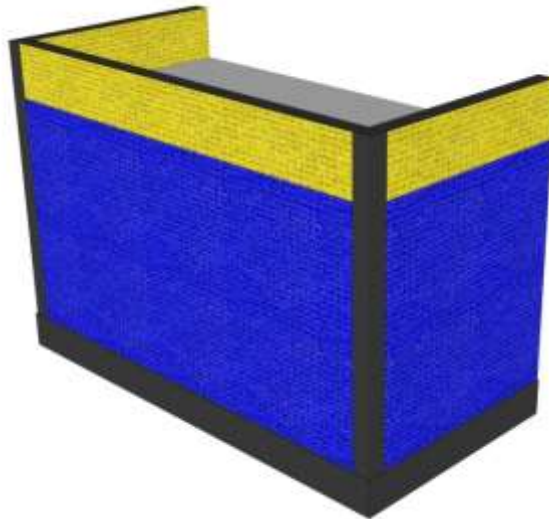

R. DESKS AND TABLES

R.1 FREE-STANDING COMPUTER TABLE – (FS1)



R.2 ROUND/MEETING TABLE
(Manager's Office and Pantry)



R.3 CONFERENCE FOLDABLE FREE STANDING TABLE
(Second Floor)



II. SEATING FURNITURE

EXECUTIVE CHAIR - (S1)



SUPERVISOR'S CHAIR - (S2)



NON SUPERVISOR'S CLERICAL CHAIR (S3)



NON SUPERVISOR'S CLERICAL/CONFERENCE/MEETING TABLE CHAIR - (S4)



GUEST CHAIR 01 - (S5)
(FOR EXECUTIVE OFFICE)



GUEST CHAIR 2 - (S6)



STACKABLE CHAIR - (S7)



III. CONTRACT FURNITURE

MANAGER'S BACK CABINET - (MBC)



IV. STEEL SHELVES, CABINETS & DRAWERS



MOBILE PEDESTAL DRAWER



4-DRAWER LATERAL FILING CABINET



GENERAL SPECIFICATIONS

Hooks and brackets shall be provided with locking devices to prevent accidental dismounting of worktop when attached to the panels/supports. Panels that are perpendicular or parallel to a fix wall shall be anchored to the wall using metal connectors, otherwise all assemblies shall be properly anchored to the floor.

Modular panels shall be fully interchangeable and can be dismantled or assembled without the use of special tools.

Panels and worktops with thickness that are not commercially available shall be fabricated using the same material, laminated together using appropriate adhesives and applicable technology.

Materials or accessories deemed necessary to complete the modular workstations but not specifically mentioned in the Specifications, Bid Breakdown Form, working drawings or in the other contract documents are inferred and shall be supplied, installed and rendered by the contractor without extra cost to the owner. Such material shall be of the highest quality available and installed in an appropriate manner.

ANNEX 2: PLANS/DRAWINGS

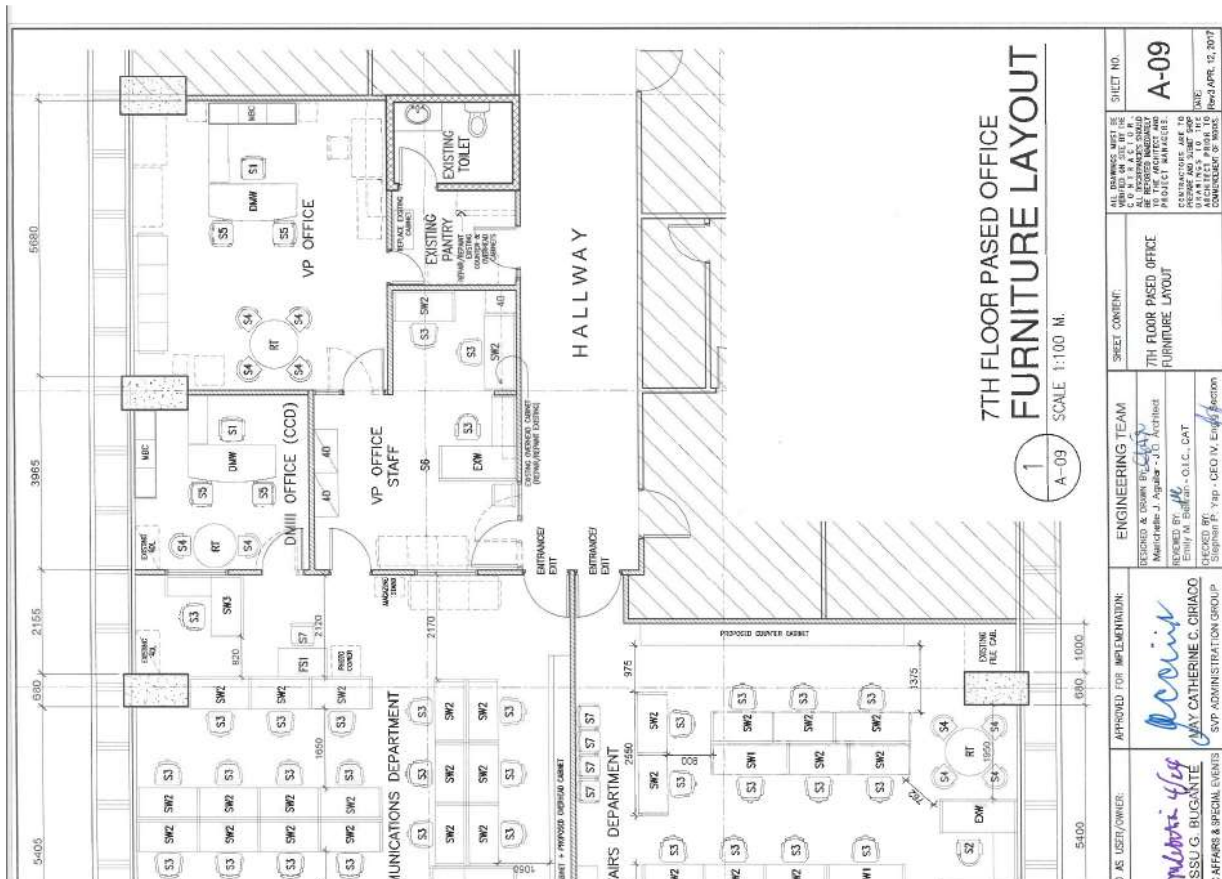

6

