



SOCIAL SECURITY SYSTEM

PHILIPPINE BIDDING DOCUMENTS

Sixth Edition

Procurement of INFRASTRUCTURE PROJECTS

Government of the Republic of the Philippines

**RENOVATION OF 4TH FLOOR
(COA, RIMT RECORDS ROOM, NETWORK
ROOM AND STORAGE ROOM) AND
VARIOUS IMPROVEMENTS AT GROUND
FLOOR (INFO KIOSK, ELECTRICAL
ROOM AND VAULT ROOM) AT SSS
BAGUIO BUILDING**

ITB-SSS-CIVIL-2022-002

JUNE 2022

Marichelle J. Aguilar
TWG Chairperson

TABLE OF CONTENTS

GLOSSARY OF.....	4
TERMS, ABBREVIATIONS, AND ACRONYMS	4
SECTION I. INVITATION TO BID.....	6
SECTION II. INSTRUCTIONS TO BIDDERS	9
1. Scope of Bid.....	10
2. Funding Information	10
3. Bidding Requirements.....	10
4. Corrupt, Fraudulent, Collusive, Coercive, and Obstructive Practices	11
5. Eligible Bidders.....	11
6. Origin of Associated Goods	11
7. Subcontracts	11
8. Pre-Bid Conference	11
9. Clarification and Amendment of Bidding Documents.....	11
10. Documents Comprising the Bid: Eligibility and Technical Components	11
11. Documents Comprising the Bid: Financial Component	12
12. Alternative Bids	12
13. Bid Prices	12
14. Bid and Payment Currencies	12
15. Bid Security.....	12
16. Sealing and Marking of Bids.....	13
17. Deadline for Submission of Bids	13
18. Opening and Preliminary Examination of Bids	13
19. Detailed Evaluation and Comparison of Bids.....	13
20. Post Qualification.....	13
21. Signing of the Contract	13
SECTION III. BID DATA SHEET	14
SECTION IV. GENERAL CONDITIONS OF CONTRACT	17
1. Scope of Contract.....	18
2. Sectional Completion of Works	18
3. Possession of Site.....	18
4. The Contractor’s Obligations.....	18
5. Performance Security	18
6. Site Investigation Reports	19
7. Warranty.....	19
8. Liability of the Contractor.....	19
9. Termination for Other Causes	19
10. Dayworks	19
11. Program of Work.....	19



12. Instructions, Inspections and Audits	20
13. Advance Payment.....	20
14. Progress Payments	20
15. Operating and Maintenance Manuals.....	20
SECTION V. SPECIAL CONDITIONS OF CONTRACT	21
SECTION VI. SPECIFICATIONS.....	27
SECTION VII. DRAWINGS	42
SECTION VIII. BILL OF QUANTITIES	73
SECTION IX. CHECKLIST OF TECHNICAL AND FINANCIAL DOCUMENTS	82



Glossary of Terms, Abbreviations, and Acronyms

ABC – Approved Budget for the Contract.

ARCC – Allowable Range of Contract Cost.

BAC – Bids and Awards Committee.

Bid – A signed offer or proposal to undertake a contract submitted by a bidder in response to and in consonance with the requirements of the bidding documents. Also referred to as *Proposal* and *Tender*. (2016 revised IRR, Section 5[c])

Bidder – Refers to a contractor, manufacturer, supplier, distributor and/or consultant who submits a bid in response to the requirements of the Bidding Documents. (2016 revised IRR, Section 5[d])

Bidding Documents – The documents issued by the Procuring Entity as the bases for bids, furnishing all information necessary for a prospective bidder to prepare a bid for the Goods, Infrastructure Projects, and/or Consulting Services required by the Procuring Entity. (2016 revised IRR, Section 5[e])

BIR – Bureau of Internal Revenue.

BSP – Bangko Sentral ng Pilipinas.

CDA – Cooperative Development Authority.

Consulting Services – Refer to services for Infrastructure Projects and other types of projects or activities of the GOP requiring adequate external technical and professional expertise that are beyond the capability and/or capacity of the GOP to undertake such as, but not limited to: (i) advisory and review services; (ii) pre-investment or feasibility studies; (iii) design; (iv) construction supervision; (v) management and related services; and (vi) other technical services or special studies. (2016 revised IRR, Section 5[i])

Contract – Refers to the agreement entered into between the Procuring Entity and the Supplier or Manufacturer or Distributor or Service Provider for procurement of Goods and Services; Contractor for Procurement of Infrastructure Projects; or Consultant or Consulting Firm for Procurement of Consulting Services; as the case may be, as recorded in the Contract Form signed by the parties, including all attachments and appendices thereto and all documents incorporated by reference therein.

Contractor – is a natural or juridical entity whose proposal was accepted by the Procuring Entity and to whom the Contract to execute the Work was awarded. Contractor as used in these Bidding Documents may likewise refer to a supplier, distributor, manufacturer, or consultant.

CPI – Consumer Price Index.

DOLE – Department of Labor and Employment.

DTI – Department of Trade and Industry.

Foreign-funded Procurement or Foreign-Assisted Project – Refers to procurement whose funding source is from a foreign government, foreign or international financing institution as specified in the Treaty or International or Executive Agreement. (2016 revised IRR, Section 5[b]).

GFI – Government Financial Institution.

GOCC – Government-owned and/or –controlled corporation.

Goods – Refer to all items, supplies, materials and general support services, except Consulting Services and Infrastructure Projects, which may be needed in the transaction of public businesses or in the pursuit of any government undertaking, project or activity, whether in the nature of equipment, furniture, stationery, materials for construction, or personal property of any kind, including non-personal or contractual services such as the repair and maintenance of equipment and furniture, as well as trucking, hauling, janitorial, security, and related or analogous services, as well as procurement of materials and supplies provided by the Procuring Entity for such services. The term “related” or “analogous services” shall include, but is not limited to, lease or purchase of office space, media advertisements, health maintenance services, and other services essential to the operation of the Procuring Entity. (2016 revised IRR, Section 5[r])

GOP – Government of the Philippines.

Infrastructure Projects – Include the construction, improvement, rehabilitation, demolition, repair, restoration or maintenance of roads and bridges, railways, airports, seaports, communication facilities, civil works components of information technology projects, irrigation, flood control and drainage, water supply, sanitation, sewerage and solid waste management systems, shore protection, energy/power and electrification facilities, national buildings, school buildings, hospital buildings, and other related construction projects of the government. Also referred to as *civil works or works*. (2016 revised IRR, Section 5[u])

LGUs – Local Government Units.

NFCC – Net Financial Contracting Capacity.

NGA – National Government Agency.

PCAB – Philippine Contractors Accreditation Board.

PhilGEPS - Philippine Government Electronic Procurement System.

Procurement Project – refers to a specific or identified procurement covering goods, infrastructure project or consulting services. A Procurement Project shall be described, detailed, and scheduled in the Project Procurement Management Plan prepared by the agency which shall be consolidated in the procuring entity's Annual Procurement Plan. (GPPB Circular No. 06-2019 dated 17 July 2019)

PSA – Philippine Statistics Authority.

SEC – Securities and Exchange Commission.

SLCC – Single Largest Completed Contract.

SSS – Social Security System.

Supplier – refers to a citizen, or any corporate body or commercial company duly organized and registered under the laws where it is established, habitually established in business and engaged in the manufacture or sale of the merchandise or performance of the general services covered by his bid. (Item 3.8 of GPPB Resolution No. 13-2019, dated 23 May 2019). Supplier as used in these Bidding Documents may likewise refer to a distributor, manufacturer, contractor, or consultant.

UN – United Nations.

Section I. Invitation to Bid



REPUBLIC OF THE PHILIPPINES
SOCIAL SECURITY SYSTEM

East Avenue, Diliman, Quezon City
 Tel. Nos. (632)8709-7198 *(632)8920-6446

E-mail: member_relations@sss.gov.ph* Website <http://www.sss.gov.ph>

Invitation to Bid
ITB-SSS-Civil-2022-002

RENOVATION OF 4TH FLOOR (COA, RIMT RECORDS ROOM, NETWORK ROOM AND STORAGE ROOM) AND VARIOUS IMPROVEMENTS AT GROUND FLOOR (INFO KIOSK, ELECTRICAL ROOM AND VAULT ROOM) AT SSS BAGUIO BUILDING

Approved Budget for the Contract (ABC) & Source of Fund	Delivery/ Completion Period	Price of Bid Documents (non-refundable)	Schedule of Activities Date/Time	
			Pre-bid Conference	Deadline of submission and receipt of bids
<p>₱ 4,740,006.00</p> <p>Broken down as follows:</p> <p>Item 1: Renovation of 4th Floor at SSS Baguio (COA, RIMT, Records Room Area, Network Room and Storage Room) – ₱4,399,391.00 Code PAP No. 2022-134</p> <p>Item 2: Various Improvements at SSS Baguio (info kiosk, electrical room and vault at ground floor) – ₱340,615.00 Code PAP No. 2022-135</p> <p>2022 Corporate Operating Budget under MOOE of the 2022 Annual Procurement Plan</p>	<p>One Hundred Fifty (150) calendar days from the receipt of Notice to Proceed and Signed Contract/Job Order</p>	<p>₱5,000.00</p>	<p>July 13, 2022 (Wednesday) 2:30pm</p>	<p>August 03, 2022 (Wednesday) 2:00pm</p>

1. The **SOCIAL SECURITY SYSTEM (SSS)** now invites bids for the above Procurement Project. Completion of the **Works is required within the delivery/completion period indicated above. Bidders should have completed within five (5) years prior to the date of submission and receipt of bids, a contract similar to the Project.** The description of an eligible bidder is contained in the Bidding Documents, particularly, in Section II (Instructions to Bidders).
2. Bids received in excess of the ABC shall be automatically rejected at Bid opening.
3. Bidding will be conducted through open competitive bidding procedures using non-discretionary “*pass/fail*” criterion as specified in the 2016 revised Implementing Rules and Regulations (IRR) of Republic Act (RA) No. 9184.
4. Interested bidders may obtain further information from SSS and inspect the Bidding Documents at the address in the last item of the ITB from Monday to Friday, 8:00 a.m. to 5:00 p.m.
5. A complete set of Bidding Documents may be acquired by interested Bidders starting **04 July 2022 up to the scheduled submission & opening of bids** from the address stated in the last item of the ITB and upon payment of the applicable fee for the Bidding Documents, in the amount specified above.

The mode of payment will be on a cash basis payable at the SSS Cash Department, SSS Main Bldg., Ground floor, upon accomplishment of SSS Form R-6. The Bidding Documents shall be received personally by the prospective Bidder or his authorized representative.

It may also be downloaded free of charge from the website of the Philippine Government Electronic Procurement System (PhilGEPS) and the website of the SSS, provided that Bidders shall pay the applicable fee for the Bidding Documents not later than the submission of their bids.

6. The SSS will hold a Pre-Bid Conference on the date and time specified above at the Bidding Room, 2nd Floor, SSS Main Bldg., East Avenue, Diliman, Quezon City which shall be open to prospective bidders, but attendance shall not be mandatory.

The Pre-Bid Conference will be conducted through online conference using Microsoft Teams. Kindly e-mail us on or before 12 July 2022, through e-mail address bac@sss.gov.ph, the following:

- a. Name of the representative and e-mail address; and
- b. Technical and administrative queries.

7. Bids must be duly received by the BAC Secretariat at the Bidding Room, 2nd Floor, SSS Main Building, East Avenue, Diliman, Quezon City on the deadline specified above. All Bids must be accompanied by a bid security in any of the acceptable forms and in the amount stated in the ITB Clause 14.

Bid opening shall be on the date and time specified above at the Bidding Room, 2nd Floor, SSS Main Building, East Avenue, Diliman, Quezon City. Bids will be opened in the presence of the Bidders' representatives who choose to attend at the address above. Late bids shall not be accepted.

8. References to the dates and times shall be based on Philippine Standard time. Should any of the above dates fall on a holiday, the deadline shall be extended to the same time on the immediately succeeding business day in Quezon City.
9. The SSS reserves the right to reject any and all bids, declare a failure of bidding, or not award the contract at any time prior to contract award in accordance with Sections 35.6 and 41 of the 2016 revised IRR of RA No. 9184, without thereby incurring any liability to the affected bidder or bidders.
10. The SSS assumes no obligation to compensate or indemnify parties for any expense or loss that they may incur as a result of their participation in the procurement process, nor does SSS BAC guarantees that an award will be made as a result of this invitation. Furthermore, the SSS reserves the right to waive any defects or formality in the responses to the eligibility requirements and to this invitation and reserves the right to accept the proposal most advantageous to the agency.
11. For further information, please refer to:

Bids & Awards Committee

The Secretariat

2nd Flr., SSS Main Bldg., East Ave., Diliman, Q.C.
Tel # (632) 8922-1070; 8709-7198 local 5492 & 6382
Email – bac@sss.gov.ph

12. Bidding documents may be downloaded from the PROCUREMENT tab at www.sss.gov.ph starting **04 July 2022**.

**THE VICE CHAIRPERSON
BIDS & AWARDS COMMITTEE**
*
Chair on
leave

ref.: itb-sss-civil-2022-002-Renovation of SSS Baguio

Section II. Instructions to Bidders

1. Scope of Bid

The Procuring Entity, *Social Security System* wishes to receive Bids for the Renovation of 4th Floor (COA, RIMT Records Room, Network Room and Storage Room) and Various Improvements at Ground Floor (Info Kiosk, Electrical Room and Vault Room) at SSS Baguio Building, with identification number ITB-SSS-Civil-2022-002.

The Procurement Project (referred to herein as “Project”) is for the construction of Works, as described in Section VI (Specifications).

2. Funding Information

2.1. The GOP through the source of funding as indicated below for *CY 2022* in the amount of **Four Million Seven Hundred Forty Thousand Six Pesos and 00/100 (₱4,740,006.00)**, broken down as follows:

1. Renovation of 4th Floor at SSS Baguio (COA, RIMT, Records Room Area, Network Room and Storage Room) - ₱4,399,391.00
2. Various Improvements at SSS Baguio (info kiosk, electrical room and vault at ground floor) - ₱ 340,615.00

2.2. The source of funding is: 2022 Corporate Operating Budget under MOOE of the 2022 Annual Procurement Plan:

1. Renovation of 4th Floor at SSS Baguio (COA, RIMT, Records Room Area, Network Room and Storage Room) - ₱4,399,391.00 (Code PAP 2022-134)
2. Various Improvements at SSS Baguio (Info Kiosk, Electrical Room and Vault Room at Ground Floor) - ₱ 340,615.00 (Code PAP 2022-135)

3. Bidding Requirements

The Bidding for the Project shall be governed by all the provisions of RA No. 9184 and its 2016 revised IRR, including its Generic Procurement Manual and associated policies, rules and regulations as the primary source thereof, while the herein clauses shall serve as the secondary source thereof.

Any amendments made to the IRR and other GPPB issuances shall be applicable only to the ongoing posting, advertisement, or invitation to bid by the BAC through the issuance of a supplemental or bid bulletin.

The Bidder, by the act of submitting its Bid, shall be deemed to have inspected the site, determined the general characteristics of the contracted Works and the conditions for this Project, such as the location and the nature of the work; (b) climatic conditions; (c) transportation facilities; (c) nature and condition of the terrain, geological conditions at the site communication facilities, requirements, location and availability of construction aggregates and other materials, labor, water, electric power and access roads; and (d) other factors that may affect the cost, duration and execution or implementation of the contract, project, or work and examine all instructions, forms, terms, and project requirements in the Bidding Documents.

4. Corrupt, Fraudulent, Collusive, Coercive, and Obstructive Practices

The Procuring Entity, as well as the Bidders and Contractors, shall observe the highest standard of ethics during the procurement and execution of the contract. They or through an agent shall not engage in corrupt, fraudulent, collusive, coercive, and obstructive practices defined under Annex “P” of the 2016 revised IRR of RA No. 9184 or other integrity violations in competing for the Project.

5. Eligible Bidders

5.1. Only Bids of Bidders found to be legally, technically, and financially capable will be evaluated.

5.2. The Bidder must have an experience of having completed a Single Largest Completed Contract (SLCC) that is similar to this Project, equivalent to at least fifty percent (50%) of the ABC adjusted, if necessary, by the Bidder to current prices using the PSA’s CPI, except under conditions provided for in Section 23.4.2.4 of the 2016 revised IRR of RA No. 9184.

A contract is considered to be “similar” to the contract to be bid if it has the major categories of work stated in the **BDS**.

5.3. For Foreign-funded Procurement, the Procuring Entity and the foreign government/foreign or international financing institution may agree on another track record requirement, as specified in the Bidding Document prepared for this purpose.

5.4. The Bidders shall comply with the eligibility criteria under Section 23.4.2 of the 2016 IRR of RA No. 9184.

6. Origin of Associated Goods

There is no restriction on the origin of Goods other than those prohibited by a decision of the UN Security Council taken under Chapter VII of the Charter of the UN.

7. Subcontracts

7.1. The Procuring Entity has prescribed that: **Subcontracting is not allowed.**

8. Pre-Bid Conference

The Procuring Entity will hold a pre-bid conference for this Project on the specified date and time and either at its physical address **Bidding Room, 2nd Floor, SSS Main Building, East Avenue, Diliman, Quezon City and/or through online conference using Microsoft Teams** as indicated in paragraph 6 of the **IB**.

9. Clarification and Amendment of Bidding Documents

Prospective bidders may request for clarification on and/or interpretation of any part of the Bidding Documents. Such requests must be in writing and received by the Procuring Entity, either at its given address or through electronic mail indicated in the **IB**, at least ten (10) calendar days before the deadline set for the submission and receipt of Bids.

10. Documents Comprising the Bid: Eligibility and Technical Components

10.1. The first envelope shall contain the eligibility and technical documents of the Bid as specified in **Section IX. Checklist of Technical and Financial Documents**.

10.2. If the eligibility requirements or statements, the bids, and all other documents for submission to the BAC are in foreign language other than English, it must be accompanied by a translation in English, which shall be authenticated by the appropriate Philippine foreign service establishment, post, or the equivalent office having jurisdiction over the foreign bidder’s affairs in the Philippines.

For Contracting Parties to the Apostille Convention, only the translated documents shall be authenticated through an apostille pursuant to GPPB Resolution No. 13-2019 dated 23 May 2019. The English translation shall govern, for purposes of interpretation of the bid.

- 10.3. A valid PCAB License is required, and in case of joint ventures, a valid special PCAB License, and registration for the type and cost of the contract for this Project. Any additional type of Contractor license or permit shall be indicated in the **BDS**.
- 10.4. A List of Contractor's key personnel (e.g., Project Manager, Project Engineers, Materials Engineers, and Foremen) assigned to the contract to be bid, with their complete qualification and experience data shall be provided. These key personnel must meet the required minimum years of experience set in the **BDS**.
- 10.5. A List of Contractor's major equipment units, which are owned, leased, and/or under purchase agreements, supported by proof of ownership, certification of availability of equipment from the equipment lessor/vendor for the duration of the project, as the case may be, must meet the minimum requirements for the contract set in the **BDS**.

11. Documents Comprising the Bid: Financial Component

- 11.1. The second bid envelope shall contain the financial documents for the Bid as specified in **Section IX. Checklist of Technical and Financial Documents**.
- 11.2. Any bid exceeding the ABC indicated in paragraph 1 of the **IB** shall not be accepted.
- 11.3. For Foreign-funded procurement, a ceiling may be applied to bid prices provided the conditions are met under Section 31.2 of the 2016 revised IRR of RA No. 9184.

12. Alternative Bids

Bidders shall submit offers that comply with the requirements of the Bidding Documents, including the basic technical design as indicated in the drawings and specifications. Unless there is a value engineering clause in the **BDS**, alternative Bids shall not be accepted.

13. Bid Prices

All bid prices for the given scope of work in the Project as awarded shall be considered as fixed prices, and therefore not subject to price escalation during contract implementation, except under extraordinary circumstances as determined by the NEDA and approved by the GPPB pursuant to the revised Guidelines for Contract Price Escalation guidelines.

14. Bid and Payment Currencies

- 14.1. Bid prices may be quoted in the local currency or tradeable currency accepted by the BSP at the discretion of the Bidder. However, for purposes of bid evaluation, Bids denominated in foreign currencies shall be converted to Philippine currency based on the exchange rate as published in the BSP reference rate bulletin on the day of the bid opening.
- 14.2. Payment of the contract price shall be made in Philippine Pesos.

15. Bid Security

- 15.1. The Bidder shall submit a Bid Securing Declaration or any form of Bid Security in the amount indicated in the **BDS**, which shall be not less than the percentage of the ABC in accordance with the schedule in the **BDS**.
- 15.2. The Bid and bid security shall be valid until one hundred twenty (120) calendar days from the date of the bid opening. Any bid not accompanied by an acceptable bid security shall be rejected by the Procuring Entity as non-responsive.

16. Sealing and Marking of Bids

Each Bidder shall submit one copy of the first and second components of its Bid.

The Procuring Entity may request additional hard copies and/or electronic copies of the Bid. However, failure of the Bidders to comply with the said request shall not be a ground for disqualification.

If the Procuring Entity allows the submission of bids through online submission to the given website or any other electronic means, the Bidder shall submit an electronic copy of its Bid, which must be digitally signed. An electronic copy that cannot be opened or is corrupted shall be considered non-responsive and, thus, automatically disqualified.

17. Deadline for Submission of Bids

The Bidders shall submit on the specified date and time and either at its physical address or through online submission as indicated in paragraph 7 of the **IB**.

18. Opening and Preliminary Examination of Bids

18.1. The BAC shall open the Bids in public at the time, on the date, and at the place specified in paragraph 9 of the **IB**. The Bidders' representatives who are present shall sign a register evidencing their attendance. In case videoconferencing, webcasting or other similar technologies will be used, attendance of participants shall likewise be recorded by the BAC Secretariat.

In case the Bids cannot be opened as scheduled due to justifiable reasons, the rescheduling requirements under Section 29 of the 2016 revised IRR of RA No. 9184 shall prevail.

18.2. The preliminary examination of Bids shall be governed by Section 30 of the 2016 revised IRR of RA No. 9184.

19. Detailed Evaluation and Comparison of Bids

19.1. The Procuring Entity's BAC shall immediately conduct a detailed evaluation of all Bids rated "*passed*" using non-discretionary pass/fail criteria. The BAC shall consider the conditions in the evaluation of Bids under Section 32.2 of 2016 revised IRR of RA No. 9184.

19.2. If the Project allows partial bids, all Bids and combinations of Bids as indicated in the **BDS** shall be received by the same deadline and opened and evaluated simultaneously so as to determine the Bid or combination of Bids offering the lowest calculated cost to the Procuring Entity. Bid Security as required by **ITB** Clause 15 shall be submitted for each contract (lot) separately.

19.3. In all cases, the NFCC computation pursuant to Section 23.4.2.6 of the 2016 revised IRR of RA No. 9184 must be sufficient for the total of the ABCs for all the lots participated in by the prospective Bidder.

20. Post Qualification

Within a non-extendible period of five (5) calendar days from receipt by the Bidder of the notice from the BAC that it submitted the Lowest Calculated Bid, the Bidder shall submit its latest income and business tax returns filed and paid through the BIR Electronic Filing and Payment System (eFPS), and other appropriate licenses and permits required by law and stated in the **BDS**.

21. Signing of the Contract

The documents required in Section 37.2 of the 2016 revised IRR of RA No. 9184 shall form part of the Contract. Additional Contract documents are indicated in the **BDS**.

Section III. Bid Data Sheet

Bid Data Sheet

ITB Clause													
5.2	<p>For this purpose, contracts similar to the Project refer to contracts which have the same major categories of work, which shall be:</p> <p>a) Comprised of civil-architectural, electrical and specialty works as detailed in the Specifications and Bill of Quantities (BOQ) Form, and</p> <p>b) Completed within (5) five years prior to the submission and opening of bid</p>												
7.1	Subcontracting is not allowed.												
10.3	<p>PCAB License and Registration:</p> <p>License Category : C & D Size Range : Small B Classification : General Building</p> <p>The bidder shall have at least five (5) years of experience in construction/renovation including specialty works, as indicated in the BOQ and Specifications.</p> <p>In case of joint ventures, a valid special PCAB License, and registration for the type and cost of the contract for this Project.</p>												
10.4	<p>The key personnel must meet the required minimum years of experience set below:</p> <table border="1" style="width: 100%; border-collapse: collapse; margin: 10px 0;"> <thead> <tr> <th style="text-align: center;">Key Personnel</th> <th style="text-align: center;">Required no. of years of relevant work experience</th> <th style="text-align: center;">Field of Experience</th> </tr> </thead> <tbody> <tr> <td>Project Manager</td> <td style="text-align: center;">5 years</td> <td>Construction / Renovation Works</td> </tr> <tr> <td>Project Engineer/Architect</td> <td style="text-align: center;">3 years</td> <td>Construction / Renovation Works</td> </tr> <tr> <td>Foreman</td> <td style="text-align: center;">3 years</td> <td>Construction / Renovation Works</td> </tr> </tbody> </table> <p>Except for the Foreman, all key personnel should be PRC-registered engineers / architects in good standing.</p>	Key Personnel	Required no. of years of relevant work experience	Field of Experience	Project Manager	5 years	Construction / Renovation Works	Project Engineer/Architect	3 years	Construction / Renovation Works	Foreman	3 years	Construction / Renovation Works
Key Personnel	Required no. of years of relevant work experience	Field of Experience											
Project Manager	5 years	Construction / Renovation Works											
Project Engineer/Architect	3 years	Construction / Renovation Works											
Foreman	3 years	Construction / Renovation Works											
10.5	<p>The minimum major equipment requirements are the following:</p> <p>a. 1 unit-delivery truck 2000kg</p> <p>b. 2 unit-electric drill 600watts</p> <p>c. 2 unit-electric grinder 13amp</p>												
12	No further instruction.												
15.1	<p>The bid security shall be in the form of a Bid Securing Declaration or any of the following forms and amounts:</p> <p>a. The amount of not less than Php94,800.12 (2% of ABC), if bid security is in cash, cashier's/manager's check, bank draft/guarantee or irrevocable letter of credit;</p> <p>b. The amount of not less than Php237,000.30 (5% of ABC), if bid security is in Surety Bond.</p>												
19.2	Partial bid is not allowed. The infrastructure project is packaged in a single lot and the lot shall not be divided into sub-lots for the purpose of bidding, evaluation, and contract award.												



20	<p>The Lowest Calculated Bidder shall submit the following:</p> <ol style="list-style-type: none"> 1. Registration certificate from Securities and Exchange Commission (SEC), for corporation including Articles of Incorporation and General Information Sheet (GIS), Department of Trade and Industry (DTI) for sole proprietorship, or Cooperative Development Authority (CDA) for cooperatives or its equivalent document. 2. Mayor's or Business permit issued by the city or municipality where the principal place of business of the prospective bidder is located, or the equivalent document for Exclusive Economic Zones or Areas; 3. Tax clearance per E.O. No. 398, s. 2005, as finally reviewed and approved by the Bureau of Internal Revenue (BIR) 4. Latest Audited Financial Statements 5. Latest income tax return corresponding to the Audited Financial Statements submitted, filed electronically (EFPS); 6. Quarterly VAT (business tax returns) per Revenue Regulations 3-2005 for the last six (6) months prior to the submission and opening of bids filed electronically (EFPS);
21	Not applicable

Section IV. General Conditions of Contract

1. Scope of Contract

This Contract shall include all such items, although not specifically mentioned, that can be reasonably inferred as being required for its completion as if such items were expressly mentioned herein. All the provisions of RA No. 9184 and its 2016 revised IRR, including the Generic Procurement Manual, and associated issuances, constitute the primary source for the terms and conditions of the Contract, and thus, applicable in contract implementation. Herein clauses shall serve as the secondary source for the terms and conditions of the Contract.

This is without prejudice to Sections 74.1 and 74.2 of the 2016 revised IRR of RA No. 9184 allowing the GPPB to amend the IRR, which shall be applied to all procurement activities, the advertisement, posting, or invitation of which were issued after the effectivity of the said amendment.

2. Sectional Completion of Works

If sectional completion is specified in the **Special Conditions of Contract (SCC)**, references in the Conditions of Contract to the Works, the Completion Date, and the Intended Completion Date shall apply to any Section of the Works (other than references to the Completion Date and Intended Completion Date for the whole of the Works).

3. Possession of Site

- 3.1 The Procuring Entity shall give possession of all or parts of the Site to the Contractor based on the schedule of delivery indicated in the **SCC**, which corresponds to the execution of the Works. If the Contractor suffers delay or incurs cost from failure on the part of the Procuring Entity to give possession in accordance with the terms of this clause, the Procuring Entity's Representative shall give the Contractor a Contract Time Extension and certify such sum as fair to cover the cost incurred, which sum shall be paid by Procuring Entity.
- 3.2 If possession of a portion is not given by the above date, the Procuring Entity will be deemed to have delayed the start of the relevant activities. The resulting adjustments in contract time to address such delay may be addressed through contract extension provided under Annex "E" of the 2016 revised IRR of RA No. 9184.

4. The Contractor's Obligations

The Contractor shall employ the key personnel named in the Schedule of Key Personnel indicating their designation, in accordance with **ITB** Clause 10.3 and specified in the **BDS**, to carry out the supervision of the Works.

The Procuring Entity will approve any proposed replacement of key personnel only if their relevant qualifications and abilities are equal to or better than those of the personnel listed in the Schedule.

5. Performance Security

- 5.1. Within ten (10) calendar days from receipt of the Notice of Award from the Procuring Entity but in no case later than the signing of the contract by both parties, the successful Bidder shall furnish the performance security in any of the forms prescribed in Section 39 of the 2016 revised IRR.

5.2. The Contractor, by entering into the Contract with the Procuring Entity, acknowledges the right of the Procuring Entity to institute action pursuant to RA No. 3688 against any subcontractor be they an individual, firm, partnership, corporation, or association supplying the Contractor with labor, materials and/or equipment for the performance of this Contract.

6. Site Investigation Reports

The Contractor, in preparing the Bid, shall rely on any Site Investigation Reports referred to in the **SCC** supplemented by any information obtained by the Contractor.

7. Warranty

7.1. In case the Contractor fails to undertake the repair works under Section 62.2.2 of the 2016 revised IRR, the Procuring Entity shall forfeit its performance security, subject its property(ies) to attachment or garnishment proceedings, and perpetually disqualify it from participating in any public bidding. All payables of the GOP in his favor shall be offset to recover the costs.

7.2. The warranty against Structural Defects/Failures, except that occasioned-on force majeure, shall cover the period from the date of issuance of the Certificate of Final Acceptance by the Procuring Entity. Specific duration of the warranty is found in the **SCC**.

8. Liability of the Contractor

Subject to additional provisions, if any, set forth in the **SCC**, the Contractor's liability under this Contract shall be as provided by the laws of the Republic of the Philippines.

If the Contractor is a joint venture, all partners to the joint venture shall be jointly and severally liable to the Procuring Entity.

9. Termination for Other Causes

Contract termination shall be initiated in case it is determined *prima facie* by the Procuring Entity that the Contractor has engaged, before, or during the implementation of the contract, in unlawful deeds and behaviors relative to contract acquisition and implementation, such as, but not limited to corrupt, fraudulent, collusive, coercive, and obstructive practices as stated in **ITB** Clause 4.

10. Dayworks

Subject to the guidelines on Variation Order in Annex "E" of the 2016 revised IRR of RA No. 9184, and if applicable as indicated in the **SCC**, the Dayworks rates in the Contractor's Bid shall be used for small additional amounts of work only when the Procuring Entity's Representative has given written instructions in advance for additional work to be paid for in that way.

11. Program of Work

11.1. The Contractor shall submit to the Procuring Entity's Representative for approval the said Program of Work showing the general methods, arrangements, order, and timing for all the activities in the Works. The submissions of the Program of Work are indicated in the **SCC**.

- 11.2. The Contractor shall submit to the Procuring Entity's Representative for approval an updated Program of Work at intervals no longer than the period stated in the **SCC**. If the Contractor does not submit an updated Program of Work within this period, the Procuring Entity's Representative may withhold the amount stated in the **SCC** from the next payment certificate and continue to withhold this amount until the next payment after the date on which the overdue Program of Work has been submitted.

12. Instructions, Inspections and Audits

The Contractor shall permit the GOP or the Procuring Entity to inspect the Contractor's accounts and records relating to the performance of the Contractor and to have them audited by auditors of the GOP or the Procuring Entity, as may be required.

13. Advance Payment

The Procuring Entity shall, upon a written request of the Contractor which shall be submitted as a Contract document, make an advance payment to the Contractor in an amount not exceeding fifteen percent (15%) of the total contract price, to be made in lump sum, or at the most two installments according to a schedule specified in the **SCC**, subject to the requirements in Annex "E" of the 2016 revised IRR of RA No. 9184.

14. Progress Payments

The Contractor may submit a request for payment for Work accomplished. Such requests for payment shall be verified and certified by the Procuring Entity's Representative/Project Engineer. Except as otherwise stipulated in the **SCC**, materials and equipment delivered on the site but not completely put in place shall not be included for payment.

15. Operating and Maintenance Manuals

- 15.1. If required, the Contractor will provide "as built" Drawings and/or operating and maintenance manuals as specified in the **SCC**.
- 15.2. If the Contractor does not provide the Drawings and/or manuals by the dates stated above, or they do not receive the Procuring Entity's Representative's approval, the Procuring Entity's Representative may withhold the amount stated in the **SCC** from payments due to the Contractor.

Section V. Special Conditions of Contract

Special Conditions of Contract

GCC Clause	
2	No sectional completion date
3.1	The Procuring Entity shall give possession of all parts of the Site to the Contractor for the duration of the Contract (150 calendar days) which shall commence upon receipt of the Notice to Proceed and Contract/Job Order.
6	Not applicable
7.2	Not applicable
8	<p>Liability of the Contractor</p> <p>1. CONFIDENTIALITY. Neither party shall, without the prior written consent of the other, disclose or make available to any person, make public, or use directly or indirectly, except for the performance and implementation of the works, any confidential information, acquired from an information holder in connection with the performance of this Contract, unless: (i) the information is known to the disclosing party, as evidenced by its written records, prior to obtaining the same from the information holder and is not otherwise subject to disclosure restrictions on the disclosing party, (ii) the information is disclosed to the disclosing party by a third party who did not receive the same, directly or indirectly, from an information holder, and who has no obligation of secrecy with respect thereto, or (iii) required to be disclosed by law.</p> <p>The obligation of confidentiality by both parties, as provided herein, shall survive the termination of the Agreement.</p> <p>2. MERGER AND CONSOLIDATION. In case of merger, consolidation or change of ownership of the CONTRACTOR with other company, it is the responsibility of the surviving company/consolidated company/acquiring entity to inform SSS of the change in corporate structure/ownership. Failure to do so shall translate in such company assuming all liabilities of the acquired/merged company under the Agreement.</p> <p>3. FORCE MAJEURE. SUPPLIER shall not be liable for forfeiture of its performance security, liquidated damages, or termination for default if and to the extent that CONTRACTOR's delay in performance or other failure to perform its obligations under this Agreement is the result of a force majeure.</p> <p>For purposes of this Agreement the terms "force majeure" and "fortuitous event" may be used interchangeably. In this regard, a fortuitous event or force majeure shall be interpreted to mean an event which CONTRACTOR could not have foreseen, or which though foreseen, was inevitable. It shall not include ordinary unfavorable weather conditions; and any other cause the effects of which could have been avoided with the exercise of reasonable diligence by CONTRACTOR. Such events may include, but not limited to, acts of SSS in its sovereign capacity, wars or revolutions, fires, floods, epidemics, quarantine restrictions, and freight embargoes.</p> <p>If a force majeure situation arises, CONTRACTOR shall promptly notify SSS in writing of such condition and the cause thereof. Unless otherwise directed by SSS in writing, CONTRACTOR shall continue to perform its obligations under this Agreement as far as is reasonably practical and shall seek all reasonable alternative means for performance not prevented by the force majeure.</p>



4. **NON-ASSIGNMENT.** CONTRACTOR shall not assign its rights or obligations under this Agreement, in whole or in part, except with SSS's prior written consent. CONTRACTOR shall not subcontract in whole or in part the PROJECT and deliverables subject of this Agreement without the written consent of SSS.
5. **WAIVER.** Failure by either party to insist upon the other strict performance of any of the terms and conditions hereof shall not be deemed a relinquishment or waiver of any subsequent breach or default of the terms and conditions hereof, which can only be deemed made if expressed in writing and signed by its duly authorized representative. No such waiver shall be construed as modification of any of the provisions of the Agreement or as a waiver of any past or future default or breach hereof, except as expressly stated in such waiver.
6. **CUMULATIVE REMEDIES.** Any and all remedies granted to the parties under the applicable laws and the Contract shall be deemed cumulative and may therefore, at the sole option and discretion, be availed of by the aggrieved party simultaneously, successively, or independently.
7. **NO EMPLOYER-EMPLOYEE RELATIONSHIP.** It is expressly and manifestly understood and agreed upon that the employees of CONTRACTOR assigned to perform the PROJECT are not employees of SSS. Neither is there an employer-employee relationship between SSS and CONTRACTOR.

The Agreement does not create an employer-employee relationship between SSS and the CONTRACTOR including its personnel; that the services rendered by the personnel assigned by CONTRACTOR to SSS in the performance of its obligation under the contract do not represent government service and will not be credited as such; that its personnel assigned to SSS are not entitled to benefits enjoyed by SSS' officials and employees such as Personal Economic Relief Allowance (PERA), Representation and Transportation Allowance (RATA), ACA, etc.; that these personnel are not related within the third degree of consanguinity or affinity to the contracting officer and appointing authority of SSS; that they have not been previously dismissed from the government service by reason of an administrative case; that they have not reached the compulsory retirement age of sixty-five (65); and that they possess the education, experience and skills required to perform the job. The CONTRACTOR hereby acknowledges that no authority has been given by SSS to hire any person as an employee of the latter. Any instruction given by SSS or any of its personnel to CONTRACTOR's employees are to be construed merely as a measure taken by the former to ensure and enhance the quality of project performed hereunder. The CONTRACTOR shall, at all times, exercise supervision and control over its employees in the performance of its obligations under the contract.
8. **PARTNERSHIP.** Nothing in the contract shall constitute a partnership between the parties. No party or its agents or employees shall be deemed to be the agent, employee or representative of any other party.
9. **COMPLIANCE WITH SS LAW.** CONTRACTOR shall report all its employees to SSS for coverage and their contributions, as well as, all amortizations for salary/education/calamity and other SSS loans shall be updated. Should CONTRACTOR fail to comply with its obligations under the provisions of the SS Law and Employees' Compensation Act, SSS shall have the authority to deduct any unpaid SS and EC contributions, salary, educational, emergency and/or calamity loan amortizations, employer's liability for damages, including interests and penalties from CONTRACTOR's receivables under this Agreement.

Further, prescription does not run against SSS for its failure to demand SS contributions or payments from CONTRACTOR. Moreover, CONTRACTOR shall forever hold in trust SS contributions or payments of its employees until the same is fully remitted to SSS.

10. COMPLIANCE WITH LABOR LAWS. CONTRACTOR, as employer of the personnel assigned to undertake the PROJECT, shall comply with all its obligations under existing laws and their implementing rules and regulations on the payment of minimum wage, overtime pay, and other labor-related benefits as well as remittances or payment of the appropriate amount or contributions/payment (SSS, EC, Pag-IBIG, PhilHealth and taxes) with concerned government agencies/offices.

It is agreed further, that prior to the release of any payment by SSS to SUPPLIER, its President or its duly authorized representative, shall submit a sworn statement that all monies due to all its employees assigned to the PROJECT as well as benefits by law and other related labor legislation have been paid by CONTRACTOR and that he/she assumed full responsibility thereof.

11. COMPLIANCE WITH TAX LAWS. CONTRACTOR shall, in compliance with tax laws, pay the applicable taxes in full and on time and shall regularly present to SSS within the duration of the Contract, tax clearance from the Bureau of Internal Revenue (BIR) as well as copy of its income and business tax returns duly stamped by the BIR and duly validated with the tax payments made thereon. Failure by CONTRACTOR to comply with the foregoing shall entitle SSS to suspend payment of the Contract Price.

As required under Executive Order (EO) 398, s. 2005, CONTRACTOR shall submit income and business tax returns duly stamped and received by the BIR, before entering and during the duration of this Agreement. CONTRACTOR, through its responsible officer, shall also certify under oath that it is free and clear of all tax liabilities to the government. CONTRACTOR shall pay taxes in full and on time and that failure to do so will entitle SSS to suspend or terminate this Agreement.

12. LIQUIDATED DAMAGES. If CONTRACTOR fails to satisfactorily deliver any or all of the Goods and/or to perform the Services within the period(s) specified in the PBD inclusive of duly granted time extensions if any, SSS shall, without prejudice to its other remedies under this Agreement and under the applicable law, deduct from the Contract Price, as liquidated damages, the applicable rate of one tenth (1/10) of one (1) percent of the cost of the unperformed portion for every day of delay until actual delivery or performance. Once the amount of liquidated damages reaches ten percent (10%), SSS may rescind or terminate this Agreement, without prejudice to other courses of action and remedies open to it.

13. HOLD FREE and HARMLESS. SUPPLIER agrees to defend, indemnify, and hold SSS free and harmless from any and all claims, damages, expenses, fines, penalties and/or liabilities of whatever nature and kind, whether in law or equity, that may arise by reason of the implementation of the Agreement. In addition, CONTRACTOR agrees to indemnify SSS for any damage as a result of said implementation.

SUPPLIER hereby assumes full responsibility for any injury, including death, loss or damage which may be caused to SSS' employees or property or third person due to CONTRACTOR's employees' fault or negligence, and further binds itself to hold SSS free and harmless from any of such injury or damage. SSS shall not be responsible for any injury, loss or damage which CONTRACTOR or any of its employees may sustain in the performance of CONTRACTOR's obligations under this Agreement.

14. SETTLEMENT OF DISPUTES. If any dispute or difference of any kind whatsoever shall arise between SSS and CONTRACTOR in connection with or arising out of this Agreement, the Parties shall make every effort to resolve amicably such dispute or difference by mutual consultation.

	<p>If after thirty (30) days, the Parties have failed to resolve their dispute or difference by such mutual consultation, then either SSS or CONTRACTOR may give notice to the other Party of its intention to commence arbitration, in accordance with RA No. 876, otherwise known as the “Arbitration Law” and RA No. 9285, otherwise known as the “Alternative Dispute Resolution Act of 2004,” in order to settle their disputes.</p> <p>No arbitration in respect of this matter may be commenced unless such notice is given.</p> <p>Notwithstanding any reference to arbitration herein, the Parties shall continue to perform their respective obligations under this Agreement unless they otherwise agree.</p> <p>15. VENUE OF ACTIONS. In the event court action is necessary in order to promote Arbitration, such action shall be filed only before the proper courts of Quezon City, to the exclusion of all other venues.</p> <p>16. GOVERNING LAW. The Agreement shall be governed by and interpreted according to the laws of the Republic of the Philippines.</p> <p>17. AMENDMENTS. This Agreement may be amended only in writing and executed by the parties or their duly authorized representatives.</p> <p>18. SEPARABILITY. If any one or more of the provisions contained in the contract or any document executed in connection herewith shall be invalid, illegal or unenforceable in any respect under any applicable law, then: (i) the validity, legality and enforceability of the remaining provisions contained herein or therein shall not in any way be affected or impaired and shall remain in full force and effect; and (ii) the invalid, illegal or unenforceable provision shall be replaced by the parties immediately with a term or provision that is valid, legal and enforceable and that comes closest to expressing the intention of such invalid illegal or unenforceable term of provision.</p> <p>19. BINDING EFFECT. The Agreement shall be binding upon the Parties hereto, their assignee/s and successor/s-in-interest.</p>						
10	Dayworks are applicable at the rate shown in the Contractor’s original Bid.						
11.1	The Contractor shall submit the Program of Work, Construction schedule and S-curve, manpower schedule, construction methods, equipment utilization schedule, construction safety and health program approved by the Department of Labor and Employment to the Procuring Entity’s Representative within five (5) calendar days after the conduct of pre-construction meeting.						
11.2	<p>The period between Program of Work updates is seven (7) calendar days.</p> <p>The amount to be withheld for late submission of an updated Program of Work is ten percent (10%) of the cost of accomplishment of the progress billing, on top of applicable ten percent (10%) retention money.</p>						
13	The amount of the advance payment is 15% of the total contract price to be deducted in a pro-rated basis every Progress Billing.						
14	<p>Progress payment may be made in three (3) billings and upon written request by the Contractor, following the matrix below:</p> <table border="1" data-bbox="407 2198 1344 2413"> <thead> <tr> <th data-bbox="407 2198 724 2279">PROGRESS PAYMENT</th> <th data-bbox="724 2198 1344 2279">BASIS OF PAYMENT</th> </tr> </thead> <tbody> <tr> <td data-bbox="407 2279 724 2346">1st Billing</td> <td data-bbox="724 2279 1344 2346">20% or more work accomplishment.</td> </tr> <tr> <td data-bbox="407 2346 724 2413">2nd Billing</td> <td data-bbox="724 2346 1344 2413">75% or more work accomplishment</td> </tr> </tbody> </table>	PROGRESS PAYMENT	BASIS OF PAYMENT	1 st Billing	20% or more work accomplishment.	2 nd Billing	75% or more work accomplishment
PROGRESS PAYMENT	BASIS OF PAYMENT						
1 st Billing	20% or more work accomplishment.						
2 nd Billing	75% or more work accomplishment						



	3 rd or Final Billing	One hundred percent (100%) completion of the project and upon issuance of Certificate of Completion as certified by the Procuring Entity's Representative	
	Materials and equipment delivered on the site but not completely put in place shall not be included for payment.		
15.1	The date by which "as built" drawings are required is within two (2) weeks after the completion of the project.		
15.2	The amount to be withheld for failing to produce "as built" drawings by the date required is ten percent (10%) of the Contract Price.		

Section VI. Specifications

I. PROGRAM OF WORKS

A. GENERAL REQUIREMENTS

- a. Renovation Permits / Clearances, As-built plans
- b. Signed and sealed As-built Plans

B. WORKMANSHIP

All required phases of work shall be done by skilled and competent men who are regularly engaged or specialized in the type of work specified. Workmanship shall be the very best trade practice.

C. SITE EXAMINATION

Examine the site premises and all conditions apparent and visible therein. Consider all such conditions that may affect work. Measure every existing work/structure at site. Verify all given dimensions and deviations in the plans / drawings and Bill of Quantities. It shall be understood that the work covers all exposed external surfaces regardless of measurements made.

D. PROTECTION OF WORK AND PROPERTY

Provide adequate protection on the existing furniture, equipment, and other areas not affected by the work specified. Place warning signs where work is being undertaken. Remove work materials damaged by failure to provide protection. Replace with new work materials at no extra cost to the Owner.

E. SUBMITTALS

The Contractor shall submit samples of finishes, furnished materials and equivalent materials for approval by the Engineering & Maintenance Department prior to installation / application.

F. QUALITY OF MATERIALS

All replacement materials shall be new, free from defects, passed and conformed to International Standard and Philippine Standard set forth by Bureau of Product Standards - Department of Trade and Industry.

G. CLEANING

Leave premises clean, neat and orderly. Remove all stains, spots, blemishes, soil dirt from all finished work. Remove all excess materials, soil, used containers, tools, equipment and supplies out of the SSS premises during the progress of work and upon completion of work.

H. AS-BUILT PLAN AND ELECTRONIC FILE

Three (3) sets 20" x 30" blue print as-built plans duly signed and sealed by the Contractor's Civil Engineer or Architect for Civil and Architectural plans, Electrical Engineer for Electrical and Structured Cabling Plans.

The contractor shall likewise submit electronic file copy as-built plan using AutoCAD software on USB or CD.

I. OPERATION & MAINTENANCE MANUALS

The Contractor shall submit and provide Operation and Maintenance Manuals for all installed electrical and mechanical equipment to SSS Authorized Representative.

II. SCOPE OF WORKS AND MATERIAL SPECIFICATIONS

The work contemplated under this contract shall consist of furnishing of all materials, labor, plant, tools and equipment, permits including the satisfactory performance of all work necessary for the complete execution of all the work as shown on the plans, specifications and other contract documents.

1. RENOVATION OF 4TH FLOOR AT SSS BAGUIO (COA, RIMT, RECORDS ROOM AREA, NETWORK ROOM AND STORAGE ROOM)

A. SCOPE OF WORK

1. Site Preparation

- a. Mobilization / Demobilization
- b. Temporary Facilities, Protective Covering and Board-up/Site Enclosure, Safety Signage
- c. Demolition/Dismantling Works which include Wall Partitions, Doors, Windows, Ceiling, Cabinets and other structures affected by the renovation works
- d. Hauling & Disposal of Debris & Waste Materials

2. Carpentry Works

- a. Supply & Installation of new 16mm thick acoustic ceiling board on CMT Powder Coated Aluminum Frame (COA Office, Office Space for Expansion, Elevator Lobby) and new 6mm thick fiber cement board ceiling on CMT Powder Coated Aluminum Frame (RIMT Records Room, COA Records Room, Storage for Building and Network Office & Storage Room) and new 6mm thick fiber cement board light metal frames (Cove Ceiling at the windows)
- b. Construction of Drywall Partition on Metal Studs Frame (COA Office, COA Records Room, Building Admin & Network Office, Data/Network Room, RIMT Records Rooms, Hallway)
- c. Supply & Installation of Wooden Doors WD-01 & WD-02
- d. Repair of Floor Cover for the raceway as specified on the plan

3. Architectural/Specialty Works

- a. Supply & Installation of Glass Partitions, Doors & Windows, Door w/ transom:
 - Glass Partition: GP-01, 1.20 m x 2.54 m, 12mm thk Tempered Glass Panels and Single Leaf Door w/ FD100 Top & Bottom Frame, Stainless Steel Door Handles, Complete w/ Patch Fittings, Hardwares & Accessories (COA Office)
 - Glass Door: GD-01, 1.00 m x 2.54 m, 12mm thk Tempered Glass Single Leaf Door on FD100 Top & Bottom w/ Transom on Aluminum Frame w/ Stainless Steel Door Handles, complete hardware & accessories (COA Office)
- b. Supply and Installation of Vinyl Frosted Sticker on glass door and partition as indicated in the plan
- c. Supply & Installation of floor finishes:
 - 600mm x 600mm Ceramic Floor Tiles Porcelain Finish (CHR Office, COA Office, COA Records Room, Building Admin & Network Office, Data/Network Room, RIMT Records Rooms, Hallway, Elevator Lobby)
 - 300mm x 300mm Vinyl Floor Tiles at the Hallway for floor raceway as specified in the plan
- d. Supply and Installation of Sunscreen Roller Shades at the Perimeter Glass Window at the COA Office
- e. Supply and Installation of indoor acrylic signages as specified in the plan
- f. Cleaning of existing glass door and windows

4. Painting Works

- a. Surface preparation of all painting works (sanding, application of putty, easy tite and primer)
- b. Painting of new drywall partitions
- c. Painting of existing drywall & CHB/masonry walls

- d. Painting of Fiber Cement Ceiling Board
- e. Painting of wooden doors and jambs (ducco finish)
- f. Painting of metal / wood surfaces (existing windows, diffusers, louvers, cornices, baseboards)

5. Electrical Works

- a. The service provider/ contractor is *required* to conduct site inspection together with the Building Administration and EFMD Engineer or SSS representative to determine the nature and extent of necessary works, materials, services and consider these essential and incidental requirement in the implementation of the project.
- b. The contractor shall be responsible for the thorough coordination with the concern parties and secure of all necessary work permits that maybe required for the project.
- c. All works shall be properly coordinated with the Building Owner or SSS representative to discuss all phases of the works/ activities.
- d. Any changes and/ or modifications of the materials specification and work orders shall be subject to discussion with involve parties to address any conflicts before proceeding to the said changes prior to the approval of the Building Owner and the SSS representative.
- e. Dismantle of *all* electrical wiring devices including FDAS devices, panels, conduits, wirings and other existing layout not necessary for the new office design/ layout. All dismantled materials shall be turned-over to the assigned SSS representative for proper safekeeping.
- f. Supply and installation of new electrical wiring materials for the power supply of Duplex Convenience Outlet, 3-prong, parallel slot with appropriate grounding wire for the UPS power outlet (white). Circuits home run shall be tapped to the UPS Distribution Panel, as indicated in the plan. (Note: ETRS outlet shall be mounted 1.2 meters above finished floor).
- g. Air-cons for COA office and for network room must be tap at Panel LP4A.
- h. Supply and Installation of new electrical wirings for the replacement of sub-feeder lines of panels PP4C and LP4C.
- i. Supply and installation of new electrical wiring materials for the power supply of Duplex Convenience Outlet, 3-prong parallel slot, for the normal power outlet (beige). Circuits home run shall be tapped to the existing panel as indicated in the plan.
- j. Supply and installation of new electrical wiring materials for the power supply of new lighting fixtures and switches including portable emergency lights and fire/exit signage.
- k. Supply and installation of new electrical wiring materials for the power supply of new exhaust fans.
- l. Supply and installation of other incidental materials relative to other related works and activities to complete the installation and shall be shouldered to the sole account of the contractor.
- m. Conduits, cable trays and boxes shall be installed with appropriate supports and fittings and shall be rigidly secured using appropriate materials. Panel directory shall be properly labeled.
- n. All areas affected during implementation of the project by chipping, dismantling, relocation works and other related activities shall be restored to original condition at the owner's satisfaction at no additional cost to the SSS.
- o. Supply of labor, materials and devices that are *essential* for the completion of the project, may it be mentioned or not in the Terms of Reference (TOR), specified or not in Bill of Quantity (BOQ) and proposed plan layout.
- p. Preparation and submission of blue print as-built plans in standard size (20inx30in) duly signed and sealed by the Professional Practitioners (Electrical Engineer).
- q. Testing and commissioning of electromechanical equipment and facilities and submission of the start-up operation test result of the installed air-conditioning units.

6. Structured Cabling Works

- Same specifications as 4th Floor Renovation except for the ff:

- a. Supply necessary materials, manpower, tools and technical personnel for the full implementation of the project
- b. Roughing-ins installed over the ceiling shall be 2" x 4" cable raceway

- c. Supply and cable pulling of cat5e-solid UTP cables for 8 voice and 8 data outlets from network cabinet to horizontal distribution (proposed workstation areas)
- d. Provision of Cat5e patch panels (1pc. for data; 1pc. for voice)
- e. All imported cabling components should be end to end brand and must be approved and evaluated by NCD prior to installation.
- f. Any exposed downpole going to network cabinet shall be cable raceways or equivalent
- g. Whenever necessary provide pull box of proper size and dimension although not indicated in the plan
- h. Any other materials necessary to complete the project shall be in the accountabilities of the contractor
- i. Termination, Testing, Labeling and Commissioning
- j. Turnover and Submission of As-Built Plan and Documentation
- k. Other conditions for cabling contractors/suppliers/installer:
 - Installed Cabling System should pass testing
 - In cases where new furniture are to be used by the branch and are still to be delivered, the required outlets are to be temporarily installed by the installer based on the old furniture & lay-out.
 - All temporary installations are to be finalized by the installer to the new furniture lay-out.

B. MATERIAL SPECIFICATIONS

PARTICULARS	DESCRIPTION	REMARKS
A. CEILING		
1. COA Office, Hallway, Open Space for Expansion & Elevator Lobby	600mm x 600mm x 16mm thk Fissured Type Acoustic Ceiling Board - Powder coated Aluminum Tee Runner Suspended Ceiling Frame	- Armstrong or approved equivalent - CMT Products or approved equivalent
2. COA Records Room, RIMT Storage, Storage Rooms & Network Room	6mm thk Fiber Cement Board on suspended light metal ceiling frame system - Powder coated Aluminum Tee Runner Suspended Ceiling Frame - 12mm x38mm Carrying Channel - 19mm x 50mm Double Furring - 25mm x 25mm Wall Angle	- Hardiflex , Flexboard or approved equivalent - CMT Products or approved equivalent - JEA or Maxsteel products or approved equivalent
B. FLOORING		
Including Surface Preparation		
1. Floor Finish (as indicated on the plan)	- 600mm x 600mm Ceramic Floor Tiles Porcelain Finish - 300mm x 300mm x 3mm Vinyl Floor Tiles including all profiles	- Arte. Sol Ceramica or any local and China made tiles available in the market - APO Floors, Kent Floors or approved equivalent (submit sample for approval)
C. DOORS AND GLASS PARTITIONS		
1. Glass Door GD-01 at COA Office	- Single leaf 1.0 m x 2.54 m, 12mm thk tempered clear glass door with transom on aluminum framing and FD100 top and bottom frame powder coated finish	-any supplier and fabricator submit sample for approval

<p>2. Glass Partition GP 01 at COA Office</p>	<p>- Frameless, 1.20 mx 2.54 m; 12mm thk tempered clear glass on FD100 top and bottom frame powder coated or analog finish as indicated in the plans</p> <p>-Complete with fittings, hardwares and accessories with stainless steel door handle and</p>	<p>-any supplier and fabricator submit sample for approval</p> <p>-GCC, Sentry, Ryobi brand for fitting and accessories or approved equivalent</p>
<p>3. WD-01 Supplies Room, RIMT Records Room, Data/Network Room</p>	<p>- 0.90 m x 2.10 m x 45 mm THK Flush Hollow Core Frame with Class A Marine Plywood Facing w/ Bottom Louver</p> <p>- 2” x 4” x 2.15m Height Solid Door Jamb</p>	<p>- Kiln Dried Tanguile Wood Treated w/ Anti-Termite Solution</p>
<p>4. WD-02 Supplies Room, RIMT Records Room, Data/Network Room (with view glass)</p>	<p>- 0.90 m x 2.10 m x 45 mm THK Flush Hollow Core Frame with Class A Marine Plywood Facing w/ View Glass and Bottom Louver</p> <p>- 2” x 4” x 2.15m Height Solid Door Jamb</p> <p>- Stainless Steel Cylindrical Knob Entrance Lock</p> <p>- 3” x 3” Stainless Steel Heavy Duty Ball Bearing Hinges</p>	<p>- Kiln Dried Tanguile Wood Treated w/ Anti-Termite Solution</p> <p>- Hit, Yale, Ryobi or approved equivalent</p>

D. ARCHITECTURAL FINISHES / SPECIALTY WORKS

<p>1. Sunscreen Roller Shades</p>	<p>Hardwares and Mechanism:</p> <ul style="list-style-type: none"> - Roll-up Polyester/Polymer Shade - Chain Operated roller system with #10 plastic bead chain operating loop - Universal mounting brackets (includes hardwares and accessories). - Provide headrail where applicable. - Extruded aluminum roller tube made with alloy 6063-T5 Standard Roll - (White Color – Series 5000) <p>Sunscreen Fabric Specifications:</p> <ul style="list-style-type: none"> - Composition : 30% Polyester, 70% PVC - Openness Factor : 1%; Width : 200cm / 250cm; Length : Approx. 30m/roll; Thickness : 1.08mm; Weight: 810g/m2 ±5%; Tensile Strength : warp 291.5kg/ weft 100.3kg; Tearing Strength : warp 10.9kg /weft 5.8kg; UV Blockage : 98%; Fire Rating : U.S.A. NFPA 701; Color Fastness (AATCC16-2003): Class 4.5; Environmental Certifications : Oeko-Tex ® Standard 100 	<p>- Sun Pro or approved equivalent (submit sample for approval)</p>
<p>2. Indoor Signage</p>	<ul style="list-style-type: none"> - Acrylic Sheet Signage 	<p>As indicated on the plan</p>
<p>3. Frosted Vinyl Sticker</p>	<ul style="list-style-type: none"> - 3M Products or approved equivalent 	<p>Submit sample for approval</p>

E. PAINTING WORKS

Including Surface Preparation (sanding, application of putty, easy tite and primer)

1. Drywalls / Acoustic Ceiling Board - New Wall/Ceiling	- 1 coat Primer paint - Gypsum Putty - 2 coat Semi-gloss Latex Paint	- Davies, Boysen or approved equivalent
- Existing Wall/Ceiling	- 2 coat Semi-gloss Latex Paint	- Davies, Boysen or approved equivalent
2. Masonry Wall / Columns	- 2 Coats Semi-Gloss Latex Paint	- Davies, Boysen or approved equivalent
3. Fiber Cement Ceiling Board	- 1 coat Primer paint - Gypsum Putty - 2 coat Semi-gloss Latex Paint	- Davies, Boysen or approved equivalent
4. Wood Doors & Jamb	- Ducco fin., 2 coat Lacquer Primer Surfacer - Lacquer Spot Putty - 2 coat Clear Gloss Lacquer paint	- Davies, Boysen or approved equivalent
5. Steel / Metal surfaces	- 1 coat Epoxy Primer Gray - 2 coat Quick Drying Enamel paint	- Davies, Boysen or approved equivalent

F. ELECTRICAL WORKS

GENERAL CONDITIONS

- All electrical works shall comply with the plan and specification in accordance with the latest edition of the Philippine Electrical Code (PEC).
- The contractor shall be responsible for the coordination in securing all necessary permits and requirements in the renovation works.
- Rough-in layout concealed between walls and exposed above ceiling shall be IMC and/or Polyvinyl Chloride (PVC) pipes and properly secured with clamps/ mounting supports.
- PVC pipe fitting layout shall be provided with appropriate PVC adapter with locknut and glued with PVC solvent and properly anchored with clamps/ supports.
- Minimum size of conduit to be used shall be 15mm and 20mm diameter for IMC and PVC, respectively.
- Minimum size of conduit for long runs exceeding 270° bends shall be 20mm diameter and pull box shall be provided as necessary.
- Color coding for wiring installations shall be as follows:
 - For Normal Power Circuits - Line 1 - Black wire, 230 VAC
Line 2 - Red wire
Ground - Green wire
 - For UPS Power Circuits - Line 1 - White wire, 230 VAC
Line 2 - White wire
Ground - Green wire
- Color coding for receptacle outlet device plate covers shall be follows:
 - For Normal Power Circuit - Beige color
 - For UPS Power Circuits - White color
- All new wiring installations shall be tested and measured parameters shall be recorded and submitted accordingly.
- Receptacle outlets shall be installed 300mm above finished floor level.
- Labeling / marking for the proposed branch circuit as indicated in the drawing and panel board directory prior to turnover to the owner.
- All materials and equipment to be use shall be brand new and must be of the approved type and intended application.

- Prepare load schedule for all new installations, if necessary incorporate with the existing load schedule and provide legible markings between new and existing schedule of load.

MATERIAL SPECIFICATIONS

1. CONDUITS & FITTINGS

Materials	Specifications
a. PVC Pipe b. Flexible Conduit with Straight Connector	20mmØ, 25mmØ, 50mmØ PVC Pipe 20mmØ Flexible Conduit

2. BOXES / GUTTERS WITH COVERS

Materials	Specifications
a. Junction Box b. Utility Box	2” x 4”, steel sheet gauge 16 (4X2) Deep Type , GA #18

3. WIRES / CABLES & DEVICES

Materials	Specifications
a. 14.0 mm ² , 8.0 mm ² , 5.5 mm ² , 3.5 mm ² THHN/THWN	Stranded wire PVC insulated, nylon jacketed, Moisture and Heat Resistant, 600V, 90°C maximum operating temp., Lead Free, Gasoline Resistant, Flame Retardant
b. Convenience outlet (for UPS power)	Duplex, 15Amp, 230VAC, 3-prong, parallel slot, complete with white plate and cover
c. Convenience outlet (for Normal power)	Duplex, 15Amp, 230VAC, 3-prong, parallel slot, complete with beige plate and cover
d. Convenience outlet (for Portable Emergency / Exit Lights)	Single Outlet, 230VAC, parallel slot, complete with plate and cover
e. Switch	Single pole, 15Amp, 230VAC, 60Hz, complete with plate and cover (for one, two & three gang) Three-way switch, 230VAC, 60Hz, complete with plate and cover
f. LED Panel Light	Recessed Panel Type Lighting Fixture, 1200x300, 24W, 220V Recessed Panel Type Lighting Fixture, 1200x600, 32W, 220V
g. Downlight Fixture	Downlight, 150Ø Round Panel Type Lighting Fixture, 18W, 220V
h. Rechargeable Portable Emergency Light	10W, 6Vdc with back-up battery rechargeable, LED Bulb

i. Exit & Fire Exit Signage	5W, 6Vdc with back-up battery rechargeable, LED Bulb
j. Exhaust Fan	Tubular Type Exhaust Fan, Ceiling Mounted, 40W, 230Volts, 60Hz

5. CIRCUIT BREAKERS/PANEL

Materials	Specifications
a. PP4C	Main: 200AT, 3P, 230V, 32kAIC Branches: 1- 70AT, 3P, 230V, 25kAIC 5- 60AT, 3P, 230V, 25Kaic Bolt-on, Surface Mounted, NEMA-1
b. LP4C	Main: 70AT, 3P, 230V, 18kAIC Branches: 12- 20AT, 2P, 230V, 25kAIC Bolt-on, Surface Mounted, NEMA-1

6. CONDUIT SUPPORTS & OTHER MISCELLANEOUS & INCIDENTAL MATERIALS REQUIRED TO COMPLETE THE INSTALLATION

Materials	Specifications
a) Conduit support	Threaded bar with Grip Anchor
b) Conduit clamp	U-bolts/ strapped
c) Mounting of conduit	Angular bar, 1 ¼' x 1 ¼" x ¼"

STANDARD OF MATERIALS

All materials to be used in this installation shall be of high quality, free to any defect and of proven acceptability for the purpose it is intended for application. It shall conform to the latest applicable standards of the following:

- Philippine Electrical Code
- ASTM and NSC
- PEC and NEC

- Raceways, Conduit Pipes and Fittings

Polyvinyl Chloride (PVC) PVC conduits conforming to recognized standards for conduit as manufactured by Matsushita or approved equal.

Outlet Boxes and Covers

Terminations of pipes to outlet boxes shall be provided with suitable fitting and other devices especially designed for the purpose.

Receptacles : 2" x 4" x 2.5"

Pull Boxes : depends on the number of conductor to occupy the boxes

- Conductors, Wires and Cables

All wires and cables shall be copper, soft drawn and annealed with ninety-eight (98%) percent conductivity. For power systems, the conductors shall be thermoplastic and insulated to withstand a working pressure rated at 230 Volts, THHN/THWN type as indicated in the drawings. The feeder lines to panel boards shall be heat and moisture resistant, with size as indicated in the drawings.

The minimum size to be used in the installation shall be #3.5 mm sq. except for the controls where #2.0 mm sq. may be allowed. All conductors from sizes of #3.5 mm sq. or larger shall be stranded for additional flexibility while in transit inside pipe. All wires and cables described above shall be of reputable manufactures.

- Electrical and Wiring Devices

Wall Receptacles shall be of conventional type with an ampere rating of 15A, 230V, duplex, flush mounted. The mounting height shall be 300 mm above floor finish. It shall be as manufactured by National, Jimbo, Toshiba or approved equal.

Wall Plates for Switches and Receptacles

Wall plates for receptacles, in regards to colors shall be the sole choice of the Engineer. The brand shall be the same as specified above.

- Standard of Workmanship

The workmanship required in this section shall be the generally accepted engineering practice standard of safety. Defective workmanship shall be redone outright without extra cost to the Owner. Conduit installations, boxes, fittings and accessories shall conform to the requirements of the Philippine Electrical Code and other standards required locally.

During installation, due precautions shall be observed to protect the conduit and thread from mechanical injuries. The conduit ends shall be sealed in approved manner during the installation whenever the work is interrupted.

Conduit shall be checked for freedom from obstruction by pulling galvanized wire through the entire run of the conduit. The galvanized wire shall be maintained inside the pipe until the conductors have been pulled permanently. Termination boxes for conduits shall be free from dirt and other debris which may cause obstructions.

All joints between lengths of conduit shall be water tight with red lead paints or other approved sealing agent.

Conduit shall be held firmly on pipe termination by a pair of locknut and bushing. All outlets shall be truly centered, plumb and leveled. Any discrepancy on outlet location between the electrical plans and the architectural plans shall be called to the attention of the Engineer.

Wiring method in general shall be installed inside rigid steel conduit as required in the plan; no such wire shall be pulled inside the pipe if the conduit system is not complete in all aspect, so that the conductor will be protected from damages and abrasion.

Conductors terminated in any kind of outlet box shall have at least 150 mm of wire extended free from the box as allowance for splicing. Color coding shall be observed throughout the installation to provide easy identifications.

Installation of lighting fixtures, wall mounted receptacles and switches shall be given due care as to prevent contact of live wire parts to respective fixtures.

Conductor joints or splices will only be allowed in boxes and should be properly insulated by means of a wire nut fitted to the size of conductor being joined. Splices will never be tolerated inside pipe.

- Material Testing and Workmanship

Grounding - All exposed non-current carrying parts of Electrical Equipment and apparatus shall be properly grounded by means of ground rod driven one (1) meter below the ground level or connect to existing cold water pipe line. All metal conduit system and other parts required at ground potential shall be efficiently grounded. All panel boards' cabinet shall likewise be solidly grounded.

Materials and Workmanship Tests - All wiring system has to be tested for shorts and grounds after the installation has been completed. The Contractor shall furnish all necessary apparatus and testing equipment and will have to make good whatever deficiencies may be found. Test shall be conducted in the presence of the authorized representative of the Owner or the Engineer.

- Guarantee

All materials and accessories furnished/installed under this part of the specifications shall be guaranteed for a period of one (1) year from date of acceptance thereof, and materials and equipment furnished shall be free from any defects in the materials, workmanship and design. At any time within one year after acceptance and upon proper notice the Contractor shall rectify any and all deficiencies including replacement of parts or the entire units without additional cost to the Owners, if such deficiencies have been caused directly or indirectly by inferior materials, faulty workmanship and/or defective design or parts. Expendable items are included in this one year guarantee. During the guarantee period the Contractor shall perform free monthly inspection for the proper and efficient operation of the electrical system.

G. STRUCTURED CABLING WORKS – As specified on plan

Materials and work deemed necessary to complete the work but not specifically mentioned in the specifications, working drawings or in the other contract documents are inferred, and shall be supplied and installed by the contractor without extra cost to the owner. Such material shall be of the highest quality available, installed and applied in workmanlike manner at prescribed or appropriate locations.

2. VARIOUS IMPROVEMENT AT SSS BAGUIO (INFO KIOSK, ELECTRICAL ROOM AND VAULT AT THE GROUND FLOOR)

A. SCOPE OF WORK

1. Site Preparation

- a. Mobilization / Demobilization
- b. Temporary Facilities, Protective Covering and Board-up/Site Enclosure, Safety Signage
- c. Demolition/Dismantling Works which include Wall Partitions, Doors, Windows, Ceiling, Cabinets and other structures affected by the renovation works
- d. Hauling & Disposal of Debris & Waste Materials

2. Carpentry Works

- a. Supply and installation of 6mm thk Fiber Cement Ceiling board (Electrical Room, Vault and Info kiosk)
- b. Supply & Installation of Wooden Doors WD-01

3. Architectural/Specialty Works

- a. Supply & Installation of 600mm x 600mm Ceramic Floor Tiles Porcelain Finish (Info kiosk)
- b. Supply & Installation of 600mm x 600mm Ceramic Floor Tiles Porcelain Finish (Electrical and Vault Room)
- c. Supply & Installation of Glass Door w/ transom, GD-01 800 x 2600mm 1 Leaf Door w/ Transom w/ 12mm thk Temp. Glass on Analok Alum. Fr. (GF SSIT Entrance) w/ Stainless Steel Door Handles, Complete w/ Patch Fittings, hardware & accessories (Info Kiosk)
- d. Supply & Installation of Steel Door Aluminum Roll-Up Security Grills 5/6" Ø Solid Horizontal Aluminum Rods Spaced @ 2 1/2" O.C. 5/8" Vertical Aluminum Links spaced @ 9" O.C. complete with accessories at Info kiosk.

- e. Supply & Installation of 900 x 2150 mm steel Door Flush Hollow Core Steel Door w/ Lever Type Lockset & Dead Bolt & Bottom Louver, complete w/ hardware and accessories at Vault Room.
- f. Supply & Installation of Wood Door Flush Hollow Core wood Door w/ Cylindrical Lockset & Door Closer, complete w/ hardware & accessories at Electrical Room.
- g. Supply & Installation of Glass Store Front 6mm Tempered Glass on analog aluminum frame 0.800m x 0.360m and 1.150m x 2.560 m
- h. Supply and Installation of Vinyl Frosted Sticker on glass door and partition as indicated in the plan
- i. Cleaning of existing glass door and windows

4. Painting Works

- a. Surface preparation of all painting works (sanding, application of putty, easy tite and primer)
- b. Painting of existing drywall & CHB/masonry walls
- c. Painting of Fiber cement board
- d. Painting of wooden doors and jambs (ducco finish)

5. Electrical Works

- a. The service provider/ contractor is required to conduct site inspection together with the Building Administration and EFMD Engineer or SSS representative to determine the nature and extent of necessary works, materials, services and consider these are essential and incidental requirement in the implementation of the project.
- b. All works shall be properly coordinated with the Building Owner or SSS representative to discuss all phases of the works/ activities.
- c. Any changes and/ or modifications of the materials specification and work orders shall be subject to discussion with involve parties to address any conflicts before proceeding of the said changes prior to the approval of the Building Owner and the SSS representative.
- d. Dismantle of all electrical/ mechanical materials and other existing layout not necessary for the new office design/ layout. All dismantled materials shall be turn-over to the assign SSS representative for proper safekeeping.
- e. Supply and installation of new 150mmØ Recessed type, Spun Alum., specular finish Pinlight with Semi-F concave glass cover with mounting ring with 9W LED bulb in white PC finished complete with essential wirings
- f. Re-utilize the existing outlets (Normal/UPS) at the Info Kiosk as indicated in the plan.
- g. Supply of labor, materials and devices that are essential to complete the project. may it be mention or not in the Terms of Reference (TOR), specified or not in Bill of Quantity (BOQ) and proposed plan layout.
- h. Any damaged incurred during the activity shall be restored / repaired by the Contractor at his own expense and shall be done in a satisfactory and approved manner. Paint dropping and other stains relative to the project shall be removed from all areas.

6. Structured Cabling Works

- Same specifications as 4th Floor Renovation except for the ff:
 - a. Roughing-ins installed over the ceiling shall be Cable Raceways (2" x 4" ..# 18 with cover) and (3" x 6" ..# 18 with cover) ,Metal Flexible Conduits and IMCs.
 - b. Provision of 4 -runs CAT5e solid UTP Cable embedded to 1 inch diameter IMC/ RSC from IDF to the building's MTTC or demarcation Panel

B. MATERIAL SPECIFICATIONS

PARTICULARS	DESCRIPTION	REMARKS
A. CEILING		
1. Info Kiosk, Electrical room and Vault room	6mm thk Fiber Cement Board on suspended light metal ceiling frame system	- Hardiflex , Flexboard or approved equivalent

	<ul style="list-style-type: none"> - Powder coated Aluminum Tee Runner Suspended Ceiling Frame - 12mm x38mm Carrying Channel - 19mm x 50mm Double Furring - 25mm x 25mm Wall Angle 	<ul style="list-style-type: none"> - CMT Products or approved equivalent - JEA or Maxsteel products or approved equivalent
B. FLOORING – Including Surface Preparation		
1. Floor Finish Info Kiosk, Electrical room and Vault room	- 600mm x 600mm Ceramic Floor Tiles Porcelain Finish	-Arte. Sol Ceramica or any local and China made tiles available in the market
C. DOORS AND GLASS PARTITIONS		
1. Glass Door GD-01 at Info Kiosk	- 800 x 2600mm 1 Leaf Door w/ Transom w/ 12mm thk Temp. Glass on Analok Alum. Fr.	-any supplier and fabricator submit sample for approval
2. Steel Door Aluminum Roll-Up SD-01 at Info Kiosk	- Steel Door Aluminum Roll-Up security Grills 5/6" Ø Solid Horizontal Aluminum Rods Spaced @ 2 1/2" O.C. 5/8" Vertical Aluminum Links spaced @ 9" O.C. complete with accessories as indicated in the plans	-any supplier and fabricator submit sample for approval
3. SD-02 at Vault Room	- 1000 x 2150mm Steel Door Flush Hollow Core wood w/ lever type lockset and deadbolt complete w/ hardware & accessories	-any supplier and fabricator submit sample for approval
4. WD-01 Electrical Room	- 1000 x 2150mm Wood Door Flush Hollow Core wood Door w/ Cylindrical Lockset & Door Closer with bottom louver, complete w/ hardware & accessories	- Kiln Dried Tanguile Wood Treated w/ Anti-Termite Solution
5. Glass Store Front	- 6mm Temp. Glass on Analok Aluminum Frame 800 x 360 mm (transom) and 1250 mm x 2560 mm	-any supplier and fabricator submit sample for approval
D. PAINTING WORKS – Including Surface Preparation (sanding, application of putty, easy tite and primer)		
Existing Wall/Ceiling	- 2 coat Semi-gloss Latex Paint (Moonlight by Davies)	- Davies, Boysen or approved equivalent
Masonry Wall / Columns	- 2 Coats Semi-Gloss Latex Paint	- Davies, Boysen or approved equivalent
Fiber Cement Ceiling Board	- 1 coat Primer paint - Gypsum Putty - 2 coat Semi-gloss Latex Paint (Moonlight by Davies)	- Davies, Boysen or approved Equivalent
Steel / Metal surfaces	- 1 coat Epoxy Primer Gray - 2 coat Quick Drying Enamel paint	- Davies, Boysen or approved Equivalent
Wood Doors & Jamb	- Ducco fin., 2 coat Lacquer Primer Surfacer - Lacquer Spot Putty	- Davies, Boysen or approved Equivalent

- 2 coat Clear Gloss Lacquer paint

F. ELECTRICAL WORKS

GENERAL CONDITIONS:

- All electrical works shall comply with the plan and specification in accordance with the latest edition of the Philippine Electrical Code (PEC).
- PVC pipe fitting layout shall be provided with appropriate PVC adapter with locknut and glued with PVC solvent and properly anchored with clamps/ supports.
- Color coding for wiring installations shall be as follows:
 - For Normal Power Circuits
 - Line 1 - Black wire, 230 VAC
 - Line 2 - Red wire
 - Ground - Green wire
 - For UPS Power Circuits
 - Line 1 - White wire, 220 VAC
 - Line 2 - White wire
 - Ground - Green wire
- All new wiring installations shall be tested and measured parameters shall be recorded and submitted accordingly.
- All materials and equipment to be use shall be brand new and must be of the approved type and intended application.

MATERIAL SPECIFICATIONS

1. CONDUITS & FITTINGS

Materials	Specifications
a. Flexible Metal Conduit	15mmØ
b. Locknut and Bushing	15mmØ

2. BOXES / GUTTERS WITH COVERS

Materials	Specifications
a. Junction Box with plate cover	PVC Octagonal deep type gauge #16

3. WIRES / CABLES & DEVICES

Materials	Specifications
a. 3.5mm ²	THHN/ THWN stranded wire, Lead free 150mmØ Recessed type, Spun Alum., specular finish Pinlight with Semi-F concave glass cover with mounting ring with 9W LED bulb in white PC Finished
b. Downlight	

STANDARD OF MATERIALS

All materials to be used in this installation shall be of high quality, free to any defect and of proven acceptability for the purpose it is intended for application. It shall conform to the latest applicable standards of the following:

- Philippine Electrical Code
- ASTM and NSC
- PEC and NEC

Conductors, Wires and Cables

All wires and cables shall be copper, soft drawn and annealed with ninety-eight (98%) percent conductivity. For power systems, the conductors shall be thermoplastic and insulated to withstand a working pressure rated at 230 Volts, THHN/THWN type as indicated in the drawings. The feeder lines to panel boards shall be heat and moisture resistant, with size as indicated in the drawings.

The minimum size to be used in the installation shall be #3.5 mm sq. except for the controls where #2.0 mm sq. may be allowed. All conductors from sizes of #3.5 mm sq. or larger shall be stranded for additional flexibility while in transit inside pipe. All wires and cables described above shall be of reputable manufactures.

Guarantee

All materials and accessories furnished/installed under this part of the specifications shall be guaranteed for a period of one (1) year from date of acceptance thereof, and materials and equipment furnished shall be free from any defects in the materials, workmanship and design. At any time within one year after acceptance and upon proper notice the Contractor shall rectify any and all deficiencies including replacement of parts or the entire units without additional cost to the Owners, if such deficiencies have been caused directly or indirectly by inferior materials, faulty workmanship and/or defective design or parts. Expendable items are included in this one year guarantee. During the guarantee period the Contractor shall perform free monthly inspection for the proper and efficient operation of the electrical system.

G. STRUCTURED CABLING WORKS – *As specified on plan*

Section VII. Drawings

Various Improvements at SSS Baguio (Info kiosk, Electrical room and Vault at Ground floor)

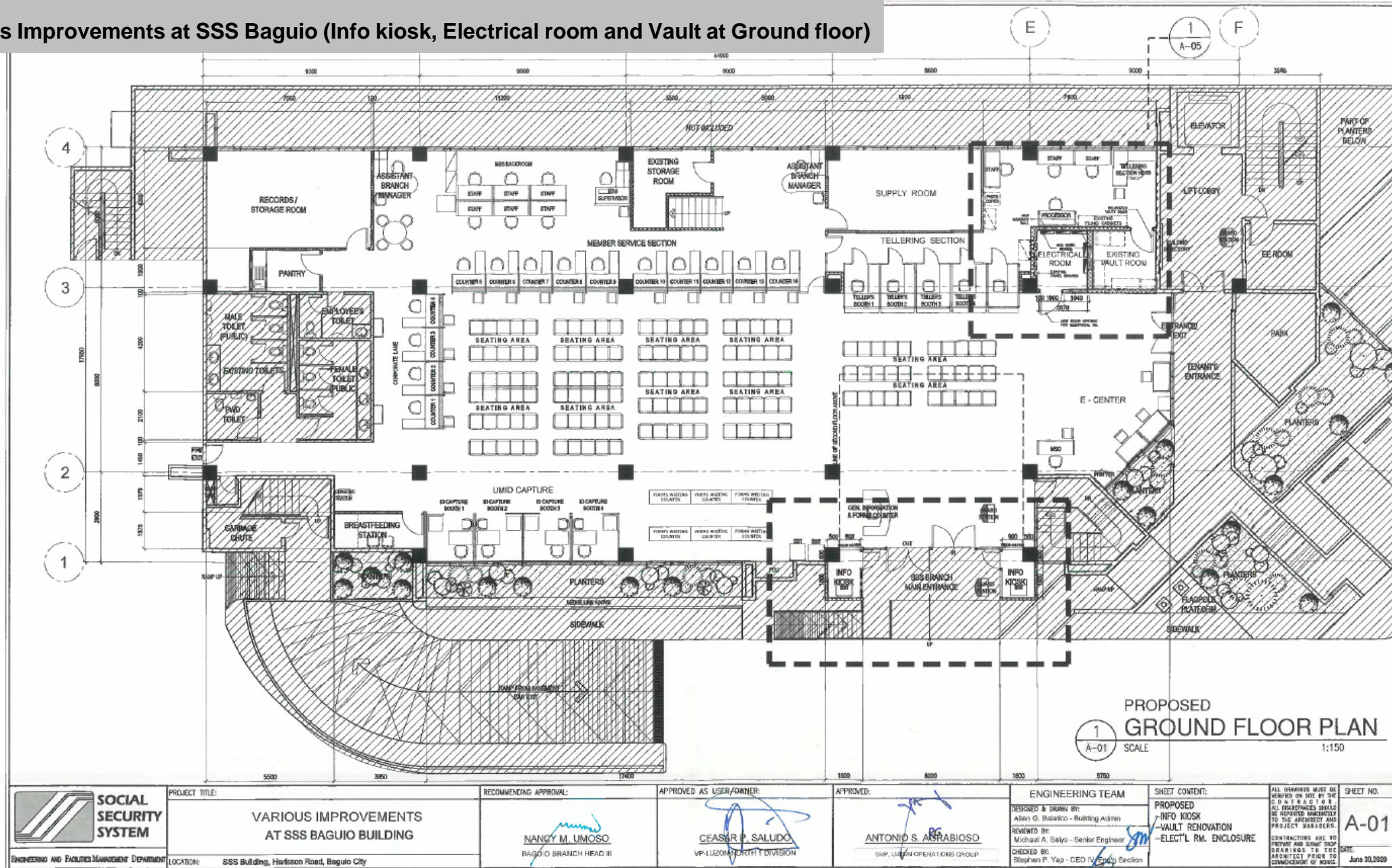

Renovation of 4th Floor (COA, RIMT Records Room, Network Room and Storage Room) and Various Improvements at Ground Floor (Info Kiosk, Electrical Room and Vault Room) at SSS Baguio Building

ofis

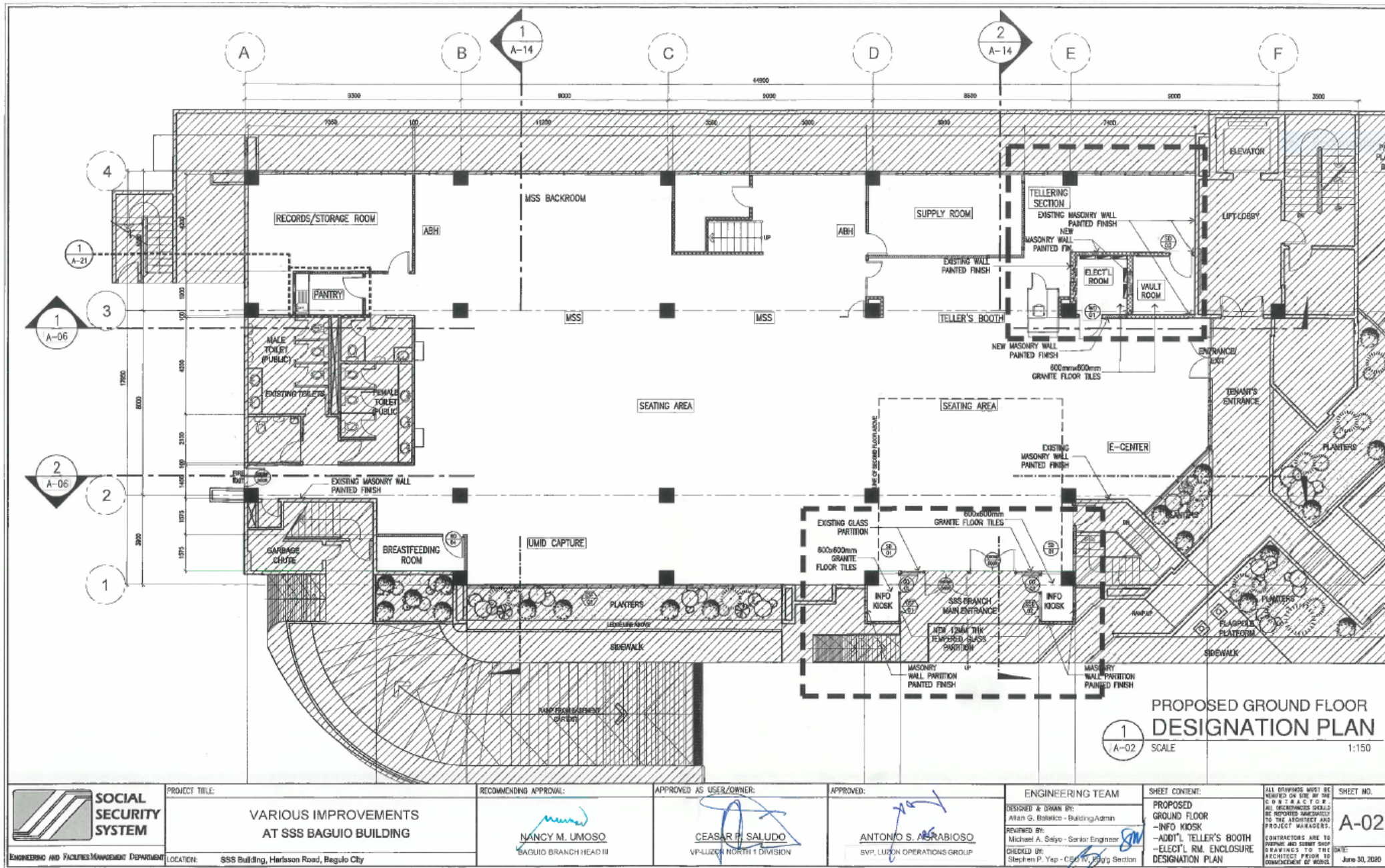

<p>SOCIAL SECURITY SYSTEM</p> <p>ENGINEERING AND FACILITIES MANAGEMENT DEPARTMENT</p>	<p>PROJECT TITLE:</p> <p>VARIOUS IMPROVEMENTS AT SSS BAGUIO BUILDING</p>	<p>RECOMMENDING APPROVAL:</p> <p><i>[Signature]</i> NANCY M. UMOSO BAGUIO BRANCH HEAD III</p>	<p>APPROVED AS USER/OWNER:</p> <p><i>[Signature]</i> CEASAR P. SALUDO VP-LUZON NORTH 1 DIVISION</p>	<p>APPROVED:</p> <p><i>[Signature]</i> ANTONIO S. ABRABIOSO SVP, LUZON OPERATIONS GROUP</p>	<p>ENGINEERING TEAM</p> <p>DESIGNED & DRAWN BY: Allan G. Balalico - Building Admin</p> <p>REVIEWED BY: Michael A. Salijo - Senior Engineer</p> <p>CHECKED BY: Stephen P. Yap - Chief W. Engg Section</p>	<p>SHEET CONTENT:</p> <p>PROPOSED GROUND FLOOR -INFO KIOSK -ADD'L TELLER'S BOOTH -ELECT'L RM. ENCLOSURE DESIGNATION PLAN</p>	<p>ALL DRAWINGS MUST BE VERIFIED ON SITE BY THE C.O.W. & A.C.T.G.P. ALL OBSERVATIONS SHOULD BE REPORTED IMMEDIATELY TO THE ARCHITECT AND PROJECT MANAGERS.</p> <p>CONTRACTORS ARE TO FORM AND GREAT SHOP DRAWINGS TO THE ARCHITECT PRIOR TO COMMENCEMENT OF WORK.</p> <p>DATE: June 30, 2020</p>	<p>SHEET NO.</p> <p>A-02</p>
	<p>LOCATION: SSS Building, Harlason Road, Baguio City</p>							

Renovation of 4th Floor (COA, RIMT Records Room, Network Room and Storage Room) and Various Improvements at Ground Floor (Info Kiosk, Electrical Room and Vault Room) at SSS Baguio Building

[Handwritten signature]

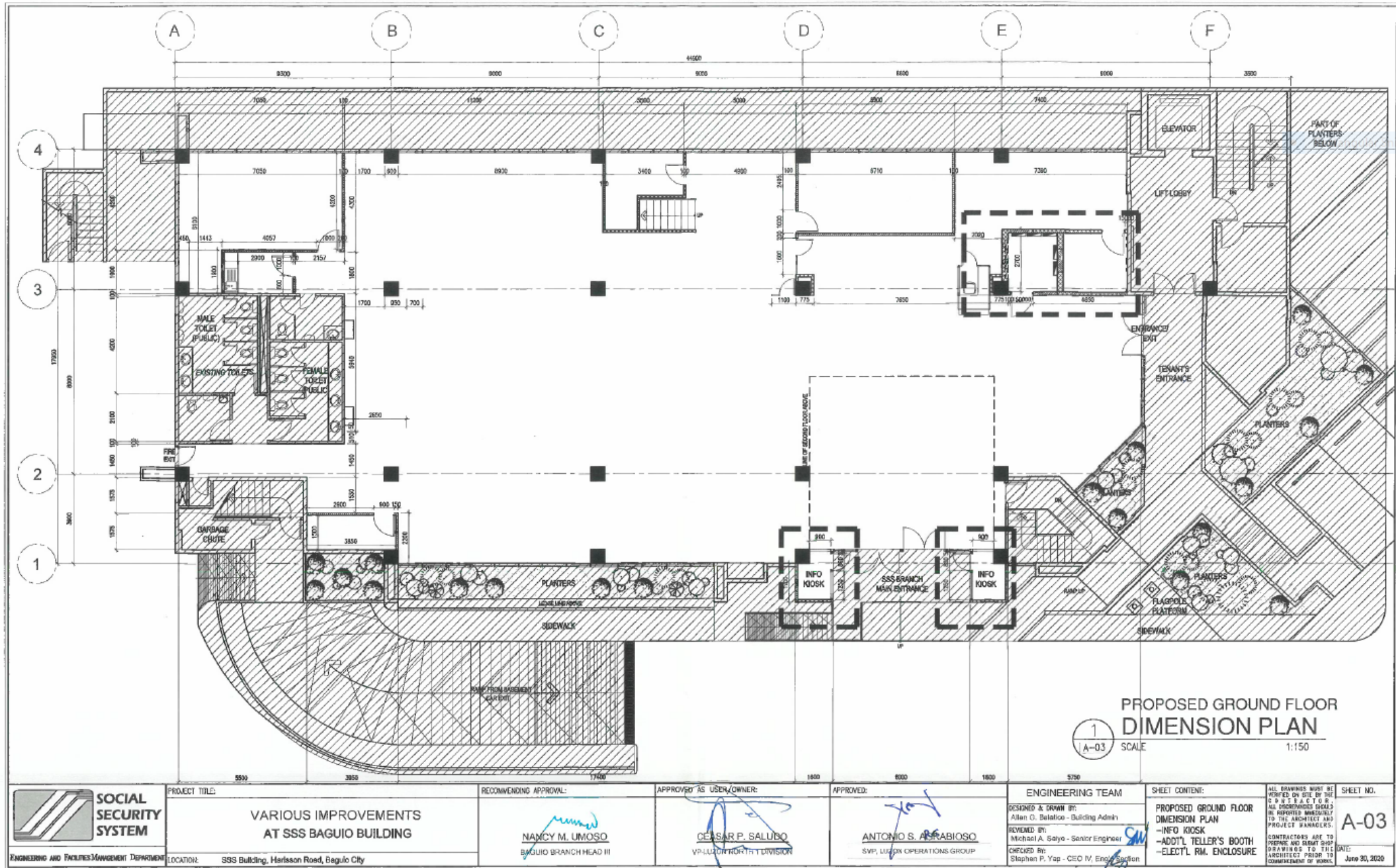

Renovation of 4th Floor (COA, RIMT Records Room, Network Room and Storage Room) and Various Improvements at Ground Floor (Info Kiosk, Electrical Room and Vault Room) at SSS Baguio Building

ofg

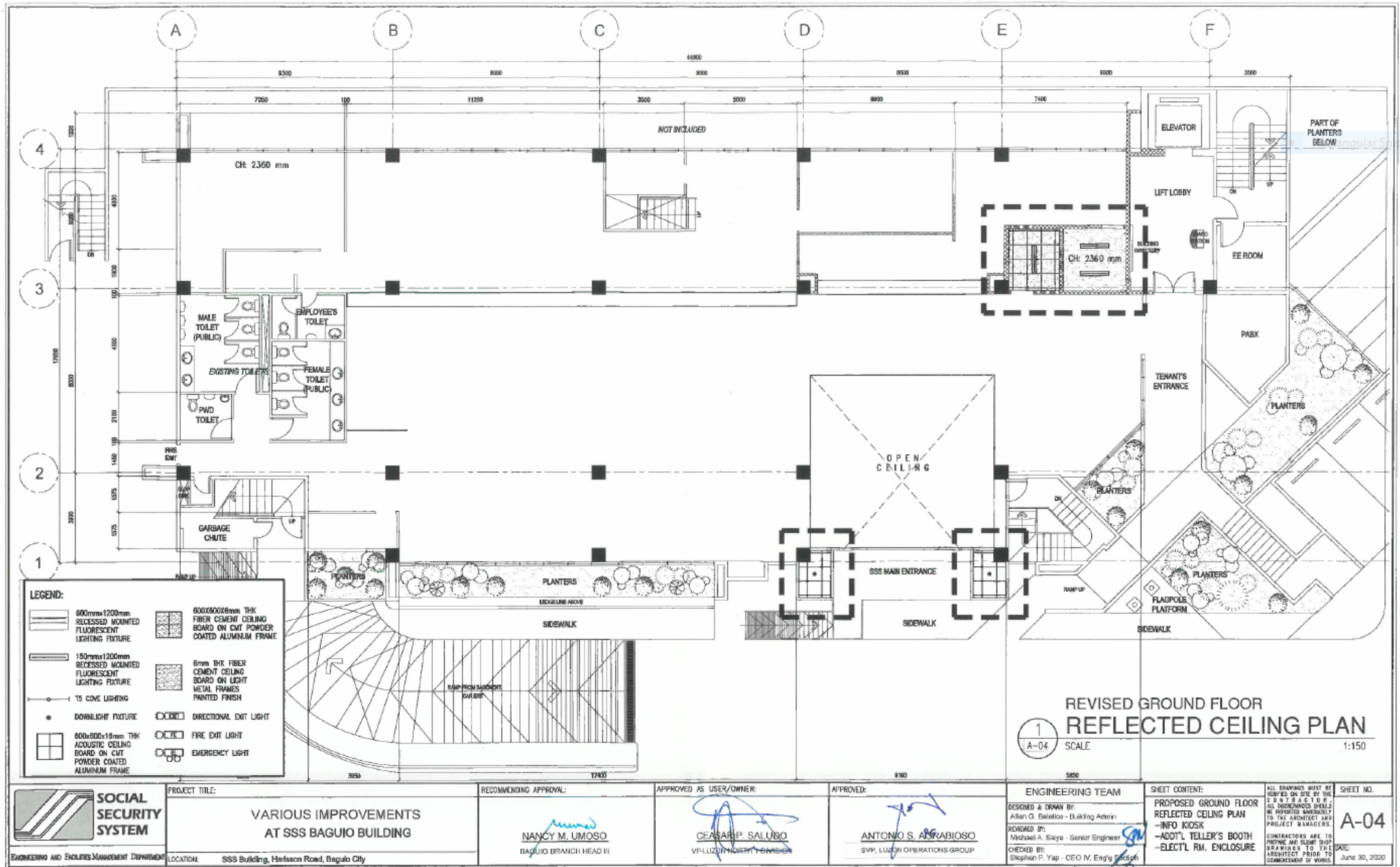

Renovation of 4th Floor (COA, RIMT Records Room, Network Room and Storage Room) and Various Improvements at Ground Floor (Info Kiosk, Electrical Room and Vault Room) at SSS Baguio Building

Handwritten signature

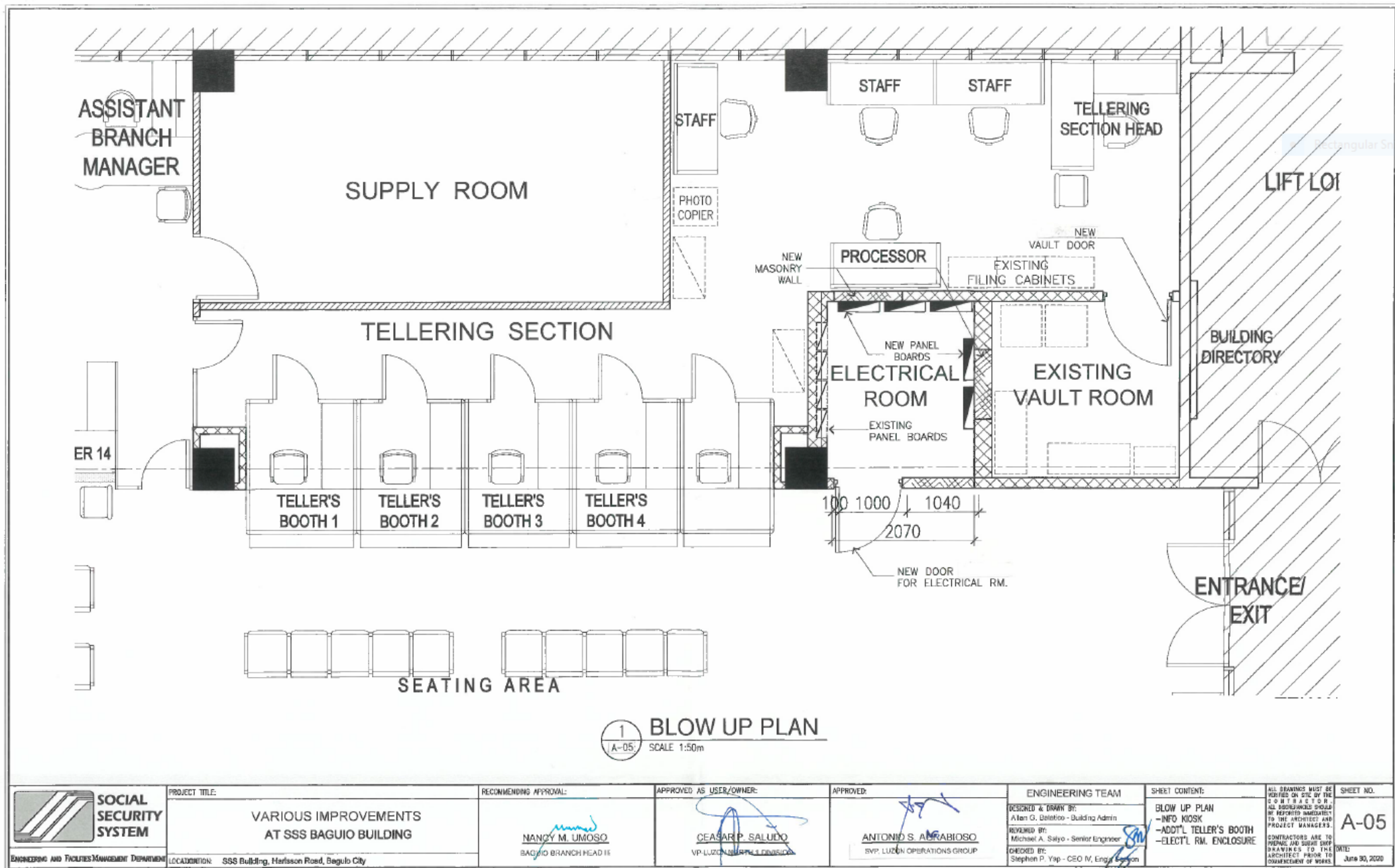

Renovation of 4th Floor (COA, RIMT Records Room, Network Room and Storage Room) and Various Improvements at Ground Floor (Info Kiosk, Electrical Room and Vault Room) at SSS Baguio Building

ofg

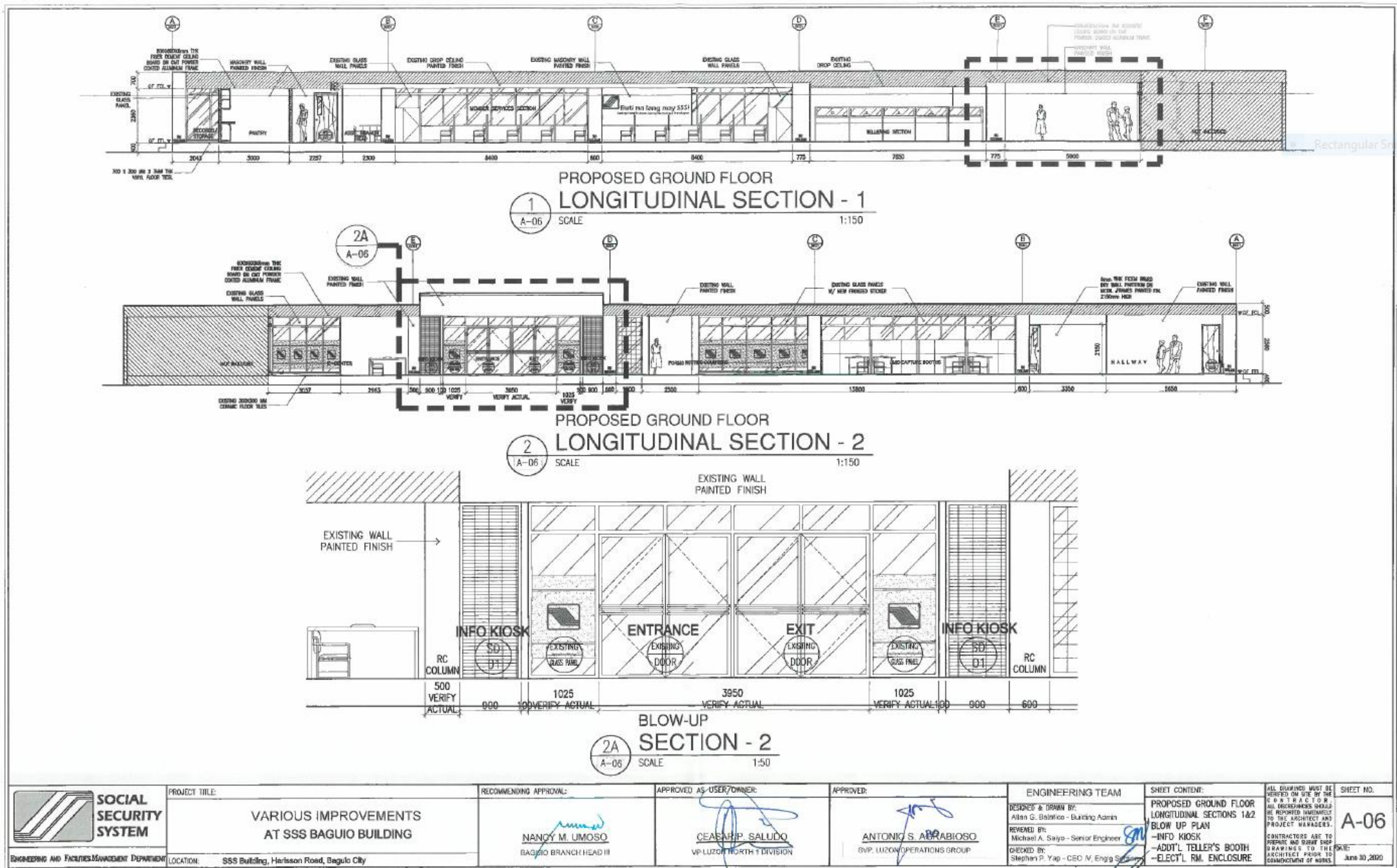

<p>SOCIAL SECURITY SYSTEM</p> <p>ENGINEERING AND FACILITIES MANAGEMENT DEPARTMENT</p>	PROJECT TITLE:	RECOMMENDING APPROVAL:	APPROVED AS USER/OWNER:	APPROVED:	ENGINEERING TEAM	SHEET CONTENT:	ALL DRAWINGS MUST BE VERIFIED ON SITE BY THE CONTRACTOR. ALL DIMENSIONS SHOULD BE REPORTED IMMEDIATELY TO THE ARCHITECT AND PROJECT MANAGERS.	SHEET NO.
	<p>VARIOUS IMPROVEMENTS AT SSS BAGUIO BUILDING</p> <p>LOCATION: SSS Building, Harrison Road, Baguio City</p>	<p>NANCY M. UMOSO BAGUIO BRANCH HEAD III</p>	<p>CEASAR P. SALUDO VP-LUZON NORTH DIVISION</p>	<p>ANTONIO S. ABRABIOSO SVP-LUZON OPERATIONS GROUP</p>	<p>DESIGNED & DRAWN BY: Allan G. Balofico - Building Admin</p> <p>REVIEWED BY: Michael A. Salayo - Senior Engineer</p> <p>CHECKED BY: Stephen P. Yap - CEO IV, Engrg. Supervisor</p>	<p>PROPOSED GROUND FLOOR LONGITUDINAL SECTIONS 1&2</p> <p>BLOW UP PLAN</p> <p>-INFO KIOSK</p> <p>-ADD'L TELLER'S BOOTH</p> <p>-ELECT'L RM. ENCLOSURE</p>	<p>CONTRACTORS ARE TO OBTAIN AND SUBMIT SHOP DRAWINGS TO THE ARCHITECT PRIOR TO COMMENCEMENT OF WORKS.</p>	<p>A-06</p> <p>June 30, 2020</p>

Renovation of 4th Floor (COA, RIMT Records Room, Network Room and Storage Room) and Various Improvements at Ground Floor (Info Kiosk, Electrical Room and Vault Room) at SSS Baguio Building

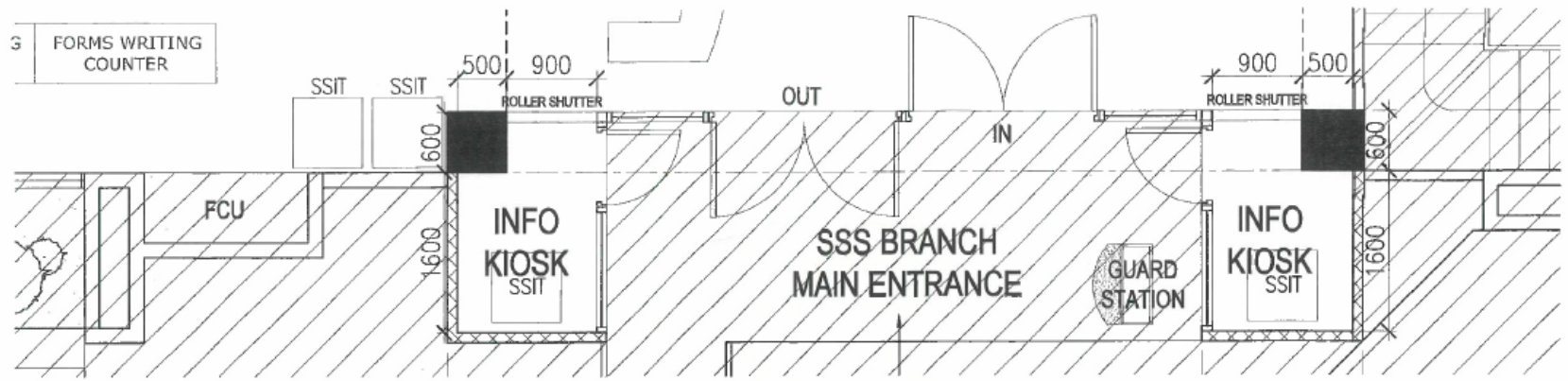

1
A-071 SCALE 1:50
INFO KIOSK BLOW-UP PLAN

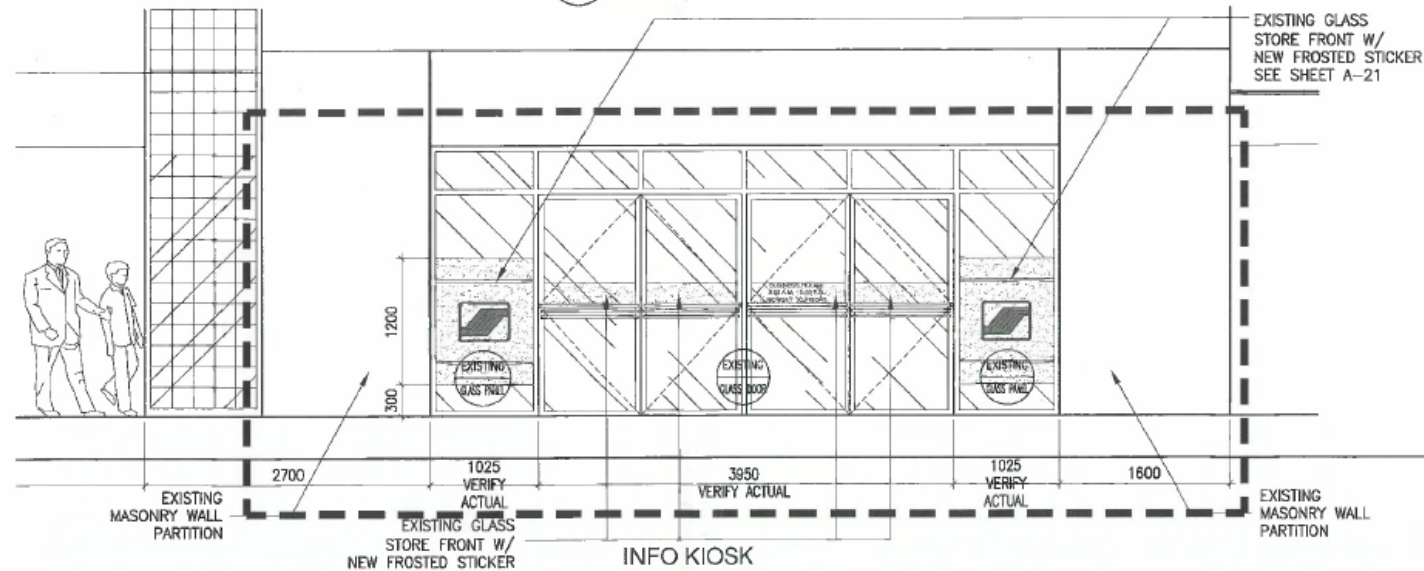

2
A-071 SCALE 1:50
INFO KIOSK FRONT ELEVATION

<p>SOCIAL SECURITY SYSTEM</p> <p>ENGINEERING AND FACILITIES MANAGEMENT DEPARTMENT</p>	<p>PROJECT/TITLE: VARIOUS IMPROVEMENTS AT SSS BAGUIO BUILDING</p>	<p>RECOMMENDING APPROVAL:</p> <p><i>Nancy M. Umoso</i></p> <p>NANCY M. UMOSO BAGUIO BRANCH HEAD III</p>	<p>APPROVED AS USER/OWNER:</p> <p><i>Cesar P. Saludo</i></p> <p>CEASAR P. SALUDO VP-LUZON NORTH DIVISION</p>	<p>APPROVED:</p> <p><i>Antonio S. Abrabioso</i></p> <p>ANTONIO S. ABRABIOSO SVP, LUZON OPERATIONS GROUP</p>	<p>ENGINEERING TEAM</p> <p>DESIGNED & DRAWN BY: Afan G. Balazon - Building Admin</p> <p>REVIEWED BY: Michael A. Sayo - Senior Engineer</p> <p>CHECKED BY: Stephen P. Yap - CEO IV, Eng'g Section</p>	<p>SHEET CONTENT:</p> <p>INFO KIOSK BLOW UP PLAN INFO KIOSK FRONT ELEVATION</p>	<p>ALL DRAWINGS MUST BE CHECKED ON SITE BY THE CONTRACTOR. ALL IMPROVEMENTS SHOULD BE REPORTED IMMEDIATELY TO THE ARCHITECT AND PROJECT MANAGERS.</p> <p>CONTRACTORS ARE TO PREPARE AND SIGN SHEET DRAWINGS TO THE ARCHITECT PRIOR TO COMMENCEMENT OF WORKS.</p>	<p>SHEET NO. A-07</p> <p>DATE: June 30, 2020</p>
	<p>LOCATION: SSS Building, Harrison Road, Baguio City</p>							

ofaz

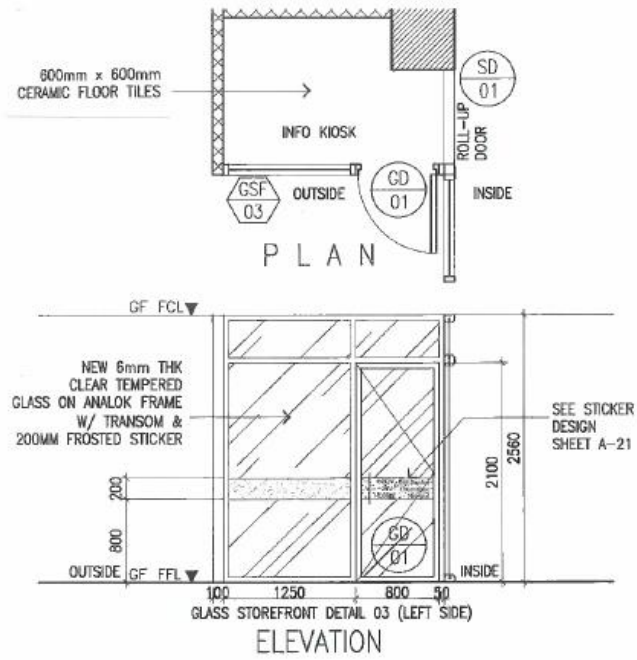

1 GLASS STOREFRONT DETAIL 01
A-08 SCALE 1:50

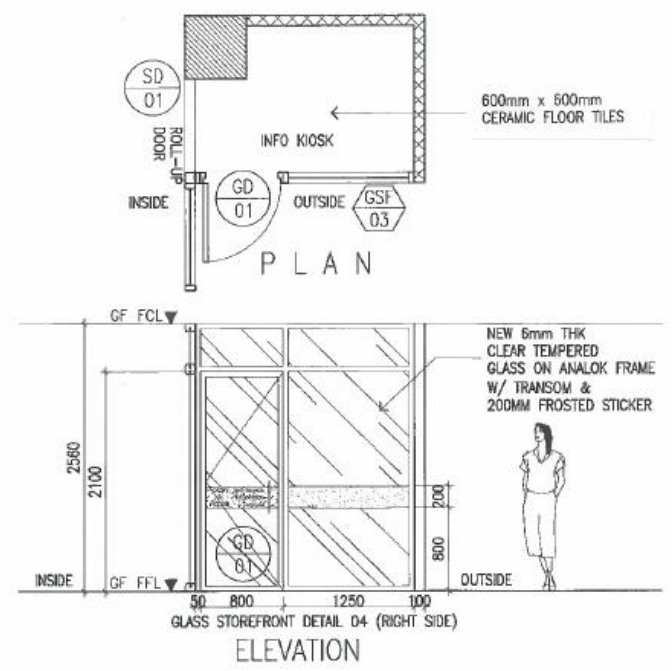

2 GLASS STOREFRONT DETAIL 02
A-08 SCALE 1:50

<p>SOCIAL SECURITY SYSTEM</p> <p>ENGINEERING AND FACILITIES MANAGEMENT DEPARTMENT</p>	PROJECT TITLE:	RECOMMENDING APPROVAL:	APPROVED AS USER/OWNER:	APPROVED:	ENGINEERING TEAM:	SHEET CONTENT:	ALL DRAWINGS MUST BE REVISION ON SITE BY THE CONTRACTOR. ALL UNDERPARTS SHOULD BE REPORTED IMMEDIATELY TO THE ARCHITECT AND PROJECT MANAGERS.	SHEET NO.
	<p>VARIOUS IMPROVEMENTS AT SSS BAGUIO BUILDING</p> <p>LOCATION: SSS Building, Harrison Road, Baguio City</p>	<p>NANCY M. UMOSO BAGUIO BRANCH HEAD III</p>	<p>CEASAR P. SALUDO VP-LUZON NORTH DIVISION</p>	<p>ANTONIO S. ALFABIOSO SVP, LUZON OPERATIONS GROUP</p>	<p>DESIGNED & DRAWN BY: Alan G. Balatoco - Building Admin</p> <p>REVIEWED BY: Michael A. Salayo - Senior Engineer</p> <p>CHECKED BY: Stephen P. Yap - CFO IV, Engrg Services</p>	<p>GROUND FLOOR INFO KIOSK GLASS STOREFRONT DET. 01 GLASS STOREFRONT DETAILS 02</p>	<p>CONTRACTORS ARE TO PROVIDE AND SUBMIT SHOP DRAWINGS TO THE ARCHITECT PRIOR TO COMMENCEMENT OF WORK.</p> <p>DATE: JAN. 17, 2020</p>	<p>A-08</p>

Handwritten signature

Rectangular St

<p>(SD 01)</p> <p>DESIGNATION: STEEL DOOR 01</p> <p>DESCRIPTION: ALUMINUM ROLL-UP SECURITY GRILLS</p> <p>3/8" SOLID HORIZONTAL ALUM. RODS SPACED @ 2 1/2" O.C., 3/8" VERTICAL ALUM. LINKS SPACED @ 9" O.C. COMPLETE w/ ACCESSORIES</p> <p>2 SETS REQ'D</p> <p>LOCATION: INFO KIOSKS</p>	<p>(SD 02)</p> <p>DESIGNATION: STEEL DOOR 02</p> <p>DESCRIPTION: FLUSH HOLLOW CORE STEEL DOOR w/ LEVER TYPE LOCKSET & DEAD BOLT & BOTTOM, LOUVER, COMPLETE w/ HARDWARES & ACCESSORIES</p> <p>1 SET REQ'D</p> <p>LOCATION: VAULT ROOM</p>	<p>(WD 01)</p> <p>DESIGNATION: WOOD DOOR 01</p> <p>DESCRIPTION: FLUSH HOLLOW CORE WOOD DOOR w/ CYLINDRICAL LOCKSET & DOOR CLOSER, COMPLETE w/ HARDWARES & ACCESSORIES</p> <p>1 SET REQ'D</p> <p>LOCATION: ELECTRICAL ROOM GROUND FLOOR</p>

2
A-09
SCHEDULE OF DOORS
 SCALE 1:50

	PROJECT TITLE:	RECOMMENDING APPROVAL:	APPROVED AS USER/OWNER:	APPROVED:	ENGINEERING TEAM	SHEET CONTENT:	SHEET NO.	
	VARIOUS IMPROVEMENTS AT SSS BAGUIO BUILDING	 NANCY M. UMOSO <small>BAGUIO BRANCH HEAD III</small>	 CEASAR P. SALUDO <small>VP-LUZON NORTH DIVISION</small>	 ANTONIO S. ARRIBAS <small>SVP, LUZON OPERATIONS GROUP</small>	<small>DESIGNED & DRAWN BY:</small> Allan G. Bataico - Building Admin <small>REVIEWED BY:</small> Michael A. Sayo - Senior Engineer <small>CHECKED BY:</small> Stephen P. Yap - CEO IV, Engrg SSS	SCHEDULE OF DOORS	<small>ALL DRAWINGS MUST BE VERIFIED ON SITE BY THE CONTRACTOR. ALL DISCREPANCIES SHOULD BE REPORTED IMMEDIATELY TO THE ARCHITECT AND PROJECT MANAGERS. CONTRACTORS ARE TO PREPARE AND SIGN SHOP DRAWINGS TO THE ARCHITECT PRIOR TO COMMENCEMENT OF WORKS.</small> DATE: June 30, 2020	A-09
<small>ENGINEERING AND FACILITIES MANAGEMENT DEPARTMENT</small>		<small>LOCATION: SSS Building, Harrison Road, Baguio City</small>						

Renovation of 4th Floor (COA, RIMT Records Room, Network Room and Storage Room) and Various Improvements at Ground Floor (Info Kiosk, Electrical Room and Vault Room) at SSS Baguio Building

ofaz

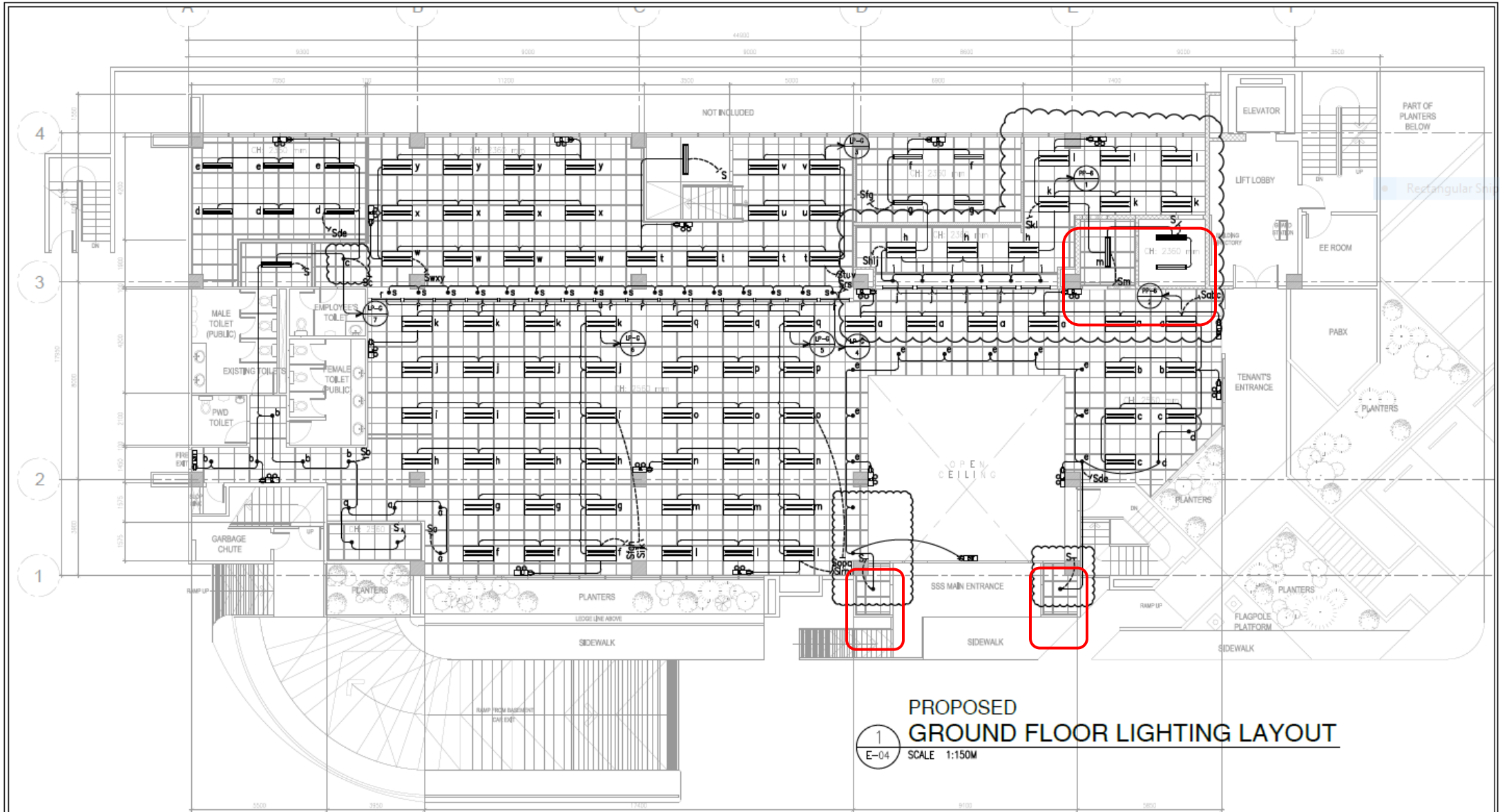

1
E-04
PROPOSED GROUND FLOOR LIGHTING LAYOUT
SCALE 1:150M

 ENGINEERING AND FACILITIES MANAGEMENT DEPARTMENT SOCIAL SECURITY SYSTEM	PROJECT TITLE PROPOSED RENOVATION OF SSS BAGUIO BRANCH AND NORTH LUZON CLUSTER LEGAL UNIT OFFICE	RECOMMENDING APPROVAL EDWIN B. MALIWAT	APPROVED BY: NESTOR R. SACAYAN	APPROVED AS USER/OWNER: JOSIE G. MAGANA	APPROVED FOR IMPLEMENTATION: MAY CATHERINE C. CIRIACO	ENGINEERING SECTION DESIGNED BY: C.F. Barican - Sr. Engineer, EMT-1 DRAWN BY: JC Taguinod - JO Engineer, EMT-1 REVIEWED BY: George N. Carreon - SSO V, EMT CHECKED BY: Stephen Yap - CEO IV, Eng'g.	SHEET CONTENT: -GROUND FLOOR LIGHTING LAYOUT	ALL DRAWINGS MUST BE CHECKED ON SITE BY THE CONSULTANT. ALL OBSERVATIONS SHOULD BE REPORTED IMMEDIATELY TO THE ARCHITECT AND PROJECT MANAGERS. CONTRACTORS ARE TO REVIEW AND SUBMIT SHOP DRAWINGS TO THE ARCHITECT PRIOR TO COMMENCEMENT OF WORKS.	SHEET NO. E-04 DATE R1 Dec 05, 2017
	LOCATION: Ground Floor & Fourth Floor, SSS Building, Harrison Road, Baguio City	DEPARTMENT MANAGER III - EFM	VP GENERAL SERVICES DIVISION	SVP LUZON OPERATIONS GROUP	SVP ADMINISTRATIONS GROUP				

Renovation of 4th Floor (COA, RIMT Records Room, Network Room and Storage Room) and Various Improvements at Ground Floor (Info Kiosk, Electrical Room and Vault Room) at SSS Baguio Building

ofag

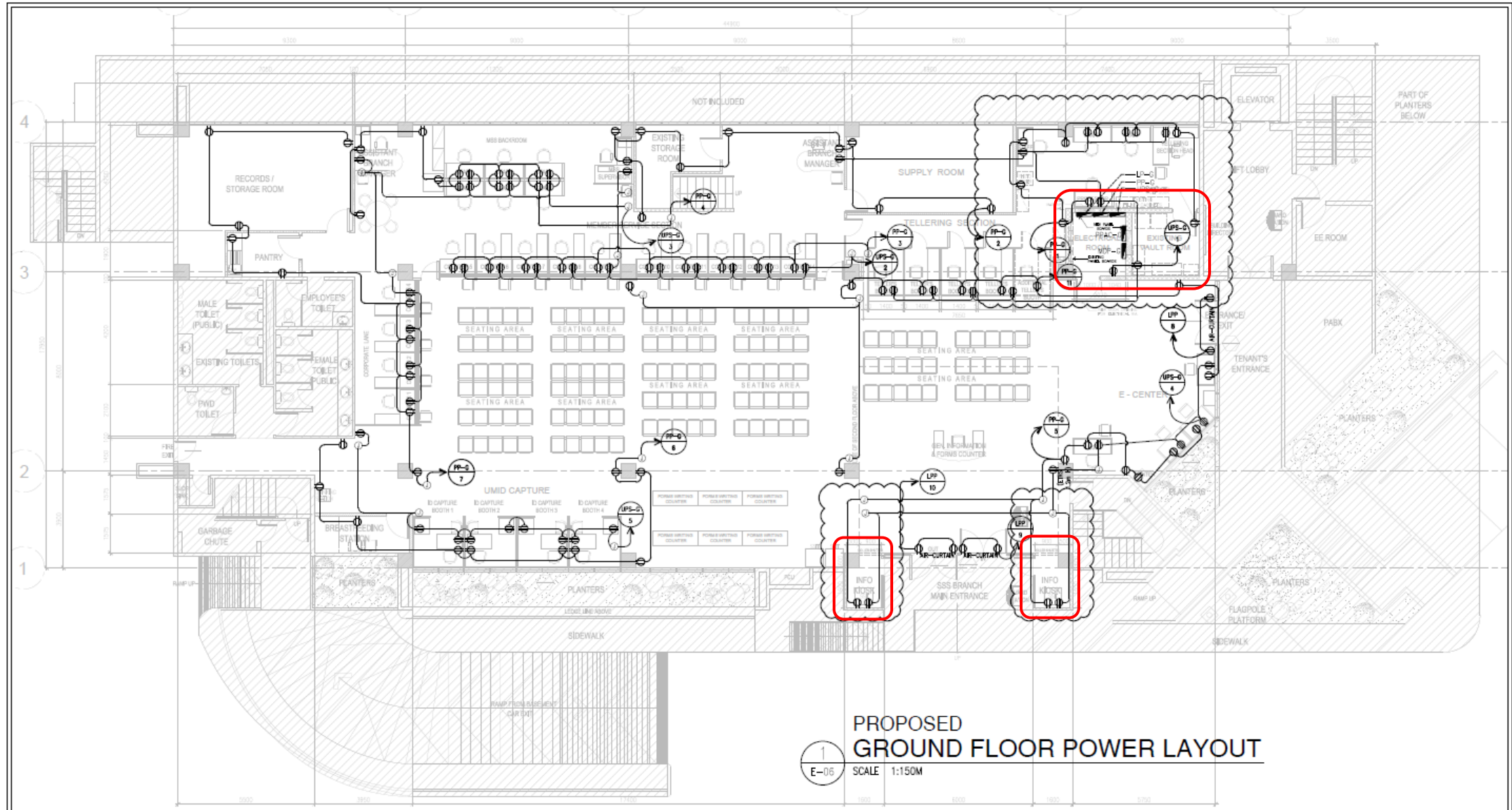



1
E-06 SCALE 1:150M
**PROPOSED
GROUND FLOOR POWER LAYOUT**

 ENGINEERING AND FACILITIES MANAGEMENT DEPARTMENT SOCIAL SECURITY SYSTEM	PROJECT TITLE PROPOSED RENOVATION OF SSS BAGUIO BRANCH AND NORTH LUZON CLUSTER LEGAL UNIT OFFICE	RECOMMENDING APPROVAL <u>EDWIN B. MALIWAT</u> <small>DEPARTMENT MANAGER III - EPMO</small>	APPROVED BY: <u>NESTOR R. SACAYAN</u> <small>VP GENERAL SERVICES DIVISION</small>	APPROVED AS USER/OWNER: <u>JOSIE G. MAGANA</u> <small>SVP LUZON OPERATIONS GROUP</small>	APPROVED FOR IMPLEMENTATION: <u>MAY CATHERINE C. CIRIACO</u> <small>SVP ADMINISTRATIONS GROUP</small>	ENGINEERING SECTION DESIGNED BY: C.F. Bancar - Sr. Engineer, EMT-1 DRAWN BY: JO Taguinod - JO Engineer, EMT-1 REVIEWED BY: George N. Carreon - SSO V, EMT CHECKED BY: Stephen Yap - CEO IV, Engg.	SHEET CONTENT: -GROUND FLOOR POWER LAYOUT	SHEET NO. E-06
	LOCATION: Ground Floor & Fourth Floor, SSS Building, Harisson Road, Baguio City	<small>ALL DRAWINGS MUST BE REVIEWED IN SITU BY THE CLIENT AND ALL REVISIONS SHALL BE INDICATED IMMEDIATELY TO THE ARCHITECT AND PROJECT MANAGERS.</small> <small>CONTRACTORS ARE TO PROVIDE AND GUARANTEE PROVISIONS TO THE ASSURETY PRIOR TO COMMENCEMENT OF WORKS.</small>	<small>DATE:</small> R1 Dec 05, 2017					

Renovation of 4th Floor (COA, RIMT Records Room, Network Room and Storage Room) and Various Improvements at Ground Floor (Info Kiosk, Electrical Room and Vault Room) at SSS Baguio Building

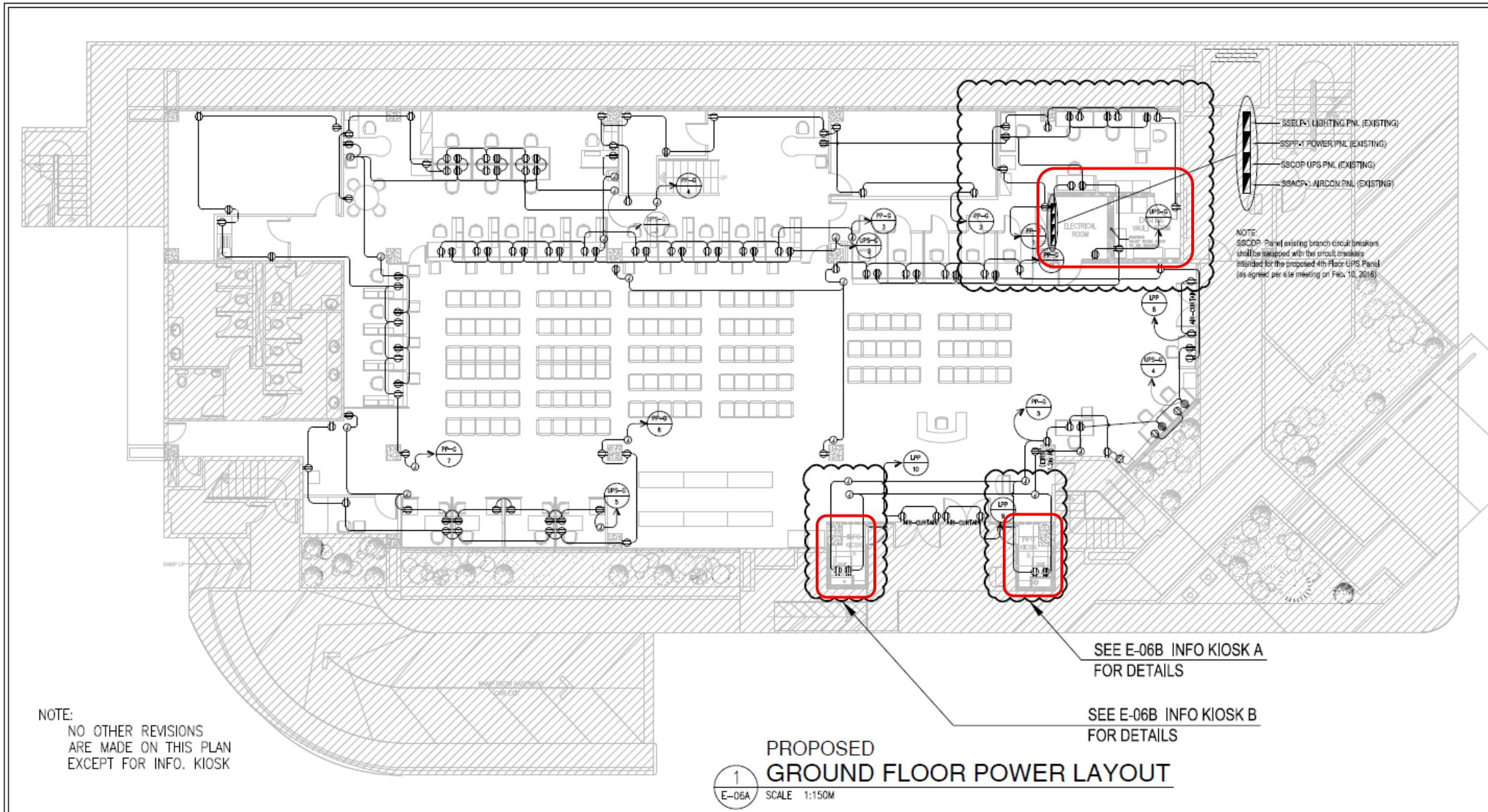
ofag



 ENGINEERING AND FACILITIES MANAGEMENT DEPARTMENT SOCIAL SECURITY SYSTEM	PROJECT TITLE: PROPOSED RENOVATION OF SSS BAGUIO BRANCH AND NORTH LUZON CLUSTER LEGAL UNIT OFFICE	RECOMMENDING APPROVAL: EDWIN B. MALIWAT DEPARTMENT MANAGER III - EFMD	APPROVED BY: NESTOR R. SACAYAN VP GENERAL SERVICES DIVISION	APPROVED AS USER/OWNER: JOSIE G. MAGANA SVP LUZON OPERATIONS GROUP	APPROVED FOR IMPLEMENTATION: MAY CATHERINE C. CIRIACO SVP ADMINISTRATIONS GROUP	ENGINEERING SECTION: DESIGNED BY: C.F. Bancar - Sr. Engineer, EMT-1 DRAWN BY: JC Taguinod - JO Engineer, EMT-1 REVIEWED BY: George N. Carreon - SSO V, EMT CHECKED BY: Stephen Yap - CEO IV, Engg	SHEET CONTENT: GROUND FLOOR POWER LAYOUT	ALL DRAWINGS MUST BE KEPT ON SITE OF THE CONTRACTOR. ALL DISCREPANCIES SHALL BE REPORTED IMMEDIATELY TO THE ARCHITECT AND PROJECT MANAGERS. CONTRACTORS ARE TO PROVIDE AND SUBMIT SHOP DRAWINGS TO THE ARCHITECT PRIOR TO COMMENCEMENT OF WORKS.	SHEET NO.: E-06A DATE: Feb 10, 2018
	LOCATION: Ground Floor & Fourth Floor, SSS Building, Harisson Road, Baguio City								



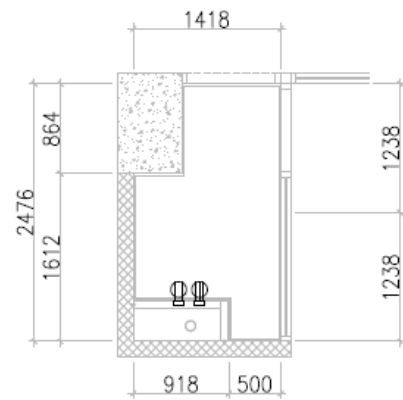

1
E-06B SCALE 1:50
**INFO KIOSK A
BLOW-UP PLAN**

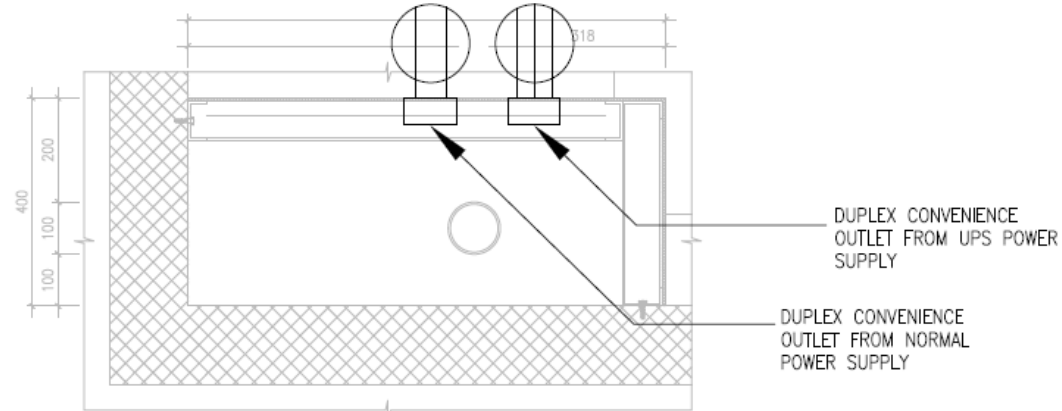

2
E-06B SCALE 1:10
**INFO KIOSK A
BLOW-UP DETAILS**

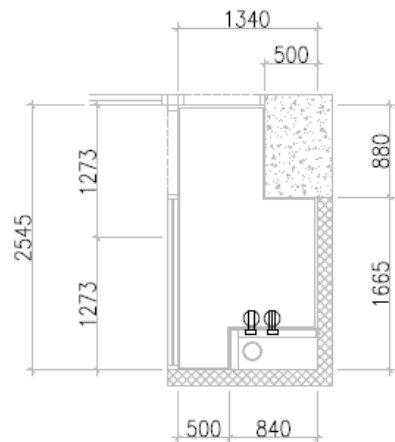

3
E-06B SCALE 1:50
**INFO KIOSK B
BLOW-UP PLAN**

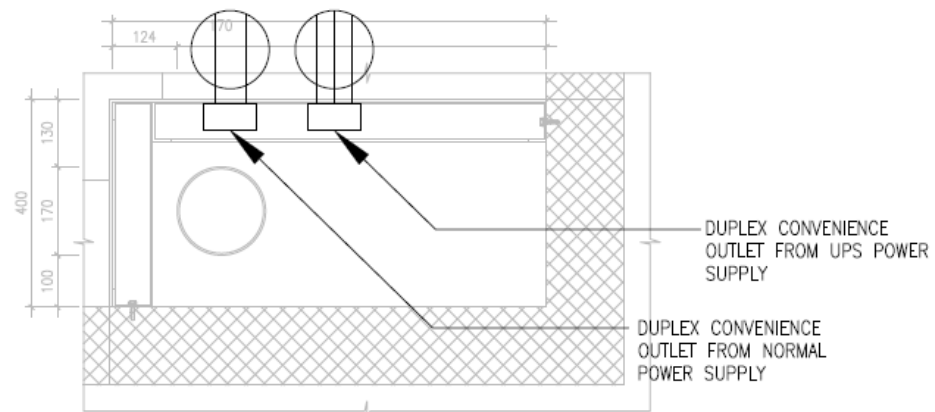

4
E-06B SCALE 1:10
**INFO KIOSK B
BLOW-UP DETAILS**

<p>ENGINEERING AND FACILITIES MANAGEMENT DEPARTMENT</p> <p>SOCIAL SECURITY SYSTEM</p>	<p>PROJECT TITLE:</p> <p>PROPOSED RENOVATION OF SSS BAGUIO BRANCH AND NORTH LUZON CLUSTER LEGAL UNIT OFFICE</p>	<p>RECOMMENDING APPROVAL:</p> <p><u>EDWIN B. MALIWAT</u></p> <p>DEPARTMENT MANAGER III - EFMD</p>	<p>APPROVED BY:</p> <p><u>NESTOR R. SACAYAN</u></p> <p>VP GENERAL SERVICES DIVISION</p>	<p>APPROVED AS USER/OWNER:</p> <p><u>JOSIE G. MAGANA</u></p> <p>SVP LUZON OPERATIONS GROUP</p>	<p>APPROVED FOR IMPLEMENTATION:</p> <p><u>MAY CATHERINE C. CIRIACO</u></p> <p>SVP ADMINISTRATIONS GROUP</p>	<p>ENGINEERING SECTION</p> <p>DESIGNED BY: C.F. Bancar - Sr. Engineer, EMT-1</p> <p>DRAWN BY: JC Taguinod - JO Engineer, EMT-1</p> <p>REVIEWED BY: George N. Carreon - SSO V, EMT</p> <p>CHECKED BY: Stephen Yap - CEO IV, Eng'g.</p>	<p>SHEET CONTENT:</p> <p>INFO KIOSK A BLOW-UP PLAN INFO KIOSK B BLOW-UP PLAN</p>	<p>ALL DRAWINGS MUST BE VERIFIED ON SITE BY THE CONTRACTOR AND ALL DISCREPANCIES SHOULD BE REPORTED IMMEDIATELY TO THE PROJECT AND PROJECT MANAGERS.</p> <p>CONTRACTORS ARE TO FURNISH AND SUBMIT SHOP DRAWINGS TO THE ARCHITECT PRIOR TO COMMENCEMENT OF WORK.</p> <p>DATE: Feb 19, 2018</p>	<p>SHEET NO.</p> <p>E-06B</p>
	<p>LOCATION: Ground Floor & Fourth Floor, SSS Building, Harlison Road, Baguio City</p>								

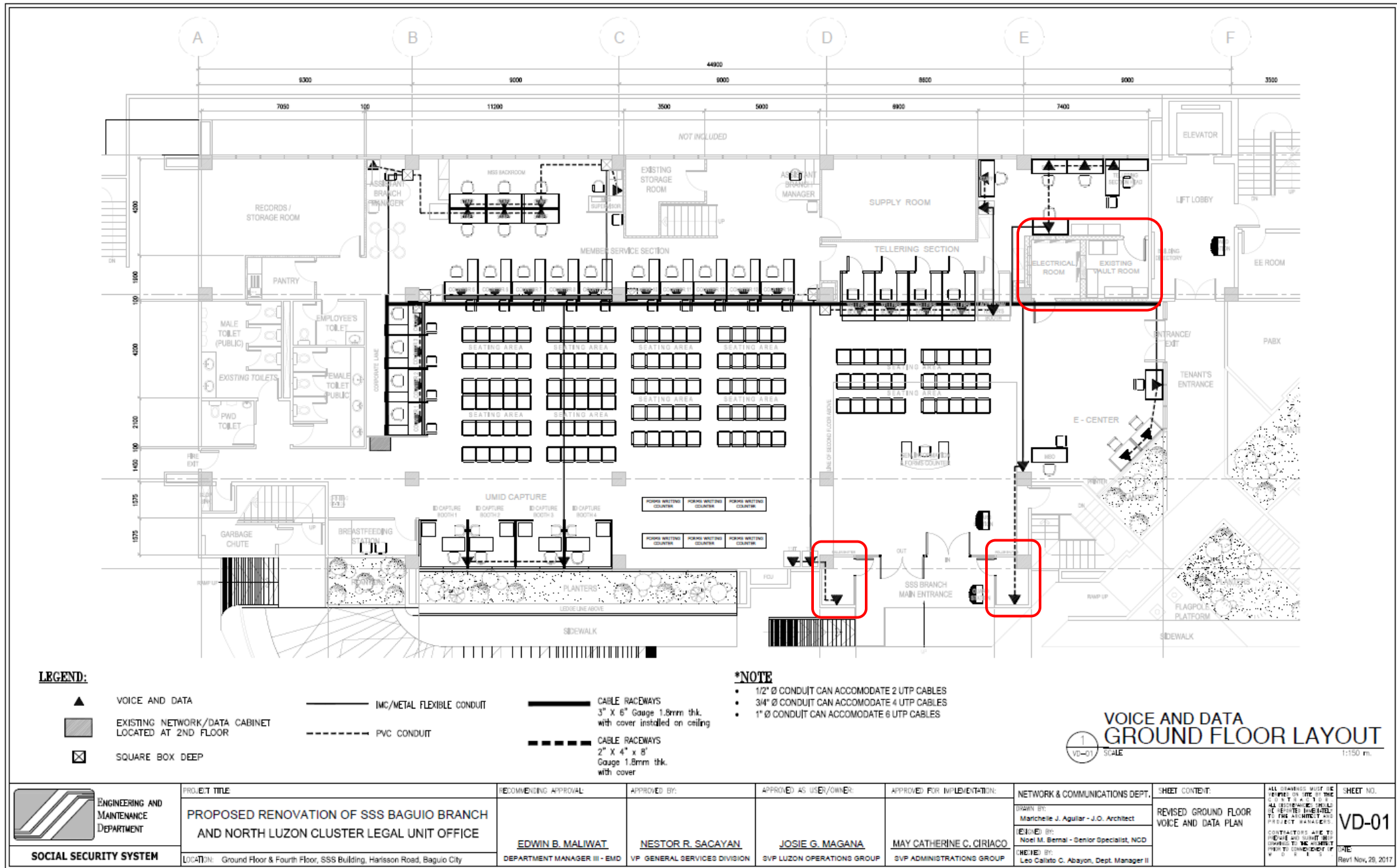

Renovation of 4th Floor (COA, RIMT Records Room, Network Room and Storage Room) and Various Improvements at Ground Floor (Info Kiosk, Electrical Room and Vault Room) at SSS Baguio Building

Handwritten signature

Renovation of 4th Floor at SSS Baguio (COA, RIMT, Records Room Area, Network Room and Storage Room)

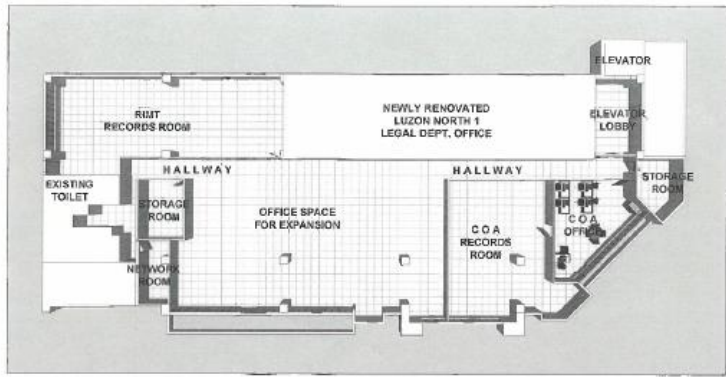

1 INTERIOR PERSPECTIVE
A-00 NOT TO SCALE

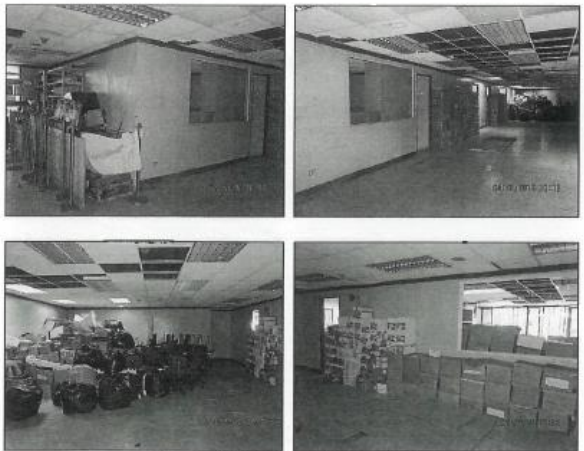
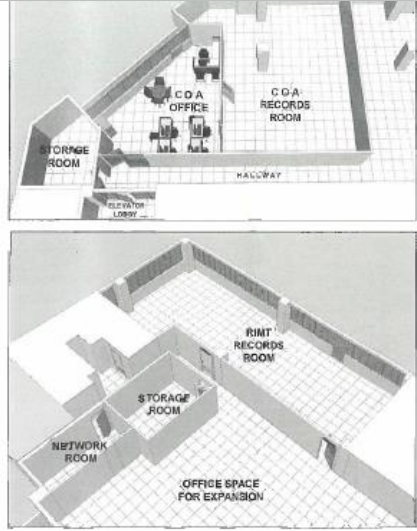

2 SITE PHOTOS
A-00 NOT TO SCALE

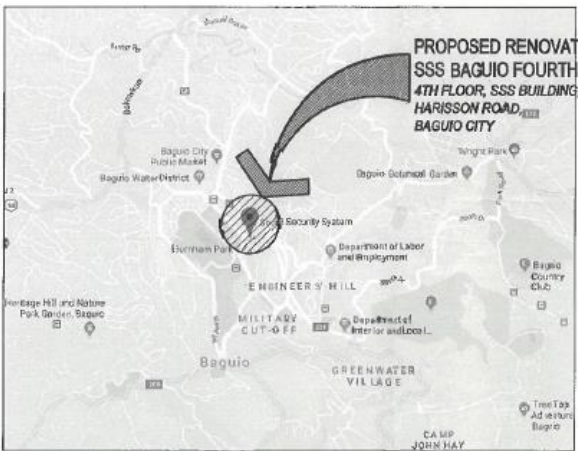

3 LOCATION MAP
A-00 NOT TO SCALE

TABLE OF CONTENTS

ARCHITECTURAL	
A-00	INTERIOR PERSPECTIVE, SITE PHOTOS LOCATION MAP, TABLE OF CONTENTS
A-01	EXISTING FOURTH FLOOR PLAN
A-02	PROPOSED FOURTH FLOOR PLAN
A-03	FURNITURE & DESIGNATION PLAN
A-04	DIMENSION PLAN
A-05	REFLECTED CEILING PLAN
A-06	FLOOR TILE LAYOUT
A-07	LONGITUDINAL SECTIONS 1 & 2
A-08	TRANSVERSE SECTIONS 1&2
A-09	DETAILS OF GLASS DOOR & PARTITION
A-10	SCHEDULE OF DOORS, DETAIL OF SIGNAGE, & GLASS STICKER DETAIL
ELECTRICAL	
E-01	GENERAL NOTES/LEGEND & SYMBOLS
E-02	SINGLE LINE DIAGRAM & LOAD SCHEDULE
E-03	LOAD SCHEDULE CONTINUATION
E-04	FOURTH FLOOR LIGHTING LAYOUT
E-05	FOURTH FLOOR POWER LAYOUT
VOICE AND DATA	
VD-01	FOURTH FLOOR VOICE & DATA LAYOUT

REPUBLIC OF THE PHILIPPINES

SOCIAL SECURITY SYSTEM
EAST AVENUE, QUEZON CITY

OFFICE OF THE ENGINEERING AND FACILITIES MANAGEMENT DEPARTMENT

REVIEWED & CHECKED BY:

[Signature]
MICHAEL A. SAIYO
OFFICER IN CHARGE
CIVIL-ARCHITECTURAL

Project In-Charge: *[Signature]*
ENGR. FERDINAND S. ALMARIO / AR. MARICHELLE J. AGUILAR

REVIEWED & CHECKED BY:

[Signature]
GEORGE N. CARREON
TEAM HEAD
ELECTRO-MECHANICAL I

Project In-Charge: *[Signature]*
ENGR. MA. MELVIN MARRINA A. SAPUGAY

COORDINATED WITH:

[Signature]
LEO CALIXTO C. ABAYON
DEPARTMENT MANAGER III
NETWORK AND COMMUNICATION

Project In-Charge: *[Signature]*
NOEL M. BERNAL / EDUARDO V. DE VERA

[Signature]
HIDELZA B. CASTILLO
VICE PRESIDENT
ICT SUPPORT SERVICES DIVISION

SOCIAL SECURITY SYSTEM ENGINEERING AND FACILITIES MANAGEMENT DEPARTMENT	PROJECT TITLE: PROPOSED FOURTH FLOOR RENOVATION (COA, RIMT RECORDS, NETWORK & STORAGE ROOM)	RECOMMENDING APPROVAL: <i>[Signature]</i> STEPHEN P. YAP ACTING HEAD, ENGINEERING & FACILITIES MANAGEMENT DEPT.	APPROVED AS USER/OWNER: <i>[Signature]</i> EDWIN B. MALIWAT ACTING HEAD - SSS GENERAL SERVICES DIVISION	APPROVED FOR IMPLEMENTATION: <i>[Signature]</i> ANTONIO S. ARGABIOSO ACTING HEAD, LUZON OPERAT. DIV. GROUP	APPROVED FOR IMPLEMENTATION: <i>[Signature]</i> JOHNSY L. MANGRIDAYAO VP, ACTING HEAD, ADM/HR/REG. DIV. GROUP	ENGINEERING TEAM: DESIGNED & DRAWN BY: Marichelle J. Aguilera - Sr. Architect, CAT REVIEWED & CHECKED BY: Michael A. Saiyo - OIC, SSS Archt. Team	SHEET CONTENT: PERSPECTIVE SITE PHOTOS TABLE OF CONTENTS	ALL DRAWINGS MUST BE VERIFIED ON SITE BY THE CONTRACTOR. ALL DISCREPANCIES SHOULD BE REPORTED IMMEDIATELY TO THE ARCHITECT AND PROJECT MANAGERS. CONTRACTORS ARE TO PREPARE AND SUBMIT SHOP DRAWINGS TO THE ARCHITECT PRIOR TO COMMENCEMENT OF WORK.	SHEET NO.: A-00 DATE: Oct. 10, 2018
	LOCATION: Fourth floor, SSS Building, Harrison Road, Baguio City								

[Handwritten Signature]

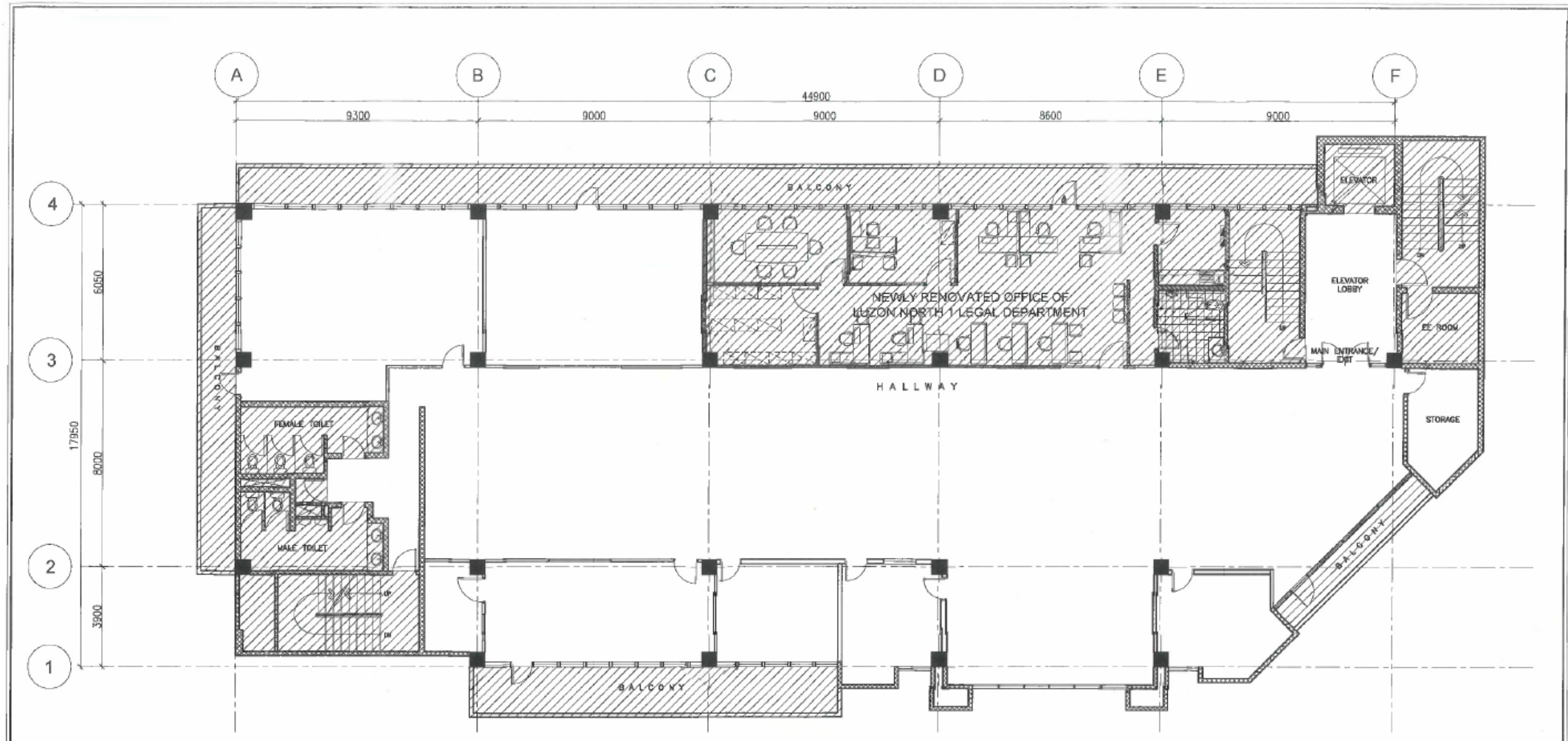

EXISTING
FOURTH FLOOR PLAN
1
A-01 SCALE 1:150

<p>SOCIAL SECURITY SYSTEM ENGINEERING AND FACILITIES MANAGEMENT DEPARTMENT</p>	<p>PROJECT TITLE: PROPOSED FOURTH FLOOR RENOVATION (COA, RIMT RECORDS, NETWORK & STORAGE ROOM)</p>	<p>RECOMMENDING APPROVAL: <i>[Signature]</i> STEPHEN P. YAP ACTING HEAD ENGINEERING & FACILITIES MANAGEMENT DEPT.</p>	<p>APPROVED AS USER/OWNER: <i>[Signature]</i> ANTONIO S. ARGABIOSO ACTING HEAD, LIZON OPERATIONS GROUP</p>	<p>APPROVED FOR IMPLEMENTATION: <i>[Signature]</i> JOHNSY L. MANGUNDAYAO VP, ACTING HEAD, ADMINISTRATION GROUP</p>	<p>ENGINEERING TEAM DESIGNED & DRAWN BY: <i>[Signature]</i> Merchele J. Aguilar - Sr. Architect, CAIT REVIEWED & CHECKED BY: <i>[Signature]</i> Michael A. Saiyo - OIC, CAIT Arch/IT Team</p>	<p>SHEET CONTENT: EXISTING FOURTH FLOOR PLAN</p>	<p>ALL DRAWINGS MUST BE MARKED ON SIDE BY THE CONTRACTOR. ALL DIMENSIONS SHOULD BE INDICATED EXPLICITLY TO THE ARCHITECT AND PROJECT MANAGERS. CONTRACTORS ARE TO PREPARE AND SUBMIT SHOP DRAWINGS TO THE ARCHITECT PRIOR TO COMMENCEMENT OF WORKS.</p>	<p>SHEET NO. A-01 DATE: SEPT. 28, 2018</p>
	<p>LOCATION: Fourth Floor, SSS Building, Harrison Road, Baguio City</p>							

Renovation of 4th Floor (COA, RIMT Records Room, Network Room and Storage Room) and Various Improvements at Ground Floor (Info Kiosk, Electrical Room and Vault Room) at SSS Baguio Building

[Handwritten signature]

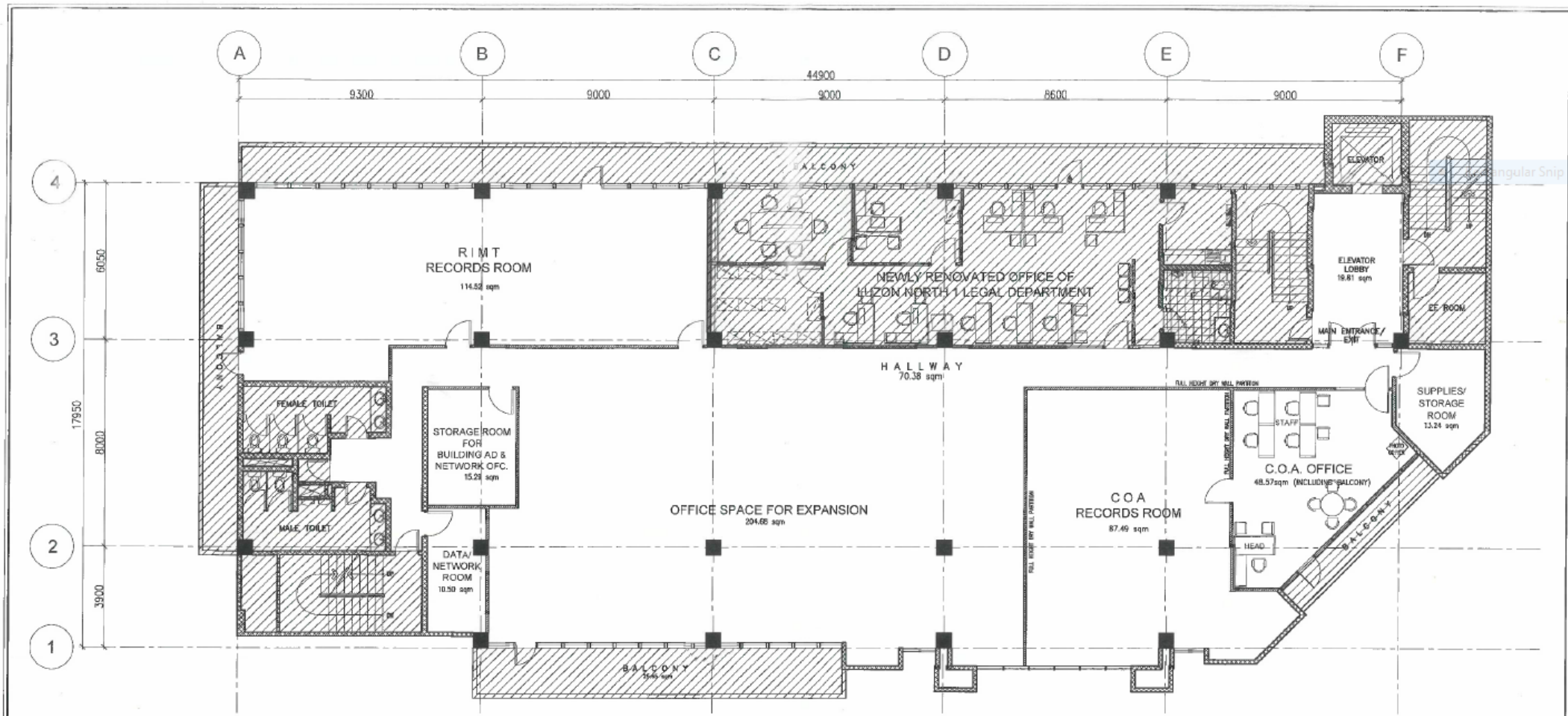

PROPOSED
FOURTH FLOOR PLAN
 1
 A-02 SCALE 1:150 m

NOT INCLUDED

 SOCIAL SECURITY SYSTEM <small>ENGINEERING AND FACILITIES MANAGEMENT DEPARTMENT</small>	<small>PROJECT TITLE:</small>	<small>RECOMMENDING APPROVAL:</small>	<small>APPROVED AS USER/OWNER:</small>	<small>APPROVED FOR IMPLEMENTATION:</small>	<small>ENGINEERING TEAM</small>	<small>SHEET CONTENT:</small>	<small>SHEET NO.</small>
	PROPOSED FOURTH FLOOR RENOVATION (COA, RIMT RECORDS, NETWORK & STORAGE ROOM) <small>LOCATION: Fourth Floor, SSS Building, Harrison Road, Baguio City</small>	 STEPHEN P. YAP <small>ACTING HEAD ENGINEERING & FACILITIES MANAGEMENT DEPT.</small>	 EDWIN B. MALIWAT <small>ACTING HEAD - GSD GENERAL SERVICES DIVISION</small>	 ANTONIO S. ARGABIOSO <small>ACTING HEAD ILLON OPERATIONS GROUP</small>	 JOHNSY L. MANGUNDAYAO <small>VP, ACTING HEAD, ADMINISTRATION GROUP</small>	<small>DESIGNED & DRAWN BY:</small> <small>Marchello J. Argabioso, Architect, CAT</small> <small>REVIEWED & CHECKED BY:</small> <small>Michael A. Sayo - OIC, CAI Archt Team</small>	PROPOSED FOURTH FLOOR PLAN

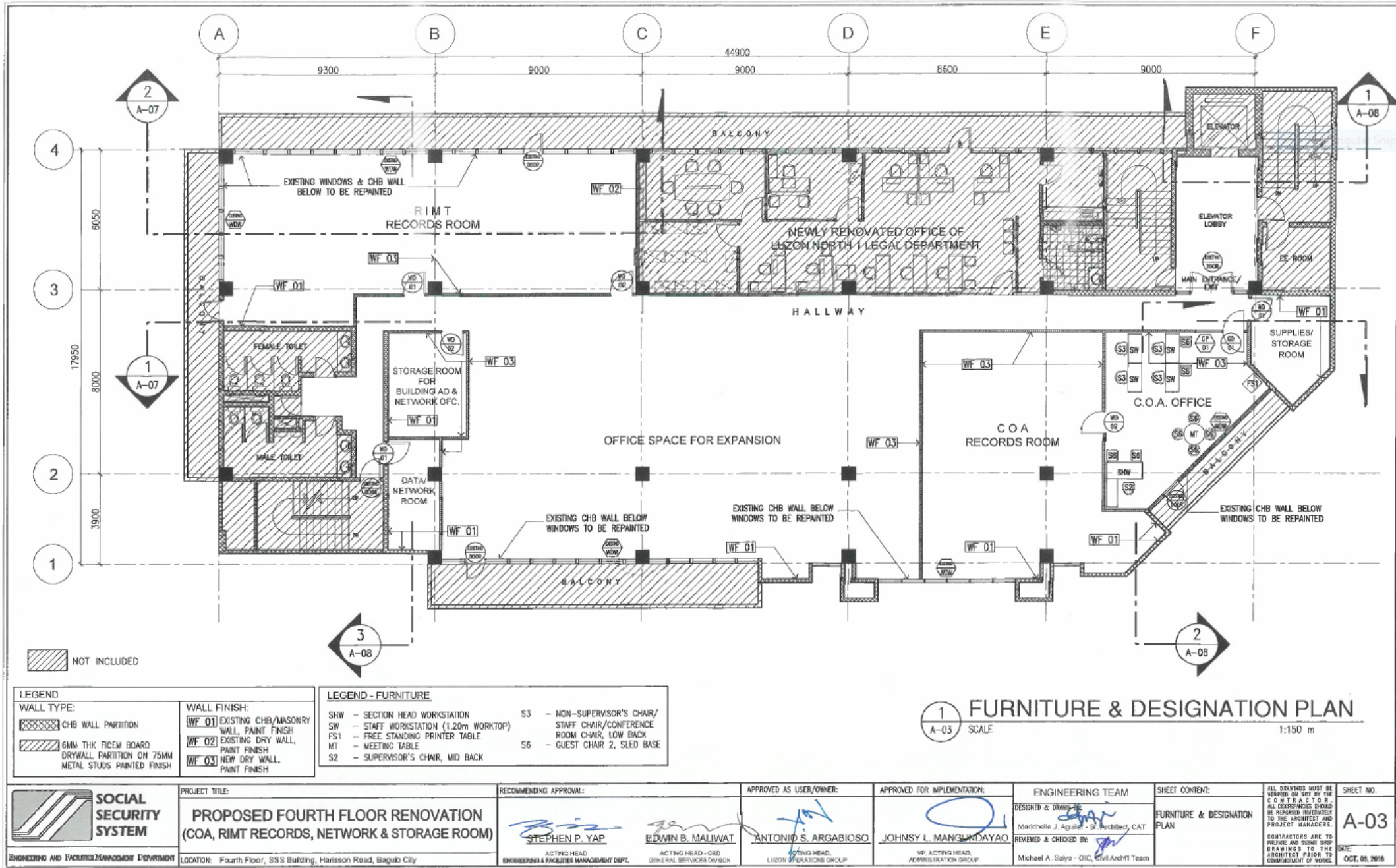

Renovation of 4th Floor (COA, RIMT Records Room, Network Room and Storage Room) and Various Improvements at Ground Floor (Info Kiosk, Electrical Room and Vault Room) at SSS Baguio Building

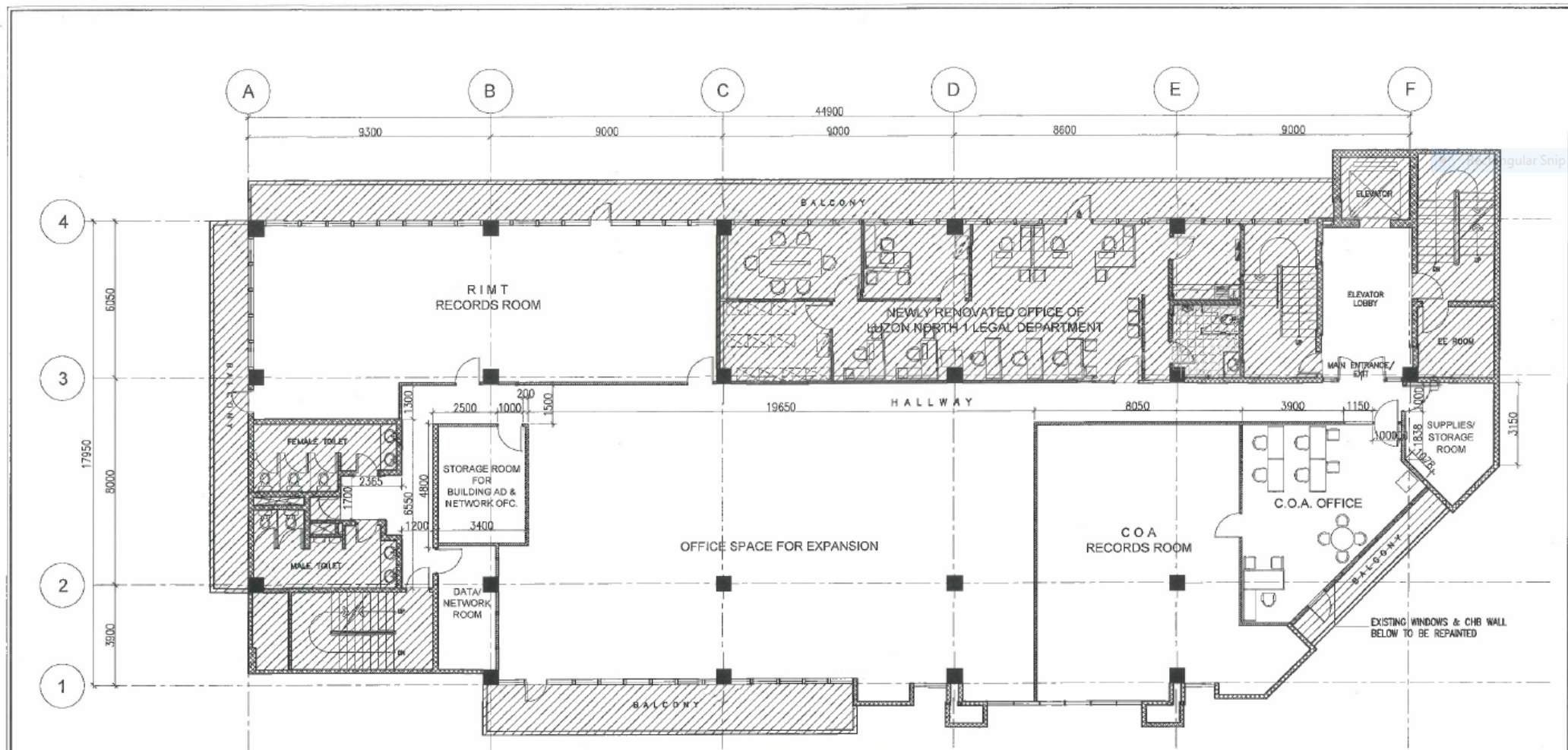

1 DIMENSION PLAN
A-04 SCALE 1:150 m

<p>SOCIAL SECURITY SYSTEM Engineering and Facilities Management Department</p>	PROJECT TITLE: PROPOSED FOURTH FLOOR RENOVATION (COA, RIMT RECORDS, NETWORK & STORAGE ROOM)	RECOMMENDING APPROVAL: STEPHEN P. YAP ACTING HEAD - ENGINEERING & FACILITIES MANAGEMENT DEPT	APPROVED AS USER/OWNER: EDWIN B. MALIWAT ACTING HEAD - GSD GENERAL SERVICES DIVISION	APPROVED FOR IMPLEMENTATION: ANTONIO S. ARGABIOSO ACTING HEAD, LUDOW OPERATIONS GROUP	ENGINEERING TEAM: DESIGNED & DRAWN BY: Marichelle J. Aguilera, Jr. Architect, CAT REVIEWED & CHECKED BY: Michael A. Saiyo - OIC, Civil Architect Team	SHEET CONTENT: DIMENSION PLAN	ALL DRAWINGS MUST BE VERIFIED ON SITE BY THE CONTRACTOR. ALL DISCREPANCIES SHOULD BE REPORTED IMMEDIATELY TO THE ARCHITECT AND PROJECT MANAGERS. CONTRACTORS ARE TO PREPARE AND SUBMIT SHOP DRAWINGS TO THE ARCHITECT PRIOR TO COMMENCEMENT OF WORKS.	SHEET NO. A-04 DATE: OCT. 08, 2016
	LOCATION: Fourth Floor, SSS Building, Harrison Road, Baguio City							

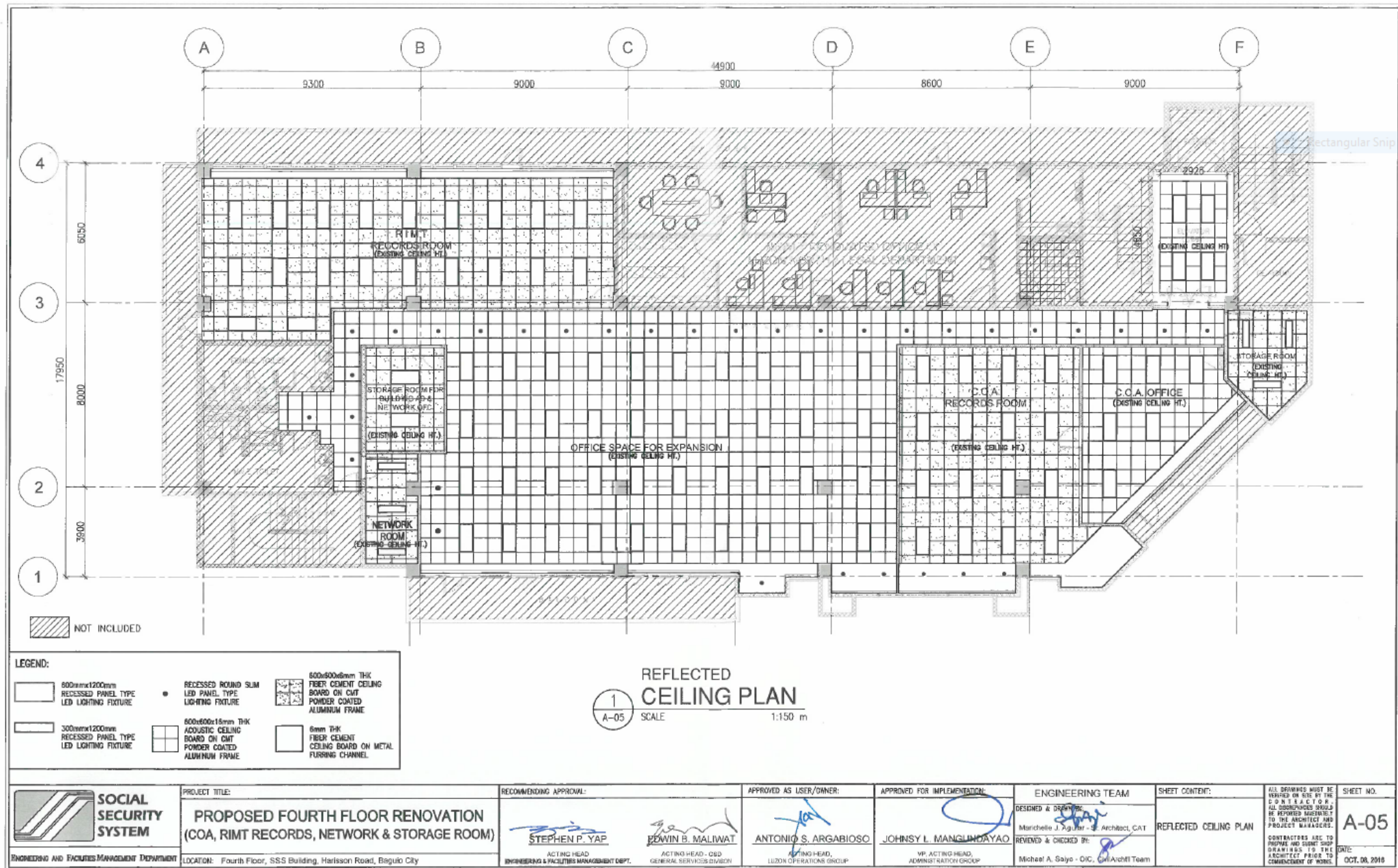

Renovation of 4th Floor (COA, RIMT Records Room, Network Room and Storage Room) and Various Improvements at Ground Floor (Info Kiosk, Electrical Room and Vault Room) at SSS Baguio Building

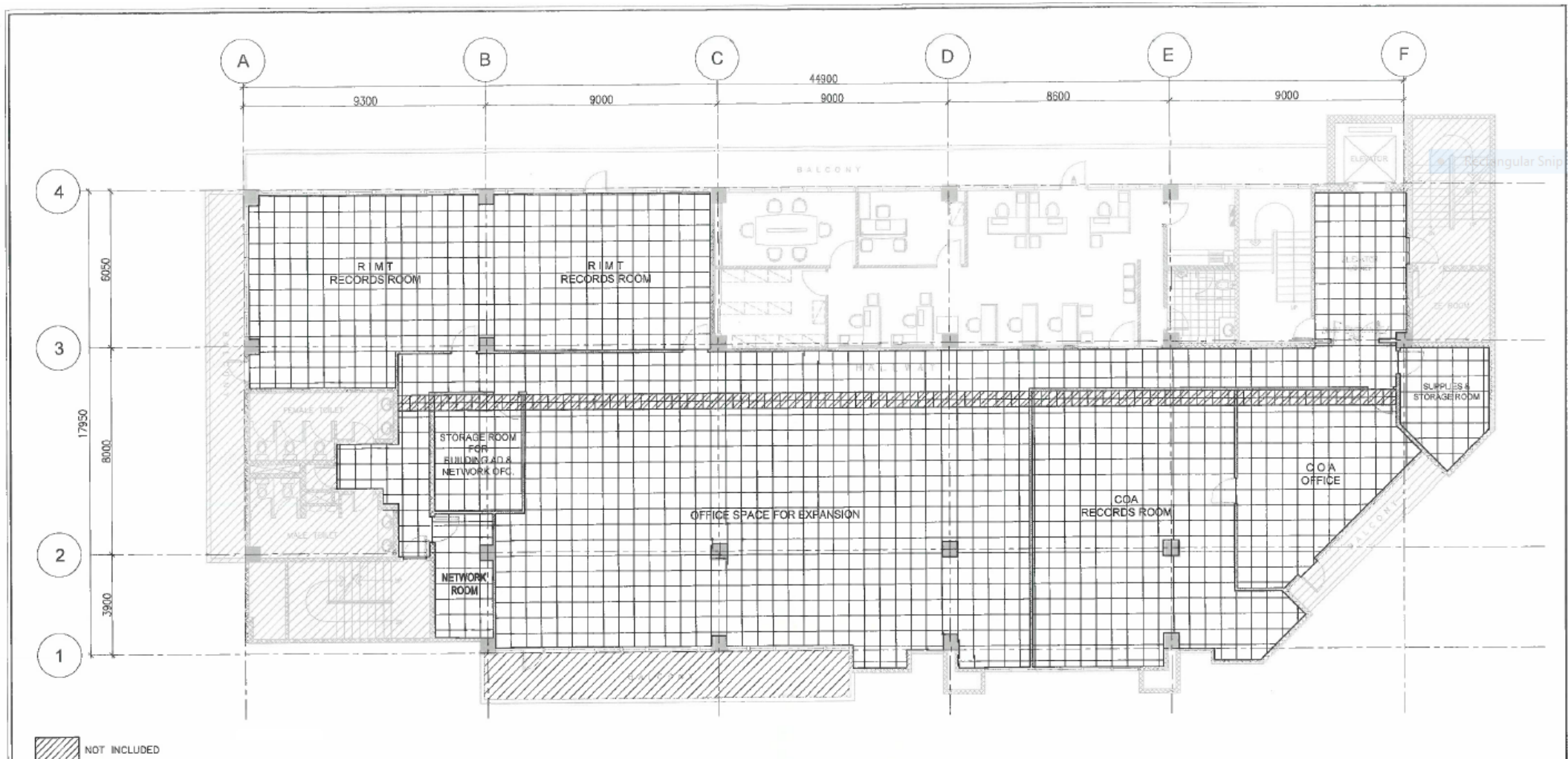

1 FLOOR TILE LAYOUT
 A-06 SCALE 1:150 m

LEGEND:

600mm x 600mm VINYL FLOOR TILES
 300mm x 300mm VINYL FLOOR TILES (FLOOR RACEWAY)
 NOT INCLUDED

SOCIAL SECURITY SYSTEM ENGINEERING AND FACILITIES MANAGEMENT DEPARTMENT	PROJECT TITLE: PROPOSED 4TH FLOOR RENOVATION (COA, RIMT RECORDS, NETWORK AND STORAGE ROOM)	RECOMMENDING APPROVAL: STEPHEN P. YAP ACTING HEAD ENGINEERING & FACILITIES MANAGEMENT DEPT.	APPROVED AS USER/OWNER: EDWIN B. MALAWAT ACTING HEAD - GRD GENERAL SERVICES DIVISION	APPROVED FOR IMPLEMENTATION: ANTONIO S. ARGABIOSO ACTING HEAD, LUZON OPERATIONS GROUP	APPROVED FOR IMPLEMENTATION: JOHNSY L. MANGUNDAYAO VP, ACTING HEAD, ADMINISTRATION GROUP	ENGINEERING TEAM DESIGNED & DRAWN BY: Marichela S. Salinas, Sr. Architect, CAT REVIEWED & CHECKED BY: Michael A. Salayo - OIC, Civil Archt'l Team	SHEET CONTENT: FLOOR TILE LAYOUT	ALL DRAWINGS MUST BE REVIEWED ON-SITE BY THE SUBTRACTOR. ALL DISCREPANCIES SHOULD BE REPORTED IMMEDIATELY TO THE ARCHITECT AND PROJECT MANAGERS. CONTRACTORS ARE TO PREPARE AND SUBMIT SHOP DRAWINGS TO THE ARCHITECT PRIOR TO COMMENCEMENT OF WORK.	SHEET NO. A-06 DATE: OCT. 08, 2018
	LOCATION: Fourth Floor, SSS Building, Harrison Road, Baguio City								

Renovation of 4th Floor (COA, RIMT Records Room, Network Room and Storage Room) and Various Improvements at Ground Floor (Info Kiosk, Electrical Room and Vault Room) at SSS Baguio Building

Handwritten signature

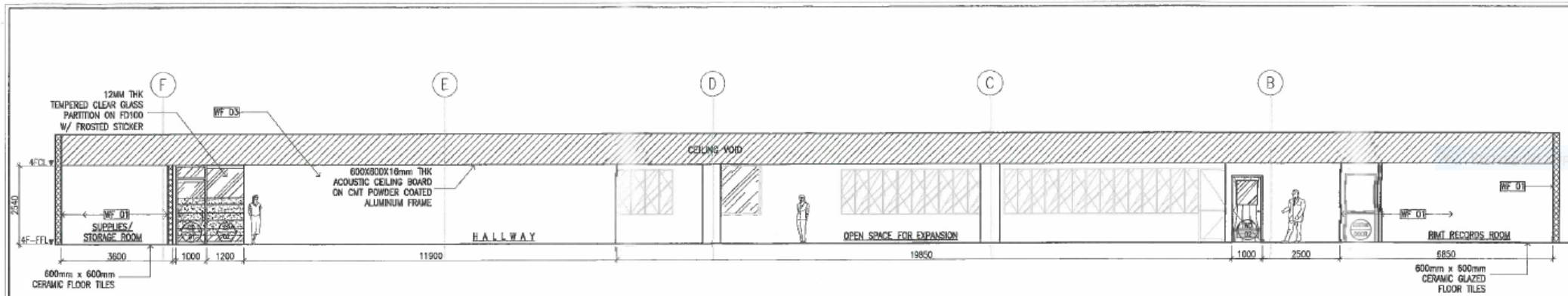

1 LONGITUDINAL SECTION 01
A-07 SCALE 1:125 m

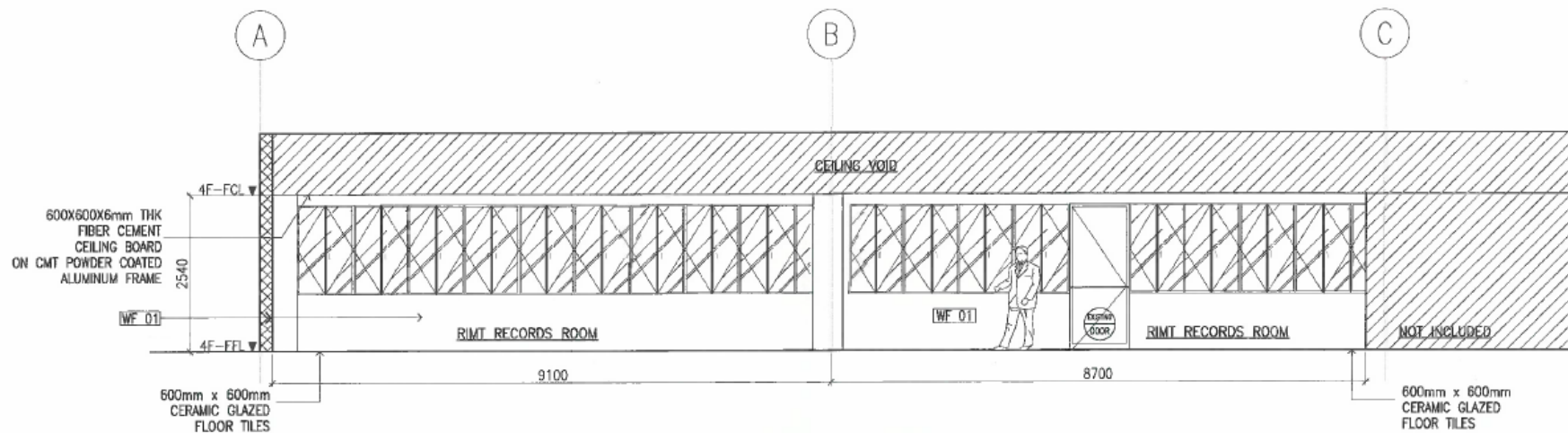

2 LONGITUDINAL SECTION 02A
A-07 SCALE 1:75 m

LEGEND	
WALL TYPE:	WALL FINISH:
CHB WALL PARTITION	WF 01 EXISTING CHB/MASONRY WALL, PAINT FINISH
6MM THK FICEM BOARD DRYWALL PARTITION ON 75MM METAL STUDS PAINTED FINISH	WF 02 EXISTING DRY WALL, PAINT FINISH
	WF 03 NEW DRY WALL, PAINT FINISH

SOCIAL SECURITY SYSTEM ENGINEERING AND FACILITIES MANAGEMENT DEPARTMENT	PROJECT TITLE: PROPOSED FOURTH FLOOR RENOVATION (COA, RIMT RECORDS, NETWORK & STORAGE ROOM)	RECOMMENDING APPROVAL: STEPHEN P. YAP ACTING HEAD, ENGINEERING & FACILITIES MANAGEMENT DEPT.	APPROVED AS USER/OWNER: EDWIN B. MULIWAT ACTING HEAD - OSD, GENERAL SERVICES OFFICE	APPROVED FOR IMPLEMENTATION: ANTONIO S. ARGABIOSO ACTING HEAD, LUXURY OPERATIONS GROUP	APPROVED FOR IMPLEMENTATION: JOHNSY L. MANGUNDAYAO VP, ACTING HEAD, ADMINISTRATION GROUP	ENGINEERING TEAM DESIGNED & DRAWN BY: Marichelle J. Aguilera - Sr. Architect, CAT REVIEWED & CHECKED BY: Michael A. Salya - OIC, Civil Archt Team	SHEET CONTENT: LONGITUDINAL SECTIONS	SHEET NO.: A-07 DATE: OCT. 10, 2016
	LOCATION: Fourth Floor, SSS Building, Harisson Road, Baguio City	REMARKS: ALL DRAWINGS MUST BE WORKED ON SITE BY THE CONTRACTOR. ALL OCCUPANCIES SHOULD BE REPORTED IMMEDIATELY TO THE ARCHITECT AND PROJECT MANAGERS. CONTRACTORS ARE TO PREPARE AND SUBMIT SHOP DRAWINGS TO THE ARCHITECT PRIOR TO COMMENCEMENT OF WORKS.						

Handwritten signature

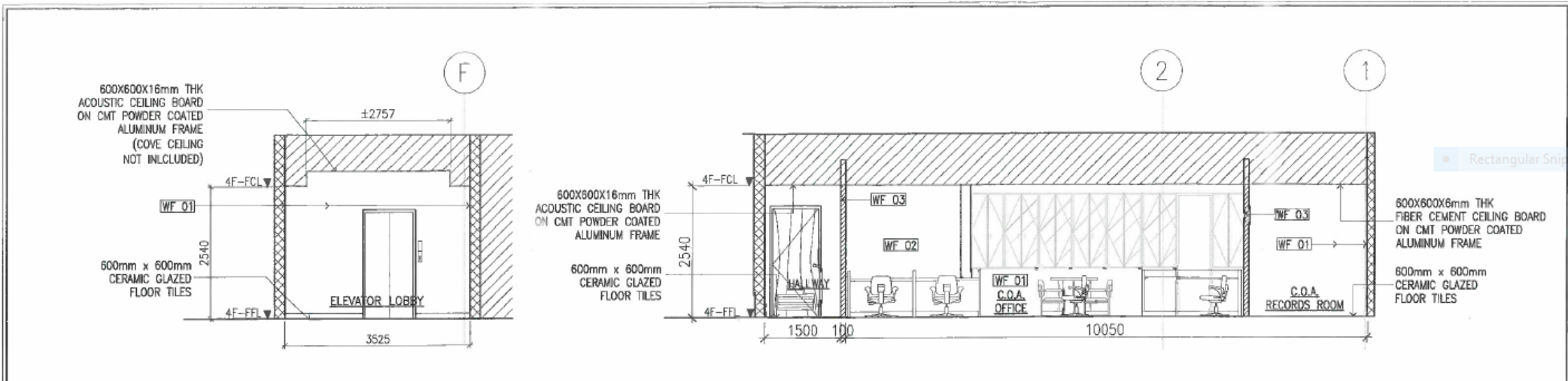

1 LONGITUDINAL SECTION 02B
A-08 SCALE 1:75 m

2 TRANSVERSE SECTION 01
A-08 SCALE 1:75 m

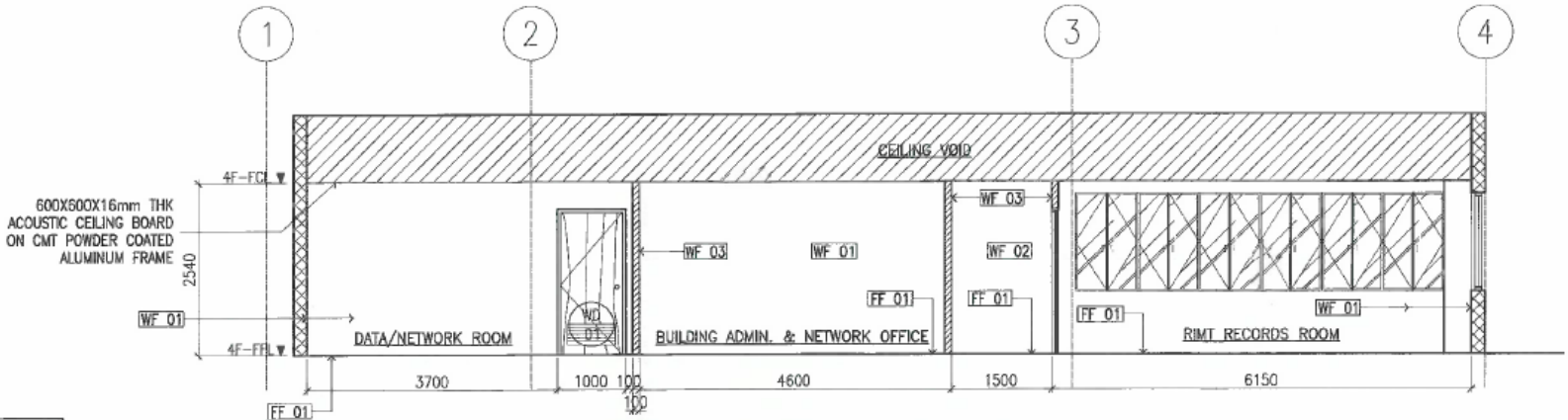

3 TRANSVERSE SECTION 02
A-08 SCALE 1:75 m

LEGEND	
WALL TYPE:	WALL FINISH:
CHB WALL PARTITION	WF 01 EXISTING CHB/MASONRY WALL, PAINT FINISH
6MM THK FIBEC BOARD DRYWALL PARTITION ON 75MM METAL STUDS PAINTED FINISH	WF 02 EXISTING DRY WALL, PAINT FINISH
	WF 03 NEW DRY WALL, PAINT FINISH

SOCIAL SECURITY SYSTEM ENGINEERING AND FACILITIES MANAGEMENT DEPARTMENT	PROJECT TITLE: PROPOSED FOURTH FLOOR RENOVATION (COA, RIMT RECORDS, NETWORK & STORAGE ROOM)	RECOMMENDING APPROVAL: STEPHEN P. YAP ACTING HEAD - GSD ENGINEERING & FACILITIES MANAGEMENT DEPT.	APPROVED AS USER/OWNER: EDWIN B. MALIWAT ACTING HEAD - GSD GENERAL SERVICES DIVISION	APPROVED FOR IMPLEMENTATION: ANTONIO S. ARGABIOSIO ACTING HEAD - LUCO LUCO OPERATIONS GROUP	ENGINEERING TEAM: DESIGNED & DRAWN BY: Marichona J. Alarcon, Architect, CAT REVIEWED & CHECKED BY: Michael A. Saliyo - OIC, Civil/Struct Team	SHEET CONTENT: LONGITUDINAL & TRANSVERSE SECTIONS	SHEET NO.: A-08 DATE: OCT. 11, 2018
	LOCATION: Fourth Floor, SSS Building, Harisson Road, Baguio City	ALL DRAWINGS MUST BE VERIFIED ON SITE BY THE E.O. & I.R.A.C.E.T.D.R. ALL DISCREPANCIES SHOULD BE REPORTED IMMEDIATELY TO THE ARCHITECT AND PROJECT MANAGERS. CONTRACTORS ARE TO PROTECT AND SUBMIT SHOP DRAWINGS TO THE ARCHITECT PRIOR TO COMMENCEMENT OF WORKS.					

Renovation of 4th Floor (COA, RIMT Records Room, Network Room and Storage Room) and Various Improvements at Ground Floor (Info Kiosk, Electrical Room and Vault Room) at SSS Baguio Building

Rectangular Snip

<p>GD 01</p> <p>DESIGNATION: GLASS DOOR 01</p> <p>DESCRIPTION: SINGLE LEAF DOOR w/ TRANSOM 12mm thk TEMPERED CLEAR GLASS w/ STAINLESS STEEL DOOR HANDLE COMPLETE w/ PATCH FITTINGS, HARDWARES & ACCESSORIES w/ VINYL FROSTED STICKER AS SHOWN</p> <p>LOCATION: COMMISSION ON HUMAN RIGHTS OFFICE</p> <p>1 SET/S REQ'D</p>	<p>GP 01</p> <p>DESIGNATION: GLASS PARTITION 01</p> <p>DESCRIPTION: 12mm thk TEMPERED, CLEAR GLASS ON FD 100 TOP & BOTTOM, POWDER COATED FINISH w/ VINYL FROSTED STICKER AS SHOWN</p> <p>1 SET/S REQ'D</p>	<p>WD 01</p> <p>DESIGNATION: WOOD DOOR 01</p> <p>DESCRIPTION: FLUSH HOLLOW CORE WOOD DOOR w/ BOTTOM LOUVER, CYLINDRICAL LOCKSET, & DOOR CLOSER, COMPLETE w/ HARDWARES & ACCESSORIES</p> <p>LOCATION: SUPPLIES ROOM, RIMT RECORDS ROOM, DATA/NETWORK ROOM</p> <p>3 SETS REQ'D</p>	<p>WD 02</p> <p>DESIGNATION: WOOD DOOR 02</p> <p>DESCRIPTION: FLUSH HOLLOW CORE WOOD DOOR w/ BOTTOM LOUVER & VISION GLASS, CYLINDRICAL LOCKSET & DOOR CLOSER, COMPLETE w/ HARDWARES & ACCESSORIES</p> <p>LOCATION: COA RECORDS ROOM, RIMT RECORDS ROOM & STORAGE RM FOR BLDG. ADMIN.</p> <p>3 SETS REQ'D</p>

SCHEDULE OF DOORS & GLASS PARTITIONS

1
A-09 SCALE 1:50 M

<p>SOCIAL SECURITY SYSTEM</p> <p>ENGINEERING AND FACILITIES MANAGEMENT DEPARTMENT</p>	<p>PROJECT TITLE:</p> <p>PROPOSED FOURTH FLOOR RENOVATION (COA, RIMT RECORDS, NETWORK & STORAGE ROOM)</p>	<p>RECOMMENDING APPROVAL:</p> <p><i>[Signature]</i> STEPHEN P. YAP ACTING HEAD, ENGINEERING & FACILITIES MANAGEMENT DEPT.</p>	<p>APPROVED AS USER/OWNER:</p> <p><i>[Signature]</i> ERWIN B. MALIWAT ACTING HEAD - CSD, GENERAL SERVICES DIVISION</p>	<p>APPROVED FOR IMPLEMENTATION:</p> <p><i>[Signature]</i> ANTONIO S. ARGABIOSO ACTING HEAD, LOGISTICS OPERATIONS GROUP</p>	<p>ENGINEERING TEAM:</p> <p>DESIGNED & DRAWN BY: <i>[Signature]</i> Marichelle J. Aguilera, Sr. Architect, CAT</p> <p>REVIEWED & CHECKED BY: <i>[Signature]</i> Michael A. Salayo - DIC, Civil Architect Team</p>	<p>SHEET CONTENT:</p> <p>SCHEDULE OF DOORS & GLASS DOOR & PARTITION</p>	<p>ALL DRAWINGS MUST BE VERIFIED ON SITE BY THE CONTRACTOR. ALL REQUIREMENTS SHOULD BE REPORTED IMMEDIATELY TO THE ARCHITECT AND PROJECT MANAGERS.</p> <p>CONTRACTORS ARE TO FURNISH AND SUBMIT SHOP DRAWINGS TO THE ARCHITECT PRIOR TO COMMENCEMENT OF WORKS.</p>	<p>SHEET NO.</p> <p>A-09</p> <p>DATE: OCT. 12, 2018</p>
	<p>LOCATION: Fourth Floor, SSS Building, Herlison Road, Baguio City</p>							

[Handwritten Signature]

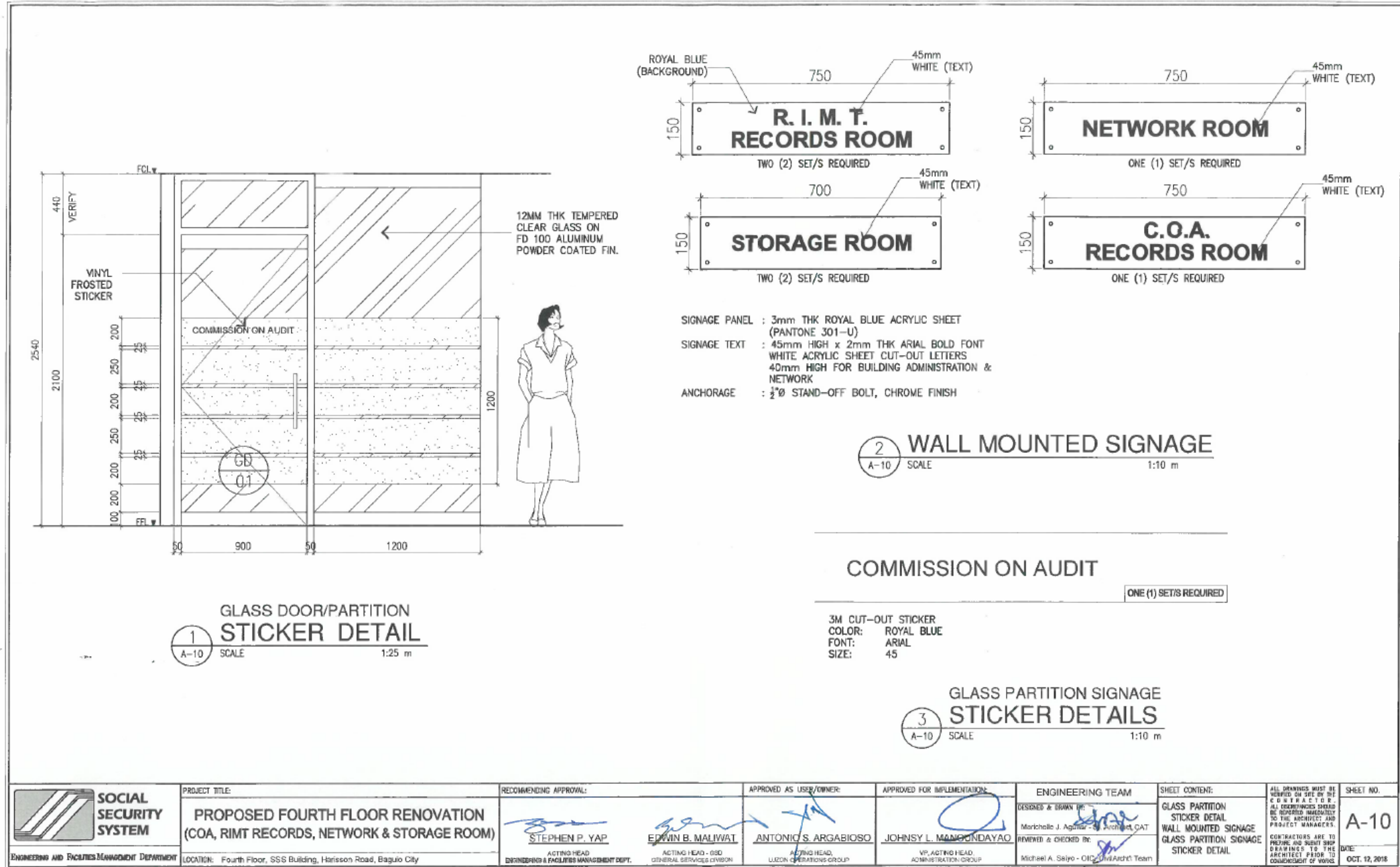

Renovation of 4th Floor (COA, RIMT Records Room, Network Room and Storage Room) and Various Improvements at Ground Floor (Info Kiosk, Electrical Room and Vault Room) at SSS Baguio Building

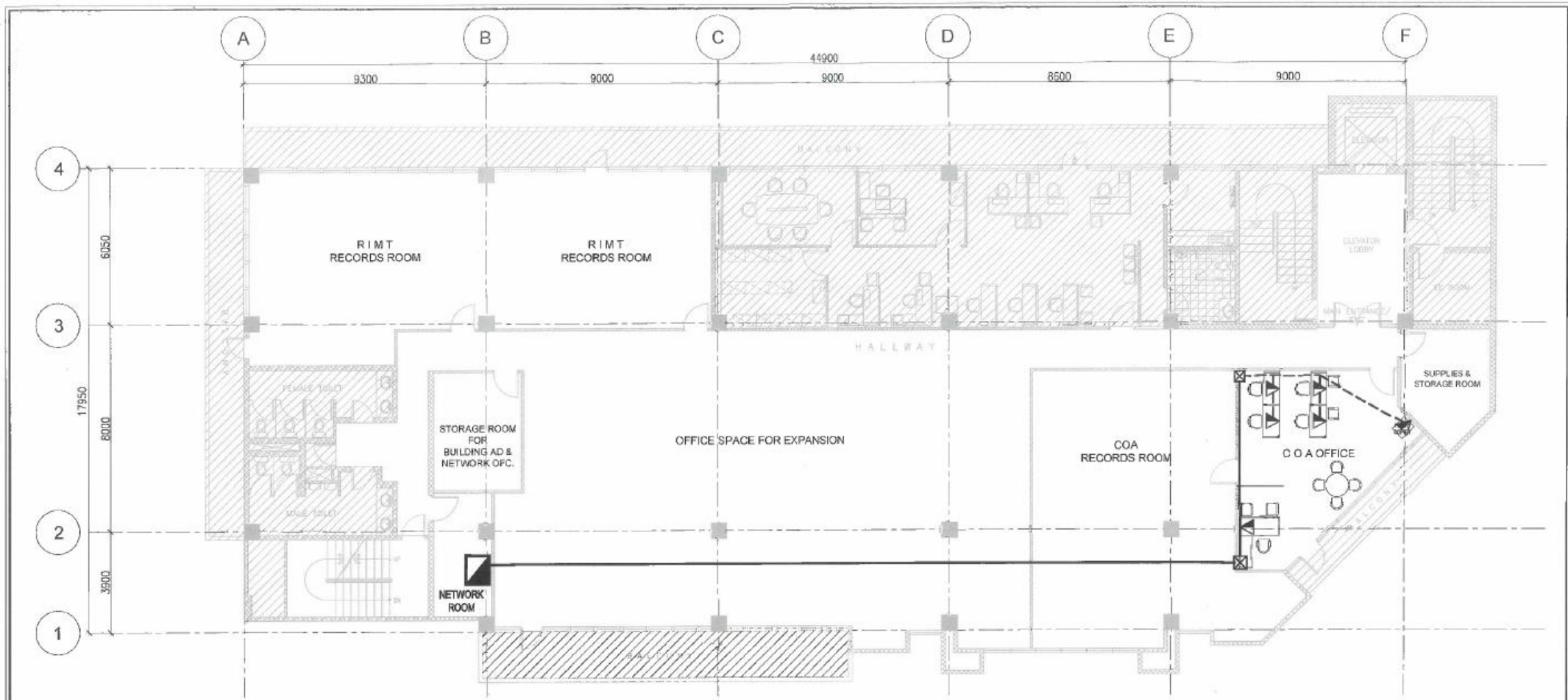

LEGEND:

	IMC CONDUIT INSTALLED AT 4TH FLOOR CEILING		PULL BOX/SQUARE BOX
	CONDUIT		DATA & VOICE
	IDF		

**FOURTH FLOOR
VOICE AND DATA LAYOUT**
 1
 Aux01 SCALE 1:150 M

 ENGINEERING AND FACILITIES MANAGEMENT DEPARTMENT SOCIAL SECURITY SYSTEM	PROJECT TITLE: PROPOSED FOURTH FLOOR RENOVATION (COA, RIMT RECORDS, NETWORK & STORAGE ROOM)	RECOMMENDING APPROVAL: LEO CALIXTO C. ARAYON <small>DEPARTMENT MANAGER III - NCD</small>	APPROVED AS USER/OWNER: FIDELZA B. CASTILLO <small>VP - ICT SUPPORT SERVICES DIVISION</small>	APPROVED FOR IMPLEMENTATION: ANTONIO S. ARGABIOSO <small>ACTING HEAD, LIAISON OPERATIONS GROUP</small>	APPROVED FOR IMPLEMENTATION: JOHNSY L. MANGUNARYAO <small>VP, ACTING HEAD, ADMINISTRATION GROUP</small>	NETWORK & COMMUNICATIONS DEPARTMENT <small>DRAWN BY: Manonelle J. Aguirre Jr., Architect, CAT DESIGNED BY: MORIS ANTONIO C. CRISTOBAL, NCD REVIEWED & CHECKED BY: EDUARDO V. DELA TORRE, NCD</small>	SHEET CONTENT: PROPOSED VOICE AND DATA LAYOUT	<small>ALL DRAWINGS MUST BE VERIFIED ON SITE BY THE CONTRACTOR. ALL DISCREPANCIES SHOULD BE REPORTED IMMEDIATELY TO THE ARCHITECT AND PROJECT MANAGERS. CONTRACTORS ARE TO PREPARE AND SUBMIT SHOP DRAWINGS TO THE ARCHITECT PRIOR TO COMMENCEMENT OF WORKS.</small>	SHEET NO. Aux 01 <small>DATE: January 11, 2018</small>
	<small>LOCATION: Fourth floor, SSS Building, Harrison Road, Baguio City</small>	<small>DEPARTMENT MANAGER III - NCD</small>	<small>VP - ICT SUPPORT SERVICES DIVISION</small>	<small>ACTING HEAD, LIAISON OPERATIONS GROUP</small>	<small>VP, ACTING HEAD, ADMINISTRATION GROUP</small>	<small>DRAWN BY: Manonelle J. Aguirre Jr., Architect, CAT DESIGNED BY: MORIS ANTONIO C. CRISTOBAL, NCD REVIEWED & CHECKED BY: EDUARDO V. DELA TORRE, NCD</small>			

Renovation of 4th Floor (COA, RIMT Records Room, Network Room and Storage Room) and Various Improvements at Ground Floor (Info Kiosk, Electrical Room and Vault Room) at SSS Baguio Building



















Handwritten signature

GENERAL NOTES

- ALL ELECTRICAL WORKS HEREIN SHALL BE DONE IN ACCORDANCE WITH THE PROVISIONS OF THE LATEST EDITION OF THE PHILIPPINE ELECTRICAL CODE (PEC), LAWS AND ORDINANCES OF THE LOCAL CODE ENFORCING AUTHORITIES AND REQUIREMENT OF THE LOCAL POWER AND TELEPHONE COMPANY.
- SERVICE POWER SHALL BE 230 VOLTS, SINGLE PHASE, 3 WIRES, 60 HZ.
- SMALLEST BRANCH CIRCUIT WIRE SHALL BE 3.5 MM² THHN FOR POWER AND LIGHTING AND SHALL BE INSULATED FOR 600 VOLTS.
- WHENEVER NECESSARY PROVIDE PULL BOX OF PROPER SIZE AND DIMENSION ALTHOUGH NOT INDICATED IN THE PLAN.
- ALL BRANCH CIRCUIT SHALL BE INSTALLED AS INDICATED IN THE PLAN, INDIVIDUAL BRANCH CIRCUIT HOMERUNS SHALL NOT BE COMBINED IN THE SAME CONDUIT.
- ALL SWITCHES, PANEL BOARDS, LIGHTING FIXTURES AND ALL NON-CURRENT CARRYING METAL PARTS SHALL BE PROPERLY GROUNDED IN ACCORDANCE WITH THE LATEST EDITION OF THE PEC.
- ROUGHING-IN CONDUITS SHALL BE OF APPROVED TYPE AND APPLICATION, RSC EXPOSED, IMC AND PVC FOR LATERAL AND EMBEDDED LAY-OUT.
- THE ELECTRICAL CONTRACTOR IS REQUIRED TO VISIT AND SURVEY THE SITE TO ASCERTAIN THE LOCAL CONDITION THAT MAY AFFECT DURING THE IMPLEMENTATION OF THE PROJECT.
- ALL AREA AFFECTED BY THE CHIPPING/REMOVAL WORKS SHALL BE PATCHED OR RESTORED TO ITS ORIGINAL AESTHETIC CONDITION.
- MOUNTING HEIGHTS SHALL BE AS FOLLOWS:

PANELBOARD	----	1.40 m	ABOVE FINISHED FLOOR
SWITCHES	----	1.40 m	ABOVE FINISHED FLOOR
CONVENIENCE OUTLETS	----	0.30 m	ABOVE FINISHED FLOOR (FOR WALL MOUNTED)
	----		MODULAR RACEWAY (ON MODULAR WORKSTATIONS)
- ALL ELECTRICAL WORKS HEREIN SHALL BE DONE UNDER THE SUPERVISION OF DULY LICENSED ELECTRICAL ENGINEER OR MASTER ELECTRICIAN.

SYMBOLS & LEGEND:

-  DUPLEX CONVENIENCE OUTLET, 3 PRONG, PARALLEL SLOT WITH GROUND, 15A, 2P 230V BY UPS POWER IN FLUSH MOUNTED TYPE WITH OFF-WHITE PLATE COVER
-  DUPLEX CONVENIENCE OUTLET, 3 PRONG, PARALLEL SLOT WITH GROUND, 15A, 2P 230V BY NORMAL POWER IN FLUSH MOUNTED TYPE WITH BEIGE PLATE COVER
-  RECESSED PANEL TYPE LED LIGHTING FIXTURE, COOL DAY LIGHT, 1200X600, 32W, 220V
-  RECESSED PANEL TYPE LED LIGHTING FIXTURE, COOL DAY LIGHT, 1200X300, 24W, 220V
-  RECESSED ROUND SLIM LED PANEL TYPE, COOL DAY LIGHT, LIGHTING FIXTURE, 18W, 220V
-  EXHAUST FAN (REFER TO ME PLAN) WITH C.O W/ MALE PLUG
-  2 WATTS (MINIMUM) LED, 220VAC, DIRECTIONAL EXIT LIGHT WITH C.O.
-  2 WATTS (MINIMUM) LED, 220VAC, FIRE EXIT LIGHT WITH C.O.
-  2 X 1WATT (MINIMUM) LED, 220VAC, EMERGENCY LIGHT WITH C.O.
-  JUNCTION BOX
-  DISTRIBUTION PANEL
-  ECB, NEMA 3R ENCLOSURE
-  ONE GANG SWITCH, SINGLE POLE 15A, 250 V FLUSH TYPE (NATIONAL/PANASONIC BRAND)
-  TWO GANG SWITCH, SINGLE POLE 15A, 250 V FLUSH TYPE (NATIONAL/PANASONIC BRAND)
-  THREE GANG SWITCH, SINGLE POLE 15A, 250 V FLUSH TYPE (NATIONAL/PANASONIC BRAND)
-  THREE-WAY SWITCH, SINGLE POLE 15A, 250 V FLUSH TYPE (NATIONAL/PANASONIC BRAND)
-  CIRCUIT DESIGNATION
-  BRANCH CIRCUIT HOMERUN

 ENGINEERING AND FACILITIES MANAGEMENT DEPARTMENT SOCIAL SECURITY SYSTEM	PROJECT TITLE:	RECOMMENDING APPROVAL:	APPROVED AS USER/OWNER:	APPROVED FOR IMPLEMENTATION:	ENGINEERING TEAM	SHEET CONTENT:	ALL DRAWINGS MUST BE VERIFIED ON SITE BY THE CONTRACTOR. ALL DISCREPANCIES SHOULD BE REPORTED IMMEDIATELY TO THE ARCHITECT AND PROJECT MANAGERS. CONTRACTORS ARE TO PREPARE AND SUBMIT SHOP DRAWINGS TO THE ARCHITECT PRIOR TO COMMENCEMENT OF WORKS.	SHEET NO.
	PROPOSED RENOVATION OF SSS BAGUIO FOURTH FLOOR LOCATION: Fourth Floor, SSS Building, Harisson Road, Baguio City	STEPHEN P. YAP ACTING HEAD, EFMD	ROWIN B. MALIWAT ACTING HEAD, OSD	ANTONIO S. ARGABIOSO ACTING HEAD, UJONH OPERATIONS GROUP	JOHNSY L. MANGUNDAYAO VP, ACTING HEAD, ADMINISTRATION GROUP	DESIGNED & DRAWN BY: MMKA Serapay - F. Arroyo CHECKED BY: George N. Castro, JSSD V, EMT-1	GENERAL NOTES LEGENDS AND SYMBOLS	E-01 DATE: July 03, 2020

Handwritten signature

SINGLE LINE DIAGRAM

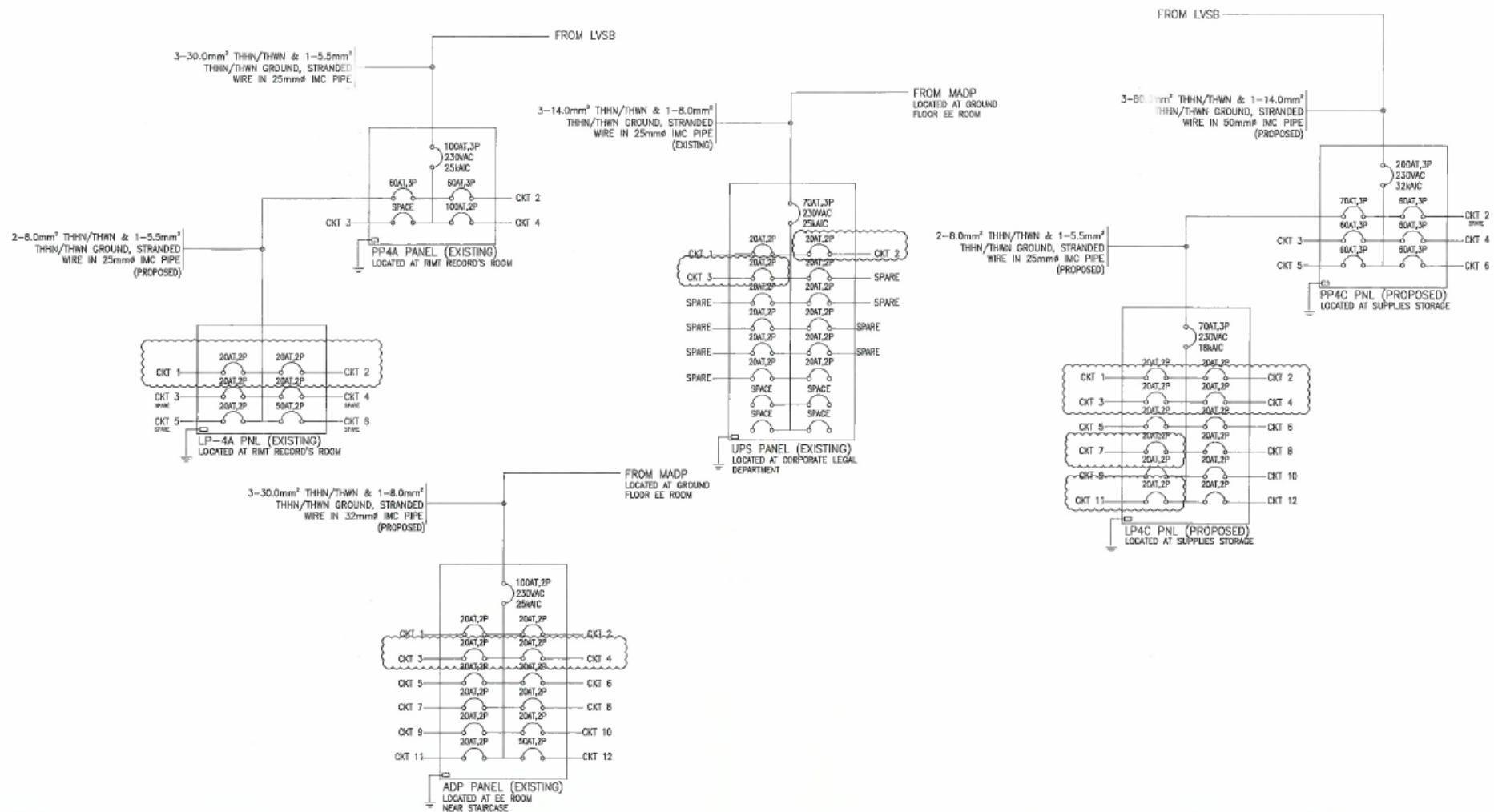

<p>ENGINEERING AND FACILITIES MANAGEMENT DEPARTMENT</p> <p>SOCIAL SECURITY SYSTEM</p>	<p>PROJECT TITLE:</p> <p>PROPOSED RENOVATION OF SSS BAGUIO FOURTH FLOOR</p> <p>LOCATION: Fourth Floor, SSS Building, Harrison Road, Baguio City</p>	<p>RECOMMENDING APPROVAL:</p> <p><i>[Signature]</i> STEPHEN P. YAP ACTING HEAD, EFMD</p>	<p>APPROVED AS USER/OWNER:</p> <p><i>[Signature]</i> EDWIN B. MALIWAT ACTING HEAD, GSD</p>	<p>APPROVED FOR IMPLEMENTATION:</p> <p><i>[Signature]</i> ANTONIO S. ARGABIOSO ACTING HEAD, MOON OPERATIONS GROUP</p>	<p>APPROVED FOR IMPLEMENTATION:</p> <p><i>[Signature]</i> JOHNSYL MANGUNDAYAO VP, ACTING HEAD, ADMINISTRATION GROUP</p>	<p>ENGINEERING TEAM:</p> <p>DESIGNED & DRAWN BY: MRK A. SANCHEZ, Sr. Analyst</p> <p>REVIEWED BY: George N. Carmona - SSO V, EMT-1</p>	<p>SHEET CONTENT:</p> <p>SINGLE LINE DIAGRAM</p>	<p>ALL DRAWINGS MUST BE VERIFIED ON SITE BY THE CONTRACTOR. ALL DISCREPANCIES SHOULD BE REPORTED IMMEDIATELY TO THE ARCHITECT AND PROJECT MANAGERS.</p> <p>CONTRACTORS ARE TO PREPARE AND SUBMIT SITE SURVEY DATA TO THE ARCHITECT PRIOR TO COMMENCEMENT OF WORKS.</p> <p>DATE: July 15, 2020</p>	<p>SHEET NO.</p> <p>E-02</p>
	<p><i>[Handwritten Signature]</i></p>								

Renovation of 4th Floor (COA, RIMT Records Room, Network Room and Storage Room) and Various Improvements at Ground Floor (Info Kiosk, Electrical Room and Vault Room) at SSS Baguio Building

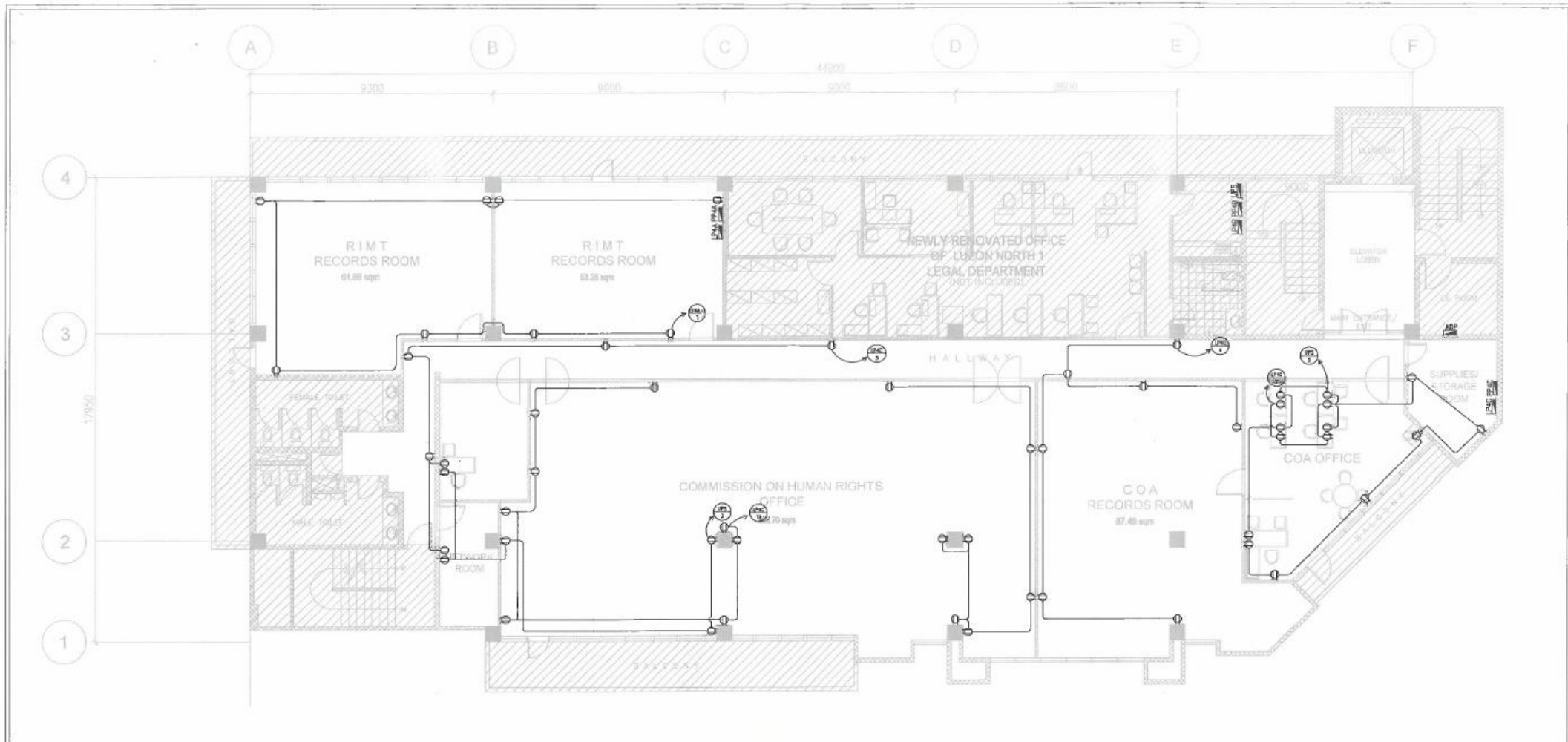

1 PROPOSED POWER LAYOUT
E-03 SCALE 1:150

 ENGINEERING AND FACILITIES MANAGEMENT DEPARTMENT SOCIAL SECURITY SYSTEM	PROJECT TITLE:	RECOMMENDING APPROVAL:	APPROVED AS USER/OWNER:	APPROVED FOR IMPLEMENTATION:	ENGINEERING TEAM	SHEET CONTENT:	ALL DRAWINGS MUST BE VERIFIED BY ONE OF THE CONTRACTORS. ALL DISCREPANCIES SHOULD BE REPORTED IMMEDIATELY TO THE ARCHITECT AND PROJECT MANAGERS.	SHEET NO.:
	PROPOSED RENOVATION OF SSS BAGUIO FOURTH FLOOR LOCATION: Fourth Floor, SSS Building, Harrison Road, Baguio City	STEPHEN P. YAP ACTING HEAD, EFMD	EDWIN B. MALIWAT ACTING HEAD, GSD	ANTONIO S. ARGABIOSO ACTING HEAD, LEGAL OPERATIONS GROUP	JOHNSYL L. MANGUNDAYAO VP, ACTING HEAD, ADMINISTRATION GROUP	DESIGNED & DRAWN BY: MNK A. Gasparyan, SP Analyst REVIEWED BY: George N. Carrobin - SSO V, EMT-1	PROPOSED POWER LAYOUT	CONTRACTORS ARE TO PREPARE AND SUBMIT SHOP DRAWINGS TO THE ARCHITECT PRIOR TO COMMENCEMENT OF WORKS. DATE: July 18, 2020

Renovation of 4th Floor (COA, RIMT Records Room, Network Room and Storage Room) and Various Improvements at Ground Floor (Info Kiosk, Electrical Room and Vault Room) at SSS Baguio Building

Handwritten signature

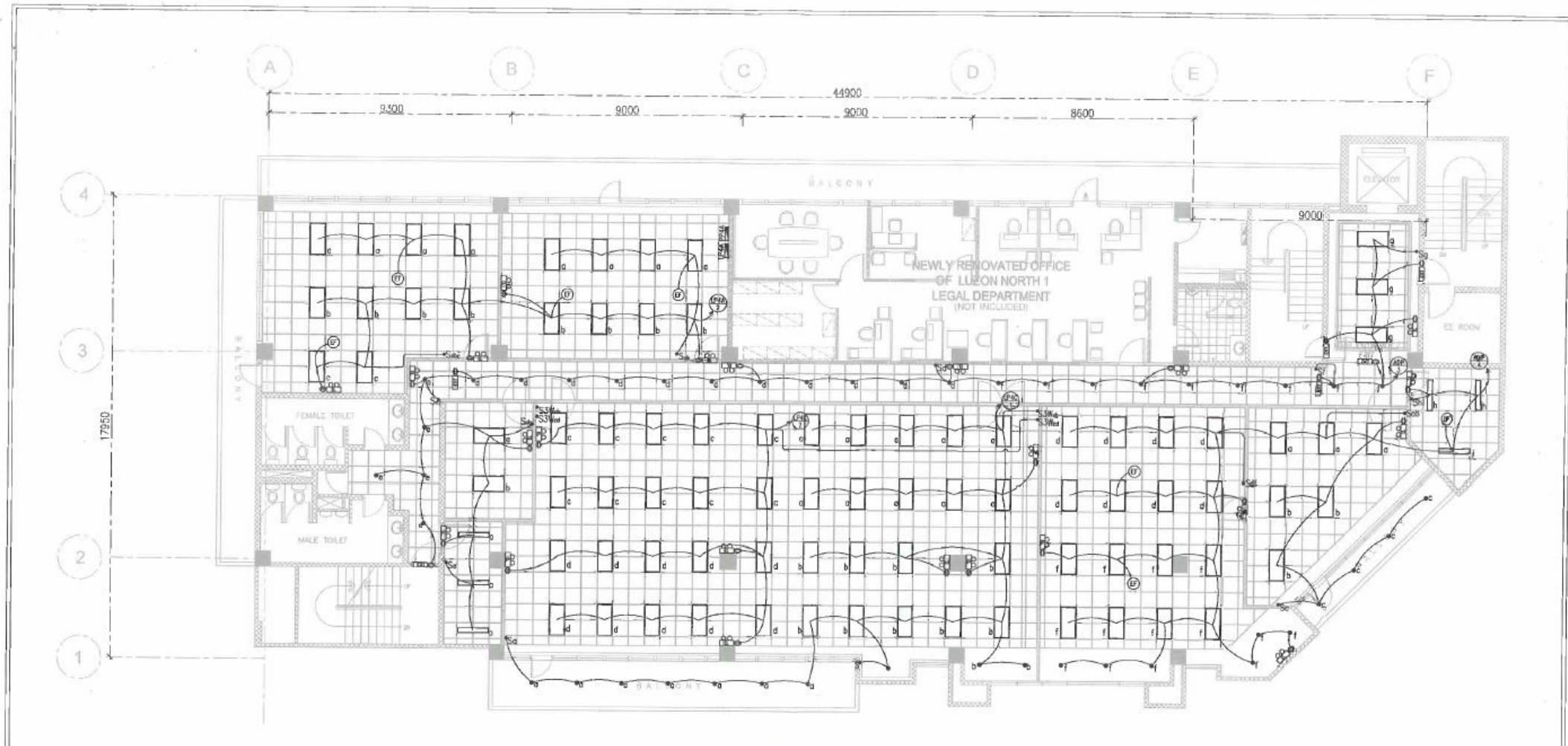

1 PROPOSED LIGHTING LAYOUT
 E-04 SCALE 1:150

 ENGINEERING AND FACILITIES MANAGEMENT DEPARTMENT SOCIAL SECURITY SYSTEM	PROJECT TITLE: PROPOSED RENOVATION OF SSS BAGUIO FOURTH FLOOR	RECOMMENDING APPROVAL:  STEPHEN P. YAP ACTING HEAD, EFMD	APPROVED AS USER/OWNER:  EDWIN B. MALAWAT ACTING HEAD, GSO	APPROVED FOR IMPLEMENTATION:  ANTONIO S. ARGABIOSO ACTING HEAD, LIAISON OPERATIONS GROUP	 JOHNSY L. MANGUNDAYAO VP, ACTING HEAD, ADMINISTRATION GROUP	ENGINEERING TEAM: DESIGNED & DRAWN BY: MARK A. Sagmay - SF, Analyst REVIEWED BY: George N. Garzon - SSO V, EMT-1	SHEET CONTENT: PROPOSED LIGHTING LAYOUT	ALL DRAWINGS MUST BE VERIFIED ON SITE BY THE C O N T R A S T I D P. ALL DISCREPANCIES SHOULD BE FORWARDED IMMEDIATELY TO THE ARCHITECT AND PROJECT MANAGERS. CONTRACTORS ARE TO FURNISH AND VERIFY SIZE OR DIMENSIONS TO THE ARCHITECT PRIOR TO COMMENCEMENT OF WORK.	SHEET NO.: E-04 DATE: JULY 13, 2020
	LOCATION: Fourth Floor, SSS Building, Harrison Road, Baguio City								

Renovation of 4th Floor (COA, RIMT Records Room, Network Room and Storage Room) and Various Improvements at Ground Floor (Info Kiosk, Electrical Room and Vault Room) at SSS Baguio Building

Handwritten signature

Section VIII. Bill of Quantities

PROJECT : Renovation of 4th Floor at SSS Baguio (COA, RIMT, Records Room Area, Network Room and Storage Room)

LOCATION : 4th Floor, SSS Baguio Building, Harisson Road, Baguio City

BILL OF QUANTITIES FORM (BOQ FORM)

ITEM	DESCRIPTION	QTY.	UNIT	MATERIALS		LABOR & EQUIPMENT		MOB. / DEMOB.	TOTAL DIRECT COST	MARK-UP	VAT	TOTAL COST
				UNIT COST	TOTAL	UNIT COST	TOTAL					
(A)	(B)	(C)	(D)	(E)	(F) (C * E)	(G)	(H) (C * G)	(I) % * (F+H)	(J) (F + H + I)	(K) % * (J)	(L) 12% * (J+K)	(M) (J + K + L)
1	GENERAL REQUIREMENTS											
1.01	Processing and Securing Renovation and Occupancy Permit including Fees and Reproduction of Signed and Sealed Plans, As-Built Plans	1.00	lot									
SUB-TOTAL 1 – GENERAL REQUIREMENTS												
2	SITE PREPARATION											
2.01	Temporary Facilities, Board-up/Enclosure, Safety Signages, Protective Covering Materials	1.00	lot									
2.02	Demolition/Dismantling Works which include Wall Partitions, Doors, Windows, Ceiling, Cabinets and other structures affected by the renovation works	1.00	lot									
2.03	Stripping / Dismantling of existing floor finishes	1.00	lot									
2.04	Hauling & Disposal of Debris & Waste Materials	1.00	lot									
SUB-TOTAL 2 – SITE PREPARATION												
3	CARPENTRY WORKS											
3.01	Construction of Ceiling											
	Construction of new 16mm thick acoustic ceiling board on CMT Powder Coated Aluminum Frame (COA Office, Office Space For Expansion, Elevator Lobby)	327.09	sq.m.									
	Installation of new 6mm thick fiber cement board ceiling on CMT Powder Coated Aluminum Frame (RIMT Records Room, COA Records Room, Storage Room for Building & Network Office, Network Room, Storage Room,)	207.23	sq.m.									
	Construction of new 6mm thick fiber cement board ceiling on light Metal Frames (Cove Ceiling, Balcony)	75.83	sq.m.									
3.02	Construction of Drywall Partition											
	Construction of Drywall Partition on Metal Studs Frame (COA Office, COA Records Room, Building Admin & Network Office, Data/Network Room, RIMT Records Rooms, Hallway)	151.67	sq.m.									

ITEM	DESCRIPTION	QTY.	UNIT	MATERIALS		LABOR & EQUIPMENT		MOB. / DEMOB.	TOTAL DIRECT COST	MARK-UP	VAT	TOTAL COST
				UNIT COST	TOTAL	UNIT COST	TOTAL					
(A)	(B)	(C)	(D)	(E)	(F) (C * E)	(G)	(H) (C * G)	(I) % * (F+H)	(J) (F + H + I)	(K) % * (J)	(L) 12% * (J+K)	(M) (J + K + L)
3.03	Supply & Installation of Wooden Doors											
	WD-01, 1.00 x 2.15m, flush hollow core wood door w/ bottom louver,including jambs, cylindrical lockset, door closer, hinges, complete w/ hardwares & accessories (Supplies Room, RIMT Records Room, Data/Network Room)	3.00	set									
	WD-02, 1.00 x 2.15m, flush hollow core wood door w/ vision glass & bottom louver including jambs, cylindrical lockset, door closer, hinges, complete w/ hardwares & accessories (COA Records Room, RIMT Records Room, Bldg. Admin. Storage Room))	3.00	set									
SUB-TOTAL 3 – CARPENTRY WORKS												
4	ARCHITECTURAL / SPECIALTY WORKS											
4.01	Supply & Installation of Glass Partitions, Doors & Windows											
	GP-01, 1.20m x 2.54m, 12mm thk Tempered Clear Glass Panels on FD 100 Top & Bottom Powder Coated Finish (COA Office)	1.00	set									
	GD-01, 1.00m x 2.54m, 12mm thk Tempered Clear Glass Single Leaf Doors on FD 100 Top & Bottom w/ Transom on Aluminum Frame w/ Stainless Steel Door Handles w/ Hardwares & Accessories (COA Office)	1.00	set									
4.02	Supply & Installation of Frosted Stickers/Signage											
	Vinyl Frosted Sticker/Signage, 1.20m x 1.20m (GP-01, COA Office)	1.00	set									
	Vinyl Frosted Sticker/Signage, 1.00m x 1.20m (GD-01, COA Office)	1.00	set									
4.03	Supply & Installation of Floor Finishes											
	600mm x 600mm Ceramic Floor Tiles Porcelain Finish (COA Office, COA Records Room, Office Space for Expansion, Building Admin & Network Office, Data/Network Room, RIMT Records Rooms, Hallway, Elevator Lobby)	575.02	sq.m.									
	300mm x 300mm Vinyl Floor Tiles (Hallway-for cable wires)	29.25	sq.m.									
4.04	Supply and Installation of indoor acrylic signages											
	Acrylic Signage, 0.75m x 0.15m, wall mounted (RIMT Records Room)	2.00	set									
	Acrylic Signage, 0.75m x 0.15m, wall mounted (Network Room)	1.00	set									
	Acrylic Signage, 0.75m x 0.15m, wall mounted (Supplies/Storage Room)	1.00	set									
	Acrylic Signage, 0.75m x 0.15m, wall mounted (COA Records Room)	1.00	set									
SUB-TOTAL 4 – ARCHITECTURAL / SPECIALTY WORKS												

ITEM	DESCRIPTION	QTY.	UNIT	MATERIALS		LABOR & EQUIPMENT		MOB. / DEMOB.	TOTAL DIRECT COST	MARK-UP	VAT	TOTAL COST
				UNIT COST	TOTAL	UNIT COST	TOTAL					
(A)	(B)	(C)	(D)	(E)	(F) (C * E)	(G)	(H) (C * G)	(I) % * (F+H)	(J) (F + H + I)	(K) % * (J)	(L) 12% * (J+K)	(M) (J + K + L)
5	PAINTING WORKS											
5.01	Surface preparation of all painting works (sanding, application of putty, easy tite, primer)	1.00	lot									
5.02	Painting of new drywall partitions	329.76	sq.m.									
5.03	Painting of existing drywall / masonry walls	197.90	sq.m.									
5.04	Painting of Ficem Board Ceiling	248.76	sq.m.									
5.05	Painting of wooden doors and jambs (ducco finish)	6.00	set									
5.06	Painting of metal / wood surfaces (existing windows/doors, diffusers, louvers, cornices, baseboards)	1.00	lot									
	SUB-TOTAL 5 – PAINTING WORKS											
6	ELECTRICAL WORKS											
6.01	Conduits & Fittings											
	20mmØ PVC Pipe	365.00	L									
	20mmØ PVC complete fittings and accessories such as but not limited to: a. coupling adapter/connector b. locknut and bushing c. c-clamps d. screws	1.00	Lot									
	25mmØ IMC Pipe	4.00	L									
	25mmØ IMC complete fittings and accessories such as but not limited to: a. coupling adapter/connector b. locknut and bushing c. c-clamps d. screws	1.00	Lot									
	50mmØ IMC Pipe	2.00	L									
	50mmØ IMC complete fittings and accessories such as but not limited to: a. coupling adapter/connector b. locknut and bushing c. c-clamps d. screws	1.00	Lot									
	20mmØ Flexible Metal Conduit	254.00	Lm.									
	20mmØ Flexible Metal Conduit complete fittings and accessories such as but not limited to: a. Flexible Straight Connector b. Locknut and bushing c. Angle Connector d. c-clamps e. screws	1.00	Lot									
6.02	Boxes / Wiregutter, w/ powder coated gray paint											
	PVC Junction Box w/ plate cover, Deep type, with screws	241.00	EA									
	PVC Utility Box, Deep Type, with screws	74.00	EA									

ITEM	DESCRIPTION	QTY.	UNIT	MATERIALS		LABOR & EQUIPMENT		MOB. / DEMOB. (I) % * (F+H)	TOTAL DIRECT COST (J) (F + H + I)	MARK-UP (K) % * (J)	VAT (L) 12% * (J+K)	TOTAL COST (M) (J + K + L)
				UNIT COST (E)	TOTAL (F) (C * E)	UNIT COST (G)	TOTAL (H) (C * G)					
6.03	Wires / Cables											
	3.5mm2 THHN wire (lead free)	3,500.00	Lm.									
	5.5mm2 THHN wire (lead free)	168.00	Lm.									
	8.0mm2 THHN wire (lead free)	191.00	Lm.									
	14.0mm2 THHN wire (lead free)	65.00	Lm.									
6.04	Wiring Devices/ Lighting Fixtures											
	Duplex Convenience Outlet w/ ground/ 3- Prong, 20A, 240V, 2P,	56.00	Sets									
	One gang switch, single pole, 15A, 250V, flush type, metallic white	8.00	Sets									
	Two gang switch, single pole, 15A, 250V, flush type, metallic white	5.00	Sets									
	Three gang switch, single pole, 15A, 250V, flush type, metallic white	1.00	Sets									
	Three gang, Three way switch, single pole, 15A, 250V, flush type, metallic white	4.00	Sets									
	Recessed Panel type LED lighting fixture 1200x300, 24W,220V, Cool Daylight	6.00	Sets									
	Recessed Panel type LED lighting fixture 1200x600, 32W,220V, Cool Daylight	84.00	Sets									
	Recessed Round Slim LED Panel type lighting fixture, 18W,220V, Cool Daylight	47.00	Sets									
	Tubular Type Exhaust Fan, 40W, 1Phase, 230Volts, 60Hz, size (10"x10") grided, 200 cfm min.	7.00	Sets									
	Fire Exit Light signage, 5W, 6Vdc with back-up battery rechargeable, LED Bulb	6.00	Sets									
	Emergency Light, 2X2W(Min.), 220V, Lead Acid Battery with C.O	23.00	Sets									
6.05	Circuit Protection, Panel boards, Enclosed Circuit Breaker											
	PP4C Main: 200AT, 3P, 32 kAIC, 230V Branch: 1-70AT, 3P, 18 kAIC, 230V 5-60AT, 3P, 18 kAIC, 230V	1.00	Assy.									
	LP4C Main: 70AT, 3P, 18 kAIC, 230V Branch: 12-20AT, 2P, 10 kAIC, 230V Surface Mounted, Industrial Type, w/ grounding terminal block, powder coated gray paint	1.00	Assy.									
6.06	Conduit supports, hangers, pull boxes, gutters, cable trays, angle bars, U bolts with nuts, threaded Rod 3/8", Dyna-anchore bolts, expansion shield and lug screws and other miscellaneous consumable materials and other incidental services for the completion of the project.	1.00	Lot									
6.07	Dismantling of all existing Electrical wiring devices, conduits, wirings, boxes and panels not necessary to the project including chipping works and testing and commissioning.	1.00	Lot									
SUB-TOTAL 6- ELECTRICAL WORKS												

ITEM	DESCRIPTION	QTY.	UNIT	MATERIALS		LABOR & EQUIPMENT		MOB. / DEMOB.	TOTAL DIRECT COST	MARK-UP	VAT	TOTAL COST
				UNIT COST	TOTAL	UNIT COST	TOTAL					
(A)	(B)	(C)	(D)	(E)	(F) (C * E)	(G)	(H) (C * G)	(I) % * (F+H)	(J) (F + H + I)	(K) % * (J)	(L) 12% * (J+K)	(M) (J + K + L)
7	STRUCTURED CABLING WORKS											
7.01	Cabling Components											
	Cat 5E Information Outlet	16.00	pcs									
	Cat 5e Patch Panel 24 ports	1.00	pc									
	Cable Manager	1.00	pc									
	Modular Faceplate 2-port	8.00	pcs									
	Cat 5E UTP Cable 4-pair solid, 24AWG (305m/spool)	4.00	spool									
7.02	Roughing-ins											
	Metal flexible, junction/square/pull box, Plastic Box, angle bar, anchor bolt, IMC/RSC pipes, misc. item, etc.	1.00	Lot									
	SUB-TOTAL 7 – STRUCTURED CABLING WORKS											
	TOTAL PROJECT COST											

Ceiling Amount is P 4,399,391.00. Any bid with financial component exceeding this amount shall be considered non-responsive.

GENERAL CONDITIONS:

- For uniformity and evaluation purposes, a bidder shall adhere to the herein prescribed format of BOQ, specifically in the formula for computation, given quantity and inclusive pay items. Any deviation from the format shall be a ground for disqualification of bid.
 - Fill up all required items/field in the BOQ. Failure to indicate any of the following shall mean outright disqualification since bid is considered Non-responsive:
 - * if item is given for free, indicate dash (-), zero (0) or free
 - * If the item is not applicable, indicate N/A
- Each bidder shall be provided with hard copy of the BOQ Form (attached in the PBD) and an electronic copy (CD) for faster and easier encoding. The hard copy shall serve as the bidder's reference as to completeness of work items, quantity, formula, format, etc. in the BOQ Form considering that the electronic copy is prone to alterations during encoding. Any discrepancy on the contents (specially on the quantity and inclusive pay items) between the hard copy and electronic copy, the contents of the hard copy shall prevail.
- Bidders are not allowed to include any pay items that were not indicated in the hard copy of BOQ. In instances where necessary work items are inadvertently left out in BOQ Form, a bidder should make a written query to the Bids and Awards Committee so that the same shall be addressed in the Bid Bulletin which will be issued to all participating bidders.
- All documents must be signed, and each and every page thereof must be initialed by the duly authorized representative/s of the Bidder.
- Mark-up shall include the following:
 - Overhead expenses such as office expenses, supervision, transportation allowances, and financing costs (Premium on CARI, Bid Security, Performance Security, Surety for advance payment, Warranty bond)
 - Contingencies, Miscellaneous Expenses and Contractor's Profit margin
- It is the responsibility of the Bidder to check the arithmetical computation provided herein.

SUBMITTED BY:

(Name of Bidder)

Address

PREPARED BY:

(Company Representative / Signature over printed name)

Telephone Number

Date

**Various Improvements at SSS Baguio
 (Info kiosk, Electrical room and Vault at Ground floor)**

PROJECT : Various Improvement at SSS Baguio (info kiosk, electrical room and vault at ground floor)
LOCATION : Ground Floor, SSS Baguio Building, Harisson Road, Baguio City

BILL OF QUANTITIES FORM (BOQ FORM)

ITEM	DESCRIPTION	QTY.	UNIT	MATERIALS		LABOR & EQUIPMENT		MOB. / DEMOB.	TOTAL DIRECT COST	MARK-UP	VAT	TOTAL COST
				UNIT COST	TOTAL	UNIT COST	TOTAL					
(A)	(B)	(C)	(D)	(E)	(F) (C * E)	(G)	(H) (C * G)	(I) % * (F+H)	(J) (F + H + I)	(K) % * (J)	(L) 12% * (J+K)	(M) (J + K + L)
1	CARPENTRY WORKS											
1.01	Installation of Ceiling (Vault, Electrical Room and Info Kiosk) 6mm thk FICEM CEILING BD. (Vault, Electrical Room and Info Kiosk)	17.53	sq.m.									
	SUB-TOTAL 1 – CARPENTRY WORKS											
2	ARCHITECTURAL FINISHES											
2.01	CERAMIC TILES Porcelain Finish (Vault, Electrical Room and Info Kiosk)	18.30	sq.m.									
	SUB-TOTAL 2 – ARCHITECTURAL FINISHES											
3	PAINTING WORKS											
3.01	Painting of masonry wall surfaces	74.62	sq.m.									
	SUB-TOTAL 3 – PAINTING WORKS											
4	DOORS AND WINDOWS											
4.01	SD-01 - Steel Door Aluminum Roll-Up security Grills 5/6" ø Solid Horizontal Aluminum Rods Spaced @ 2 1/2" O.C. 5/8" Vertical Aluminum Links spaced @ 9" O.C. complete with accessories	2.00	set									
4.02	SD-02 - 900 x 2150 mm steel Door Flush Hollow Core Steel Door w/ Lever Type Lockset & Dead Bolt & Bottom Louver, Complete w/ hardwares and accessories	1.00	set									
4.03	WD-01 - Wood Door Flush Hollow Core wood Door w/ Cylindrical Lockset & Door Closer, complete w/ Hardwares & accessories	1.00	set									
4.04	GD-01 - 800 x 2600mm 1 Leaf Door w/ Transom w/ 12mm thk Temp. Glass on Analok Alum. Fr. - (GF SSIT Entrance)	2.00	set									
4.05	GLASS STORE FRONT - 6mm Temp. Glass on Analok Alum. Fr. (GF) - 0.800m x 0.360m	2.00	set									
4.06	GLASS STORE FRONT - 6mm Temp. Glass on Analok Alum. Fr. (GF) - 1.150m x 2.560	2.00	set									
	SUB-TOTAL 4 – DOORS AND WINDOWS											

ITEM	DESCRIPTION	QTY.	UNIT	MATERIALS		LABOR & EQUIPMENT		MOB. / DEMOB. (I) % * (F+H)	TOTAL DIRECT COST (J) (F + H + I)	MARK-UP (K) % * (J)	VAT (L) 12% * (J+K)	TOTAL COST (M) (J + K + L)
				UNIT COST (E)	TOTAL (F) (C * E)	UNIT COST (G)	TOTAL (H) (C * G)					
5	SPECIALTY WORKS											
5.01	GLASS STORE FRONT 1 & 2											
	- Frosted Vinyl Sticker, 0.400m L x 0.200m H (0.861sq. ft.)	4.00	set									
	- Frosted Vinyl Sticker, 0.400m L x 0.750m H (3.228sq. ft.)	2.00	set									
	SUB-TOTAL 5 – SPECIALTY WORKS											
6	ELECTRICAL WORKS											
6.01	CONDUITS & FITTINGS											
	15mmØ IMC Locknut and bushing	6.00	pairs									
	15mmØ Flexible Metallic Conduit	3.00	lm									
6.02	BOXES, WIRES, & GUTTERS PC Gray Paint											
	PVC Junction Box w/ plate cover	4.00	EA									
6.03	WIRES & CABLES											
	3.5mm ² THHN wire (lead free)	3.00	lm									
6.04	WIRING DEVICES & LIGHTING FIXTURES											
	150mmØ Recessed type Spun Alum., specular finish Pinlight w/ Semi- F Concave Glass cover w/ mounting ring, cash Alum., comp. w/ 9W LED Bulb in white PC finished	3.00	sets									
	SUB-TOTAL 6– ELECTRICAL WORKS											
7	STRUCTURED CABLING WORKS											
7.01	CABLING COMPONENTS											
	Cat 5E UTP Cable 4-pair solid, 24AWG (305m / spool)	1.00	spool									
	Cat 5E UTP Cable 4-pair stranded, 24AWG (305m / spool)	1.00	spool									
7.02	ROUGHING INS											
	Cable Raceway enamel coated, metal flexible, junction/square/pull box, plastic box, angle bar, anchor bolt,IMC and PVC pipe, service cap, misc. items, etc.	1.00	lot									
	SUB-TOTAL 7 – STRUCTURED CABLING WORKS											
	TOTAL PROJECT COST											

Ceiling Amount is P 340,615.00. Any bid with financial component exceeding this amount shall be considered non-responsive.

GENERAL CONDITIONS:

1. For uniformity and evaluation purposes, a bidder shall adhere to the herein prescribed format of BOQ, specifically in the formula for computation, given quantity and inclusive pay items. Any deviation from the format shall be a ground for disqualification of bid.
1.1 Fill up all required items/field in the BOQ. Failure to indicate any of the following shall mean outright disqualification since bid is considered Non-
* if item is given for free, indicate dash (-), zero (0) or free
* If the item is not applicable, indicate N/A
2. Each bidder shall be provided with hard copy of the BOQ Form (attached in the PBD) and an electronic copy (CD) for faster and easier encoding. The hard copy shall serve as the bidder's reference as to completeness of work items, quantity, formula, format, etc. in the BOQ Form considering that the electronic copy is prone to alterations during encoding. Any discrepancy on the contents (specially on the quantity and inclusive pay items) between the hard copy and electronic copy, the contents of the hard copy shall prevail.
3. Bidders are not allowed to include any pay items that were not indicated in the hard copy of BOQ. In instances where necessary work items are inadvertently left out in BOQ Form, a bidder should make a written query to the Bids and Awards Committee so that the same shall be addressed in the Bid Bulletin which will be issued to all participating bidders.
4. All documents must be signed, and each and every page thereof must be initialed by the duly authorized representative/s of the Bidder.
5. Mark-up shall include the following:
5.1 Overhead expenses such as office expenses, supervision, transportation allowances, and financing costs (Premium on CARI, Bid Security, Performance Security, Surety for advance payment, Warranty bond)
5.2 Contingencies, Miscellaneous Expenses and Contractor's Profit margin
6. It is the responsibility of the Bidder to check the arithmetical computation provided herein.

SUBMITTED BY:

(Name of Bidder)

Address

PREPARED BY:

(Company Representative / Signature over printed name)

Telephone Number

Date



Section IX. Checklist of Technical and Financial Documents

Checklist of Technical and Financial Documents

I. TECHNICAL COMPONENT ENVELOPE

Class "A" Documents

Legal Documents

- (a) Valid PhilGEPS Registration Certificate (Platinum Membership) (all pages);
or
- (b) Registration certificate from Securities and Exchange Commission (SEC), Department of Trade and Industry (DTI) for sole proprietorship, or Cooperative Development Authority (CDA) for cooperatives or its equivalent document;
and
- (c) Mayor's or Business permit issued by the city or municipality where the principal place of business of the prospective bidder is located, or the equivalent document for Exclusive Economic Zones or Areas;
and
- (d) Tax clearance per E.O. No. 398, s. 2005, as finally reviewed and approved by the Bureau of Internal Revenue (BIR).

Technical Documents

- (e) Statement of the prospective bidder of all its ongoing government and private contracts, including contracts awarded but not yet started, if any, whether similar or not similar in nature and complexity to the contract to be bid; **and**
- (f) Statement of the bidder's Single Largest Completed Contract (SLCC) similar to the contract to be bid, except under conditions provided for in Sections 23.4.1.3 and 23.4.2.4 of the 2016 revised IRR of RA No. 9184, **within _____ period** prior to the submission and opening of Bids; **and**
- (g) Philippine Contractors Accreditation Board (PCAB) License;
or
Special PCAB License in case of Joint Ventures;
and registration for the type and cost of the contract to be bid; **and**
- (h) Original copy of Bid Security. If in the form of a Surety Bond, submit also a certification issued by the Insurance Commission;
or
Original copy of Notarized Bid Securing Declaration; **and**
- (i) Project Requirements, which shall include the following:
 - a. Organizational chart for the contract to be bid;
 - b. List of contractor's key personnel (*e.g.*, Project Manager, Project Engineers, Materials Engineers, and Foremen), to be assigned to the contract to be bid, with their complete qualification and experience data;
 - c. List of contractor's major equipment units, which are owned, leased, and/or under purchase agreements, supported by proof of ownership or certification of availability of equipment from the equipment lessor/vendor for the duration of the project, as the case may be; **and**
- (j) Original duly signed Omnibus Sworn Statement (OSS);
and if applicable, Original Notarized Secretary's Certificate in case of a corporation, partnership, or cooperative; or Original Special Power of Attorney of all members of the joint venture giving full power and authority to its officer to sign the OSS and do acts to represent the Bidder.

Financial Documents

- (k) The prospective bidder's audited financial statements, showing, among others, the prospective bidder's total and current assets and liabilities, stamped "received" by the BIR or its duly accredited and authorized institutions, for the preceding calendar year which should not be earlier than two (2) years from the date of bid submission; **and**
- (l) The prospective bidder's computation of Net Financial Contracting Capacity

(NFCC).

Class "B" Documents

- (m) If applicable, duly signed joint venture agreement (JVA) in accordance with RA No. 4566 and its IRR in case the joint venture is already in existence;
or
duly notarized statements from all the potential joint venture partners stating that they will enter into and abide by the provisions of the JVA in the instance that the bid is successful.

II. FINANCIAL COMPONENT ENVELOPE

- (n) Original of duly signed and accomplished Financial Bid Form; **and**

Other documentary requirements under RA No. 9184

- (o) Original of duly signed Bid Prices in the Bill of Quantities; **and**
 (p) Duly accomplished Detailed Estimates Form, including a summary sheet indicating the unit prices of construction materials, labor rates, and equipment rentals used in coming up with the Bid; **and**
 (q) Cash Flow by Quarter.

IMPORTANT REMINDERS

- A) Each and every page of the Bid Forms, under Section VIII: Checklist of Technical and Financial Documents hereof, shall be signed by the duly authorized representative/s of the Bidder. Failure to do so shall be a ground for the rejection of the bid.
- B) Any interlineations, erasures, or overwriting shall be valid only if they are signed or initialed by the duly authorized representative/s of the Bidder.
- C) Bid documents shall be compiled in a folder/binder with the Annexes properly labeled with tabs/separators.
- D) Bidders shall submit their bids through their duly authorized representative enclosed in separate sealed envelopes, which shall be submitted simultaneously:
- a) The first three individually sealed envelopes shall contain the folder/binder of the Eligibility Requirements and Technical Component of the bid; prepared in three copies labeled as follows:
- Envelop (1): ORIGINAL – Eligibility Requirements and Technical Component
Envelop (2): COPY1 – Eligibility Requirements and Technical Component
Envelop (3): COPY2 – Eligibility Requirements and Technical Component
- b) The next three individually sealed envelopes shall contain the folder/binder of the Financial Component of the bid; prepared in three copies labeled as follows:
- Envelop (4): ORIGINAL – Financial Component
Envelop (5): COPY1 – Financial Component
Envelop (6): COPY2 – Financial Component
- c) Bidders shall enclose, seal and mark the following:
- Envelop (7): Envelope (1) and Envelope (4) enclosed in one sealed envelope marked "ORIGINAL-BID"
- Envelop (8): Envelope (2) and Envelope (5) enclosed in one sealed envelope marked "COPY1-BID"
- Envelop (9): Envelope (3) and Envelope (6) enclosed in one sealed envelope marked "COPY2-BID"
- d) Envelopes (7) to (9) shall then be enclosed in a single sealed, signed final/outer envelope/package/box

- e) All envelopes (Envelopes (1) to (9) and the final/outer envelope/package/box) shall indicate the following:
- addressed to the Procuring Entity’s BAC
 - name and address of the Bidder in capital letters
 - name of the contract/project to be bid in capital letters
 - bear the specific identification/reference code of this bidding process
 - bear a warning “DO NOT OPEN BEFORE...” the date and time for the opening of bids

<p>THE CHAIRPERSON</p> <p>BIDS AND AWARDS COMMITTEE</p> <p>2ND FLOOR, SSS MAIN BUILDING</p> <p>EAST AVENUE, DILIMAN, QUEZON CITY</p> <p>NAME OF BIDDER : _____</p> <p>ADDRESS : _____</p>
--

- E) Bids submitted after the deadline shall only be marked for recording purpose, shall not be included in the opening of bids, and shall be returned to the bidder unopened.
- F) Bidders shall submit a copy of the Authority to Notarize issued by the Regional Trial Court to the Notarial Public.



FORMS

Bid Form for the Procurement of Infrastructure Projects

BID FORM

Renovation of 4th Floor (COA, RIMT Records Room, Network Room and Storage Room) and Various Improvements at Ground Floor (Info Kiosk, Electrical Room and Vault Room) at SSS Baguio Building

Date: _____
Project Identification No.: _____

To: SOCIAL SECURITY SYSTEM
East Avenue, Diliman, Quezon City

Having examined the Philippine Bidding Documents (PBDs) including the Supplemental or Bid Bulletin Numbers [insert numbers], the receipt of which is hereby duly acknowledged, we, the undersigned, declare that:

- a. We have no reservation to the PBDs, including the Supplemental or Bid Bulletins, for the Procurement Project: **(Insert name of contract)**;
- b. We offer to execute the Works for this Contract in accordance with the PBDs;
- c. The total price of our Bid in words and figures, excluding any discounts offered below is: **(insert information)**;
- d. The discounts offered and the methodology for their application are: **(insert information)**;
- e. The total bid price includes the cost of all taxes, such as, but not limited to: [specify the applicable taxes, e.g. (i) value added tax (VAT), (ii) income tax, (iii) local taxes, and (iv) other fiscal levies and duties], which are itemized herein and reflected in the detailed estimates,
- f. Our Bid shall be valid within the period stated in the PBDs, and it shall remain binding upon us at any time before the expiration of that period;
- g. If our Bid is accepted, we commit to obtain a Performance Security in the amount of **[insert percentage amount]** percent of the Contract Price for the due performance of the Contract, or a Performance Securing Declaration in lieu of the allowable forms of Performance Security, subject to the terms and conditions of issued GPPB guidelines for this purpose;
- h. We are not participating, as Bidders, in more than one Bid in this bidding process, other than alternative offers in accordance with the Bidding Documents;
- i. We understand that this Bid, together with your written acceptance thereof included in your notification of award, shall constitute a binding contract between us, until a formal Contract is prepared and executed; and
- j. We understand that you are not bound to accept the Lowest Calculated Bid or any other Bid that you may receive.
- k. We likewise certify/conform that the undersigned, is the duly authorized representative of the bidder, and granted full power and authority to do, execute and perform any and all acts necessary to participate, submit the bid, and to sign and execute the ensuing contract for the **(Name of Project)** of the [Name of the Procuring Entity].



1. We acknowledge that failure to sign each and every page of this Bid Form, including the Bill of Quantities, shall be a ground for the rejection of our bid.

Name: _____

Legal capacity: _____

Signature: _____

Duly authorized to sign the Bid for and behalf of _____

Date: _____

GPPB Resolution No. 16-2020, dated 16 September 2020

Bid Securing Declaration Form

REPUBLIC OF THE PHILIPPINES) CITY OF
_____) S.S.

BID SECURING DECLARATION

Project Identification No.: [Insert number]

To: *[Insert name and address of the Procuring Entity]*

I/We, the undersigned, declare that:

1. I/We understand that, according to your conditions, bids must be supported by a Bid Security, which may be in the form of a Bid Securing Declaration.
2. I/We accept that: (a) I/we will be automatically disqualified from bidding for any procurement contract with any procuring entity for a period of two (2) years upon receipt of your Blacklisting Order; and, (b) I/we will pay the applicable fine provided under Section 6 of the Guidelines on the Use of Bid Securing Declaration, within fifteen (15) days from receipt of the written demand by the procuring entity for the commission of acts resulting to the enforcement of the bid securing declaration under Sections 23.1(b), 34.2, 40.1 and 69.1, except 69.1(f), of the IRR of RA No. 9184; without prejudice to other legal action the government may undertake.
3. I/We understand that this Bid Securing Declaration shall cease to be valid on the following circumstances:
 - a. Upon expiration of the bid validity period, or any extension thereof pursuant to your request;
 - b. I am/we are declared ineligible or post-disqualified upon receipt of your notice to such effect, and (i) I/we failed to timely file a request for reconsideration or (ii) I/we filed a waiver to avail of said right; and
 - c. I am/we are declared the bidder with the Lowest Calculated Responsive Bid, and I/we have furnished the performance security and signed the Contract.

IN WITNESS WHEREOF, I/We have hereunto set my/our hand/s this ____ day of *[month]*
[year] at *[place of execution]*.

*[Insert NAME OF BIDDER OR ITS AUTHORIZED
REPRESENTATIVE]
[Insert signatory's legal capacity] Affiant*

[Jurat]

[Format shall be based on the latest Rules on Notarial Practice]

GPPB Resolution No. 16-2020, dated 16 September 2020

**Contract Agreement Form for the
Procurement of Infrastructure Projects (Revised)**

CONTRACT AGREEMENT

ITB-SSS-CIVIL-2022-__

THIS AGREEMENT made between:

SOCIAL SECURITY SYSTEM, a government-owned and controlled corporation created pursuant to Republic Act No. 11199, with principal office address at SSS Building, East Avenue, Diliman, Quezon City, represented herein by its Approving Authority and (Position of Approving Authority), (Name of Approving Authority) and (Position of Signatory), (Name of signatory), duly authorized pursuant to Administrative Order _____, _____ (pertaining to Approving Authority) (Annex “A”) and Office Order _____, _____ (Annex “B”) (pertaining to signatories), hereinafter referred to as the “SSS”;

- a n d -

(NAME OF CONTRACTOR), of legal age, Filipino, single/married, with principal address at _____, hereinafter referred to as the “Contractor”.

If corporation

(NAME OF CONTRACTOR), a corporation duly created and existing pursuant to the laws of the Republic of the Philippines, with principal office address at _____, represented herein by its (Position of Signatory), (Name of Signatory), duly authorized pursuant to _____, _____, hereinafter referred to as the “Contractor”.

WHEREAS, the Entity is desirous that the Contractor execute [name and identification number of contract] (hereinafter called “the Works”) and the Entity has accepted the Bid for [contract price in words and figures in specified currency] by the Contractor for the execution and completion of such Works and the remedying of any defects therein.

NOW THIS AGREEMENT WITNESSETH AS FOLLOWS:

1. In this Agreement words and expressions shall have the same meanings as are respectively assigned to them in the Conditions of Contract referred to.
2. The following documents as required by the 2016 revised Implementing Rules and Regulations of Republic Act No. 9184 shall be deemed to form and be read and construed as integral part of this Agreement, viz.:
 - a. Philippine Bidding Documents (PBDs);
 - i. Drawings/Plans;
 - ii. Specifications;
 - iii. Bill of Quantities;
 - iv. General and Special Conditions of Contract;
 - v. Supplemental or Bid Bulletins, if any

- b. Contractor's bidder's bid, including the Eligibility requirements, Technical and Financial Proposals, and all other documents or statements submitted;

Bid form, including all the documents/statements contained in the Bidder's bidding envelopes, as annexes, and all other documents submitted (e.g., Bidder's response to request for clarifications on the bid), including corrections to the bid, if any, resulting from the Procuring Entity's bid evaluation;

- c. Performance Security;

- d. Notice of Award of Contract; and the Bidder's conforme thereto; and

- e. Other contract documents that may be required by existing laws and/or the Procuring Entity concerned in the PBDs. **Winning bidder agrees that additional contract documents or information prescribed by the GPPB that are subsequently required for submission after the contract execution, such as the Notice to Proceed, Variation Orders, and Warranty Security, shall likewise form part of the Contract.**

- 3. In consideration for the sum of *[total contract price in words and figures]* or such other sums as may be ascertained, *[Named of the bidder]* agrees to *[state the object of the contract]* in accordance with his/her/its Bid.
- 4. The SSS agrees to pay the above-mentioned sum in accordance with the terms of the Bidding.

IN WITNESS whereof the parties hereto have caused this Agreement to be executed in accordance with the laws of the Republic of the Philippines on the day and year first above written.

[Insert Name and Signature]

[Insert Name and Signature]

[Insert Signatory's Legal Capacity]

[Insert Signatory's Legal Capacity]

for:

for:

SSS

[Insert Name of Supplier]

(In case of double acknowledgment)



SIGNED IN THE PRESENCE OF:

(Name of Certifying officer as to availability of funds)
(Position of Certifying Officer)
(Department/Office of Certifying Officer)

FUNDS AVAILABLE:

APP No.: _____

FIRST ACKNOWLEDGMENT

Republic of the Philippines)
_____) S.S.

BEFORE ME, a Notary Public for and in _____, Philippines, on this _____ day of _____ personally appeared:

Name	Competent Evidence of Identity	Date/Place of Issue

known to me to be the same person who executed the foregoing Agreement, consisting of _____ (___) pages, including this page and excluding annexes, and he/she/they acknowledged to me that the same is his/her/their free and voluntary act and deed as well as the free and voluntary act and deed of the principal he/she /they represent/s in this instance.

WITNESS MY HAND AND SEAL on the date and place first above written.

Doc. No. _____;
Page No. _____;
Book No. _____;
Series of 20__.



SIGNED IN THE PRESENCE OF:

SECOND ACKNOWLEDGMENT

Republic of the Philippines)
_____) S.S.

BEFORE ME, a Notary Public for and in _____, Philippines, on this _____ day of _____ personally appeared:

Name	Competent Evidence of Identity	Date/Place of Issue

known to me to be the same person who executed the foregoing Agreement, consisting of _____ (____) pages, including this page and excluding annexes, and he/she/they acknowledged to me that the same is his/her/their free and voluntary act and deed (if **corporation to include succeeding phrase**) as well as the free and voluntary act and deed of the principal he/she /they represent/s in this instance.

WITNESS MY HAND AND SEAL on the date and place first above written.

Doc. No. _____;
Page No. _____;
Book No. _____;
Series of 20__.



Omnibus Sworn Statement (Revised)

REPUBLIC OF THE PHILIPPINES)
CITY/MUNICIPALITY OF _____) S.S.

AFFIDAVIT

I, *[Name of Affiant]*, of legal age, *[Civil Status]*, *[Nationality]*, and residing at *[Address of Affiant]*, after having been duly sworn in accordance with law, do hereby depose and state that:

1. **Select one, delete the other:**

[If a sole proprietorship:] I am the sole proprietor or authorized representative of *[Name of Bidder]* with office address at *[address of Bidder]*;

[If a partnership, corporation, cooperative, or joint venture:] I am the duly authorized and designated representative of *[Name of Bidder]* with office address at *[address of Bidder]*;

2. **Select one, delete the other:**

[If a sole proprietorship:] As the owner and sole proprietor, or authorized representative of *[Name of Bidder]*, I have full power and authority to do, execute and perform any and all acts necessary to participate, submit the bid, and to sign and execute the ensuing contract for *[Name of the Project]* of the *[Name of the Procuring Entity]* as shown in the attached duly notarized Special Power of Attorney;

[If a partnership, corporation, cooperative, or joint venture:] I am granted full power and authority to do, execute and perform any and all acts necessary to participate, submit the bid, and to sign and execute the ensuing contract for *[Name of the Project]* of the *[Name of the Procuring Entity]*, as shown in the attached [state title of attached documents showing proof of authorization (e.g., duly notarized Secretary’s Certificate, Board/Partnership Resolution, or Special Power of Attorney, whichever is applicable;)];

3. *[Name of Bidder]* is not “blacklisted” or barred from bidding by the Government of the Philippines or any of its agencies, offices, corporations, or Local Government Units, foreign government/foreign or international financing institution whose blacklisting rules have been recognized by the Government Procurement Policy Board, **by itself or by relation, membership, association, affiliation, or controlling interest with another blacklisted person or entity as defined and provided for in the Uniform Guidelines on Blacklisting;**

4. Each of the documents submitted in satisfaction of the bidding requirements is an authentic copy of the original, complete, and all statements and information provided therein are true and correct;

5. *[Name of Bidder]* is authorizing the Head of the Procuring Entity or its duly authorized representative(s) to verify all the documents submitted;

6. **Select one, delete the rest:**

[If a sole proprietorship:] The owner or sole proprietor is not related to the Head of the Procuring Entity, members of the Bids and Awards Committee (BAC), the Technical Working Group, and the BAC Secretariat, the head of the Project Management Office or the end-user unit, and the project consultants by consanguinity or affinity up to the third civil degree;

[If a partnership or cooperative:] None of the officers and members of *[Name of Bidder]* is related to the Head of the Procuring Entity, members of the Bids and Awards Committee (BAC), the Technical Working Group, and the BAC Secretariat, the head of the Project Management Office or the end-user unit, and the project consultants by consanguinity or affinity up to the third civil degree;

[If a corporation or joint venture:] None of the officers, directors, and controlling stockholders of *[Name of Bidder]* is related to the Head of the Procuring Entity, members of the Bids and Awards Committee (BAC), the Technical Working Group, and the BAC Secretariat, the head of the Project Management Office or the end-user unit, and the project consultants by consanguinity or affinity up to the third civil degree;

7. *[Name of Bidder]* complies with existing labor laws and standards; and
8. *[Name of Bidder]* is aware of and has undertaken the responsibilities as a Bidder in compliance with the Philippine Bidding Documents, which includes:
 - a) Carefully examining all of the Bidding Documents;
 - b) Acknowledging all conditions, local or otherwise, affecting the implementation of the Contract;
 - c) Making an estimate of the facilities available and needed for the contract to be bid, if any; and
 - d) Inquiring or securing Supplemental/Bid Bulletin(s) issued for the *[Name of the Project]*.
9. *[Name of Bidder]* did not give or pay directly or indirectly, any commission, amount, fee, or any form of consideration, pecuniary or otherwise, to any person or official, personnel or representative of the government in relation to any procurement project or activity.
10. **In case advance payment was made or given, failure to perform or deliver any of the obligations and undertakings in the contract shall be sufficient grounds to constitute criminal liability for Swindling (Estafa) or the commission of fraud with unfaithfulness or abuse of confidence through misappropriating or converting any payment received by a person or entity under an obligation involving the duty to deliver certain goods or services, to the prejudice of the public and the government of the Philippines pursuant to Article 315 of Act No. 3815 s.1930, as amended, or the Revised Penal Code.**

IN WITNESS WHEREOF, I have hereunto set my hand this ___ day of ___, 20__ at _____, Philippines.

[Insert NAME OF BIDDER OR ITS AUTHORIZED REPRESENTATIVE]

[Insert signatory's legal capacity]

Affiant

[Jurat]

[Format shall be based on the latest Rules on Notarial Practice]

GPPB Resolution No. 16-2020, dated 16 September 2020



Performance Securing Declaration (Revised)

REPUBLIC OF THE PHILIPPINES)

CITY OF _____) S.S.

PERFORMANCE SECURING DECLARATION

Invitation to Bid: [Insert Reference Number indicated in the Bidding Documents] To: [Insert name and address of the Procuring Entity]

I/We, the undersigned, declare that:

1. I/We understand that, according to your conditions, to guarantee the faithful performance by the supplier/distributor/manufacture/contractor/consultant of its obligations under the Contract, I/we shall submit a Performance Securing Declaration within a maximum period of ten (10) calendar days from the receipt of the Notice of Award prior to the signing of the Contract.
2. I/We accept that: I/we will be automatically disqualified from bidding for any procurement contract with any procuring entity for a period of one (1) year for the first offense, or two (2) years **for the second offense**, upon receipt of your Blacklisting Order if I/We have violated my/our obligations under the Contract;
3. I/We understand that this Performance Securing Declaration shall cease to be valid upon:
 - a. issuance by the Procuring Entity of the Certificate of Final Acceptance, subject to the following conditions:
 - i. Procuring Entity has no claims filed against the contract awardee;
 - ii. It has no claims for labor and materials filed against the contractor; and
 - iii. Other terms of the contract; or
 - b. replacement by the winning bidder of the submitted PSD with a performance security in any of the prescribed forms under Section 39.2 of the 2016 revised IRR of RA No. 9184 as required by the end-user.

IN WITNESS WHEREOF, I/We have hereunto set my/our hand/s this ____ day of [month] [year] at [place of execution].

[Insert NAME OF BIDDER OR ITS

AUTHORIZED REPRESENTATIVE]

[Insert signatory's legal capacity]

Affiant

[Jurat]

[Format shall be based on the latest Rules on Notarial Practice]



FORM-06

STATEMENT OF ALL ITS ON-GOING GOVERNMENT AND PRIVATE CONTRACTS, INCLUDING CONTRACTS AWARDED BUT NOT YET STARTED

NAME OF CONTRACT	DATE OF CONTRACT	CONTRACT DURATION	CONTACT PERSON, CONTACT NO., ADDRESS, AND EMAIL ADDRESS	KINDS OF GOODS	AMOUNT OF CONTRACT	VALUE OF OUTSTANDING CONTRACT



FORM-07

STATEMENT OF SINGLE LARGEST COMPLETED CONTRACT SIMILAR TO THE PROJECT TO BE BID EQUIVALENT TO AT LEAST 50% OF THE ABC WITH ATTACHED SUPPORTING DOCUMENTS (i.e. P.O/CONTRACTS)

NAME OF CONTRACT	KINDS OF GOODS	AMOUNT OF CONTRACT	CONTACT PERSON, CONTACT NO., ADDRESS, AND EMAIL ADDRESS



Formula in the Computation of NFCC

NAME OF PROJECT

NAME OF COMPANY

NFCC = 15 (Current Assets – Current Liabilities) – Value of All Outstanding Works under On-going Contracts including Awarded Contracts yet to be started)

YEAR	CURRENT ASSETS	CURRENT LIABILITIES
TOTAL		

Value of Outstanding Works under On-going Contracts:

CONTRACT DESCRIPTION	TOTAL CONTRACT AMOUNT AT AWARD	PERCENTAGE OF PLANNED AND ACTUAL ACCOMPLISHMENT	ESTIMATED COMPLETION TIME
TOTAL			

Use additional sheet/s, if necessary

FORMULA:

$$15 \left(\frac{\text{Current Assets}}{\text{Current Assets}} - \frac{\text{Current Liabilities}}{\text{Current Liabilities}} \right) - \frac{\text{Total Outstanding Works}}{\text{Total Outstanding Works}} = \text{NFCC}$$

P _____ NFCC

Prepared and Submitted by:

Signature over Printed Name

(Name of Bank)

COMMITTED LINE OF CREDIT CERTIFICATE

Date: _____

Social Security System (SSS)
SSS Main Building, East Avenue
Diliman, Quezon City

CONTRACT PROJECT : _____
COMPANY/FIRM : _____
ADDRESS : _____
BANK/FINANCING : _____
INSTITUTION : _____
ADDRESS : _____
AMOUNT : _____

This is to certify that the above Bank/Financing Institution with business address indicated above, commits to provide the (Supplier/Distributor/Manufacturer/Contractor), if awarded the above-mentioned Contract, a credit line in the amount specified above which shall be exclusively used to finance the performance of the above-mentioned contract subject to our terms, conditions and requirements.

The credit line shall be available within fifteen (15) calendar days after receipt by the (Supplier/Distributor/Manufacturer/Contractor) of the Notice of Award and such line of credit shall be maintained until issuance of Certificate of Acceptance by the Social Security System.

This Certification is being issued in favor of said (Supplier/Distributor/Manufacturer/Contractor) in connection with the bidding requirement of (Name of Procuring Entity) for the above-mentioned Contract. We are aware that any false statements issued by us make us liable for perjury.

The committed line of credit cannot be terminated or cancelled without the prior written approval of Social Security System.

Name and Signature of Authorized Financing Institution Office

Office Designation

Concurred by:

Name & Signature of (Supplier/Distributor/Manufacturer/Contractor) Authorized Representative

Official Designation

SUBSCRIBED AND SWORN TO BEFORE ME this _____ day of _____ at _____
Philippines, Affiant exhibited to me his/her competent Evidence of Identity (as defines by the 2004
Rules on Notarial Practice _____ issued on _____ at _____, Philippines.

NOTARY PUBLIC

Doc No. : _____
Page No. : _____
Book No. : _____
Series of : _____

(Note: The amount committed should be machine validated in the Certificate itself)



