



SOCIAL SECURITY SYSTEM

PHILIPPINE BIDDING DOCUMENTS

Sixth Edition

**Procurement of
INFRASTRUCTURE
PROJECTS**

Government of the Republic of the Philippines

**VARIOUS PROJECTS AT SSS-OWNED
PROPERTY AT URDANETA VILLAGE
(RE-ADVERTISEMENT)**

ITB-SSS-CIVIL-2022-003

JULY 2022

Emily M. Beltran
Chairperson, TWG

TABLE OF CONTENTS

Glossary of Terms, Abbreviations, and Acronyms.....	4
Section I. Invitation to Bid	6
Section II. Instructions to Bidders.....	9
1. Scope of Bid.....	10
2. Funding Information	10
3. Bidding Requirements.....	10
4. Corrupt, Fraudulent, Collusive, Coercive, and Obstructive Practices	10
5. Eligible Bidders.....	10
6. Origin of Associated Goods	11
7. Subcontracts	11
8. Pre-Bid Conference	11
9. Clarification and Amendment of Bidding Documents.....	11
10. Documents Comprising the Bid: Eligibility and Technical Components	11
11. Documents Comprising the Bid: Financial Component	12
12. Alternative Bids	12
13. Bid Prices	12
14. Bid and Payment Currencies.....	12
15. Bid Security.....	12
16. Sealing and Marking of Bids.....	12
17. Deadline for Submission of Bids	13
18. Opening and Preliminary Examination of Bids	13
19. Detailed Evaluation and Comparison of Bids.....	13
20. Post Qualification.....	13
21. Signing of the Contract	13
Section III. Bid Data Sheet.....	14
Section IV. General Conditions of Contract	17
1. Scope of Contract.....	18
2. Sectional Completion of Works	18
3. Possession of Site.....	18
4. The Contractor's Obligations.....	18
5. Performance Security	18
6. Site Investigation Reports	19
7. Warranty.....	19
8. Liability of the Contractor.....	19
9. Termination for Other Causes	19
10. Dayworks	19
11. Program of Work.....	19
12. Instructions, Inspections and Audits	19
13. Advance Payment.....	20
14. Progress Payments	20

15. Operating and Maintenance Manuals.....	20
Section V. Special Conditions of Contract.....	21
Section VI. Specifications	27
Section VII. Drawings.....	31
Section VIII. Bill of Quantities	34
Section IX. Checklist of Technical and Financial Documents.....	47

Glossary of Terms, Abbreviations, and Acronyms

ABC – Approved Budget for the Contract.

ARCC – Allowable Range of Contract Cost.

BAC – Bids and Awards Committee.

Bid – A signed offer or proposal to undertake a contract submitted by a bidder in response to and in consonance with the requirements of the bidding documents. Also referred to as *Proposal* and *Tender*. (2016 revised IRR, Section 5[c])

Bidder – Refers to a contractor, manufacturer, supplier, distributor and/or consultant who submits a bid in response to the requirements of the Bidding Documents. (2016 revised IRR, Section 5[d])

Bidding Documents – The documents issued by the Procuring Entity as the bases for bids, furnishing all information necessary for a prospective bidder to prepare a bid for the Goods, Infrastructure Projects, and/or Consulting Services required by the Procuring Entity. (2016 revised IRR, Section 5[e])

BIR – Bureau of Internal Revenue.

BSP – Bangko Sentral ng Pilipinas.

CDA – Cooperative Development Authority.

Consulting Services – Refer to services for Infrastructure Projects and other types of projects or activities of the GOP requiring adequate external technical and professional expertise that are beyond the capability and/or capacity of the GOP to undertake such as, but not limited to: (i) advisory and review services; (ii) pre-investment or feasibility studies; (iii) design; (iv) construction supervision; (v) management and related services; and (vi) other technical services or special studies. (2016 revised IRR, Section 5[i])

Contract – Refers to the agreement entered into between the Procuring Entity and the Supplier or Manufacturer or Distributor or Service Provider for procurement of Goods and Services; Contractor for Procurement of Infrastructure Projects; or Consultant or Consulting Firm for Procurement of Consulting Services; as the case may be, as recorded in the Contract Form signed by the parties, including all attachments and appendices thereto and all documents incorporated by reference therein.

Contractor – is a natural or juridical entity whose proposal was accepted by the Procuring Entity and to whom the Contract to execute the Work was awarded. Contractor as used in these Bidding Documents may likewise refer to a supplier, distributor, manufacturer, or consultant.

CPI – Consumer Price Index.

DOLE – Department of Labor and Employment.

DTI – Department of Trade and Industry.

Foreign-funded Procurement or Foreign-Assisted Project – Refers to procurement whose funding source is from a foreign government, foreign or international financing institution as specified in the Treaty or International or Executive Agreement. (2016 revised IRR, Section 5[b]).

GFI – Government Financial Institution.

GOCC – Government-owned and/or –controlled corporation.

Goods – Refer to all items, supplies, materials and general support services, except Consulting Services and Infrastructure Projects, which may be needed in the transaction of public businesses or in the pursuit of any government undertaking, project or activity, whether in the nature of equipment, furniture, stationery, materials for construction, or personal property of any kind, including non-personal or contractual services such as the repair and maintenance of equipment and furniture, as well as trucking, hauling, janitorial, security, and related or analogous services, as well as procurement of materials and supplies provided by the Procuring Entity for such services. The term “related” or “analogous services” shall include, but is not limited to, lease or purchase of office space, media advertisements, health maintenance services, and other services essential to the operation of the Procuring Entity. (2016 revised IRR, Section 5[r])

GOP – Government of the Philippines.

Infrastructure Projects – Include the construction, improvement, rehabilitation, demolition, repair, restoration or maintenance of roads and bridges, railways, airports, seaports, communication facilities, civil works components of information technology projects, irrigation, flood control and drainage, water supply, sanitation, sewerage and solid waste management systems, shore protection, energy/power and electrification facilities, national buildings, school buildings, hospital buildings, and other related construction projects of the government. Also referred to as *civil works or works*. (2016 revised IRR, Section 5[u])

LGUs – Local Government Units.

NFCC – Net Financial Contracting Capacity.

NGA – National Government Agency.

PCAB – Philippine Contractors Accreditation Board.

PhilGEPS - Philippine Government Electronic Procurement System.

Procurement Project – refers to a specific or identified procurement covering goods, infrastructure project or consulting services. A Procurement Project shall be described, detailed, and scheduled in the Project Procurement Management Plan prepared by the agency which shall be consolidated in the procuring entity's Annual Procurement Plan. (GPPB Circular No. 06-2019 dated 17 July 2019)

PSA – Philippine Statistics Authority.

SEC – Securities and Exchange Commission.

SLCC – Single Largest Completed Contract.

SSS – Social Security System.

Supplier – refers to a citizen, or any corporate body or commercial company duly organized and registered under the laws where it is established, habitually established in business and engaged in the manufacture or sale of the merchandise or performance of the general services covered by his bid. (Item 3.8 of GPPB Resolution No. 13-2019, dated 23 May 2019). Supplier as used in these Bidding Documents may likewise refer to a distributor, manufacturer, contractor, or consultant.

UN – United Nations.

Section I. Invitation to Bid



REPUBLIC OF THE PHILIPPINES
SOCIAL SECURITY SYSTEM

East Avenue, Diliman, Quezon City
Tel. Nos. (632)8709-7198*(632)8920-6446

E-mail: member_relations@sss.gov.ph*Website <http://www.sss.gov.ph>

Invitation to Bid
ITB-SSS-Civil-2022-003

**VARIOUS PROJECTS AT SSS-OWNED PROPERTY AT URDANETA VILLAGE
(RE-ADVERTISEMENT)**

Approved Budget for the Contract (ABC) & Source of Fund	Delivery/ Completion Period	Price of Bid Documents (non- refundable)	Schedule of Activities Date/Time	
			Pre-bid Conference	Deadline of submission and receipt of bids
Lot 1 -Repair of Casa Real Fence – ₱679,512.00 (Code PAP No. 2022-126)	Within Sixty (60) calendar days upon receipt of Notice to Proceed and Job Order	₱1,000.00	July 20, 2022, (Wednesday) 2:00pm	August 10, 2022, (Wednesday) 2:30pm
Lot 2 - Repair of Swimming Pool – ₱995,623.00 (Code PAP No. 2022-140)	Within Seventy- Five (75) calendar days upon receipt of Notice to Proceed and Job Order	₱1,000.00		
Lot 3 - Waterproofing of Roof Decks – ₱858,228.00 (Code PAP No. 2022-141)	Within Sixty (60) calendar days upon receipt of Notice to Proceed and Job Order	₱1,000.00		
2022 Approved Budget under Investment Income of the 2022 Annual Procurement Plan				

1. The **SOCIAL SECURITY SYSTEM (SSS)** now invites bids for the above Procurement Project. Completion of the Works is required within the following:
 - a. Lot 1 – sixty (60) calendar days
 - b. Lot 2 – seventy-five (75) calendar days
 - c. Lot 3 – sixty (60) calendar days.

Bidders should have completed within five (5) years prior to the date of submission and receipt of bids, a contract similar to the Projects. The description of an eligible bidder is contained in the Bidding Documents, particularly, in Section II (Instructions to Bidders).

2. Bids received in excess of the ABC shall be automatically rejected at Bid opening.
3. Bidding will be conducted through open competitive bidding procedures using non-discretionary “pass/fail” criterion as specified in the 2016 revised Implementing Rules and Regulations (IRR) of Republic Act (RA) No. 9184.
4. Interested bidders may obtain further information from SSS and inspect the Bidding Documents at the address in the last item of the ITB from Monday to Friday, 8:00 a.m. to 5:00 p.m.
5. A complete set of Bidding Documents may be acquired by interested Bidders starting **11 July 2022 up to the scheduled submission & opening of bids** from the address stated in the last item of the ITB and upon payment of the applicable fee for the Bidding Documents, in the amount specified above.

The mode of payment will be on a cash basis payable at the SSS Cash Department, SSS Main Bldg., Ground floor, upon accomplishment of SSS Form R-6. The Bidding Documents shall be received personally by the prospective Bidder or his authorized representative.

It may also be downloaded free of charge from the website of the Philippine Government Electronic Procurement System (PhilGEPS) and the website of the SSS, provided that Bidders shall pay the applicable fee for the Bidding Documents not later than the submission of their bids.

6. The SSS will hold a Pre-Bid Conference on the date and time specified above at the Bidding Room, 2nd Floor, SSS Main Bldg., East Avenue, Diliman, Quezon City which shall be open to prospective bidders, but attendance shall not be mandatory.

The Pre-Bid Conference will be conducted through online conference using Microsoft Teams. Kindly e-mail us on or before 19 July 2022, through e-mail address bac@sss.gov.ph, the following:

- a. Name of the representative and e-mail address; and
- b. Technical and administrative queries.

7. Bids must be duly received by the BAC Secretariat at the Bidding Room, 2nd Floor, SSS Main Building, East Avenue, Diliman, Quezon City on the deadline specified above. All Bids must be accompanied by a bid security in any of the acceptable forms and in the amount stated in the ITB Clause 14.

Bid opening shall be on the date and time specified above at the Bidding Room, 2nd Floor, SSS Main Building, East Avenue, Diliman, Quezon City. Bids will be opened in the presence of the Bidders' representatives who choose to attend at the address above. Late bids shall not be accepted.

8. References to the dates and times shall be based on Philippine Standard time. Should any of the above dates fall on a holiday, the deadline shall be extended to the same time on the immediately succeeding business day in Quezon City.
9. The SSS reserves the right to reject any and all bids, declare a failure of bidding, or not award the contract at any time prior to contract award in accordance with Sections 35.6 and 41 of the 2016 revised IRR of RA No. 9184, without thereby incurring any liability to the affected bidder or bidders.
10. The SSS assumes no obligation to compensate or indemnify parties for any expense or loss that they may incur as a result of their participation in the procurement process, nor does SSS BAC guarantees that an award will be made as a result of this invitation. Furthermore, the SSS reserves the right to waive any defects or formality in the responses to the eligibility requirements and to this invitation and reserves the right to accept the proposal most advantageous to the agency.

11. For further information, please refer to:

Bids & Awards Committee

The Secretariat

2nd Flr., SSS Main Bldg., East Ave., Diliman, Q.C.

Tel # (632) 8922-1070; 8709-7198 local 5492 & 6382

Email – bac@sss.gov.ph

12. Bidding documents may be downloaded from the PROCUREMENT tab at www.sss.gov.ph starting **11 July 2022**.

THE CHAIRPERSON
BIDS & AWARDS COMMITTEE

ref.: itb-sss-civil-2022-003-Various Projects at Urdaneta Village (readv)

Section II. Instructions to Bidders

1. Scope of Bid

The Procuring Entity, *Social Security System* wishes to receive Bids for the Various Projects at SSS-Owned Property at Urdaneta Village (Re-advertisement), with identification number ITB-SSS-Civil-2022-003.

The Procurement Project (referred to herein as “Project”) is for the construction of Works, as described in Section VI (Specifications).

2. Funding Information

2.1. The GOP through the source of funding as indicated below for *CY 2022* in the amount of:

Lot 1 - Repair of Casa Real Fence	- ₱679,512.00
Lot 2 - Repair of Swimming Pool	- ₱995,623.00
Lot 3 - Waterproofing of Roof Decks	- ₱858,228.00

2.2. The source of funding is: 2022 Approved Budget under Investment Income of FY 2022 Annual Procurement Plan.

Lot 1	(Code PAP 20 2-126)
Lot 2	(Code PAP 2022-140)
Lot 3	(Code PAP 2022-141)

3. Bidding Requirements

The Bidding for the Project shall be governed by all the provisions of RA No. 9184 and its 2016 revised IRR, including its Generic Procurement Manual and associated policies, rules and regulations as the primary source thereof, while the herein clauses shall serve as the secondary source thereof.

Any amendments made to the IRR and other GPPB issuances shall be applicable only to the ongoing posting, advertisement, or invitation to bid by the BAC through the issuance of a supplemental or bid bulletin.

The Bidder, by the act of submitting its Bid, shall be deemed to have inspected the site, determined the general characteristics of the contracted Works and the conditions for this Project, such as (a) the location and the nature of the work; (b) climatic conditions; (c) transportation facilities; (c) nature and condition of the terrain, geological conditions at the site communication facilities, requirements, location and availability of construction aggregates and other materials, labor, water, electric power and access roads; and (d) other factors that may affect the cost, duration and execution or implementation of the contract, project, or work and examine all instructions, forms, terms, and project requirements in the Bidding Documents.

4. Corrupt, Fraudulent, Collusive, Coercive, and Obstructive Practices

The Procuring Entity, as well as the Bidders and Contractors, shall observe the highest standard of ethics during the procurement and execution of the contract. They or through an agent shall not engage in corrupt, fraudulent, collusive, coercive, and obstructive practices defined under Annex “I” of the 2016 revised IRR of RA No. 9184 or other integrity violations in competing for the Project.

5. Eligible Bidders

5.1. Only Bids of Bidders found to be legally, technically, and financially capable will be evaluated.

- 5.2. The Bidder must have an experience of having completed a Single Largest Completed Contract (SLCC) that is similar to this Project, equivalent to at least fifty percent (50%) of the ABC adjusted, if necessary, by the Bidder to current prices using the PSA's CPI, except under conditions provided for in Section 23.4.2.4 of the 2016 revised IRR of RA No. 9184.

A contract is considered to be "similar" to the contract to be bid if it has the major categories of work stated in the **BDS**.

- 5.3. For Foreign-funded Procurement, the Procuring Entity and the foreign government/foreign or international financing institution may agree on another track record requirement, as specified in the Bidding Document prepared for this purpose.
- 5.4. The Bidders shall comply with the eligibility criteria under Section 23.4.2 of the 2016 IRR of RA No. 9184.

6. Origin of Associated Goods

There is no restriction on the origin of Goods other than those prohibited by a decision of the UN Security Council taken under Chapter VII of the Charter of the UN.

7. Subcontracts

- 7.1. The Procuring Entity has prescribed that: **Subcontracting is not allowed.**

8. Pre-Bid Conference

The Procuring Entity will hold a pre-bid conference for this Project on the specified date and time and either at its physical address **Bidding Room, 2nd Floor, SSS Main Building, East Avenue, Diliman, Quezon City** and/or through online conference using **Microsoft Teams** as indicated in paragraph 6 of the **IB**.

9. Clarification and Amendment of Bidding Documents

Prospective bidders may request for clarification on and/or interpretation of any part of the Bidding Documents. Such requests must be in writing and received by the Procuring Entity, either at its given address or through electronic mail indicated in the **IB**, at least ten (10) calendar days before the deadline set for the submission and receipt of Bids.

10. Documents Comprising the Bid: Eligibility and Technical Components

- 10.1. The first envelope shall contain the eligibility and technical documents of the Bid as specified in **Section IX. Checklist of Technical and Financial Documents**.
- 10.2. If the eligibility requirements or statements, the bids, and all other documents for submission to the BAC are in foreign language other than English, it must be accompanied by a translation in English, which shall be authenticated by the appropriate Philippine foreign service establishment, post, or the equivalent office having jurisdiction over the foreign bidder's affairs in the Philippines. For Contracting Parties to the Apostille Convention, only the translated documents shall be authenticated through an apostille pursuant to GPPB Resolution No. 13-2019 dated 23 May 2019. The English translation shall govern, for purposes of interpretation of the bid.
- 10.3. A valid PCAB License is required, and in case of joint ventures, a valid special PCAB License, and registration for the type and cost of the contract for this Project. Any additional type of Contractor license or permit shall be indicated in the **BDS**.

- 10.4. A List of Contractor's key personnel (e.g., Project Manager, Project Engineers, Materials Engineers, and Foremen) assigned to the contract to be bid, with their complete qualification and experience data shall be provided. These key personnel must meet the required minimum years of experience set in the **BDS**.
- 10.5. A List of Contractor's major equipment units, which are owned, leased, and/or under purchase agreements, supported by proof of ownership, certification of availability of equipment from the equipment lessor/vendor for the duration of the project, as the case may be, must meet the minimum requirements for the contract set in the **BDS**.

11. Documents Comprising the Bid: Financial Component

- 11.1. The second bid envelope shall contain the financial documents for the Bid as specified in **Section IX. Checklist of Technical and Financial Documents**.
- 11.2. Any bid exceeding the ABC indicated in paragraph 1 of the **IB** shall not be accepted.
- 11.3. For Foreign-funded procurement, a ceiling may be applied to bid prices provided the conditions are met under Section 31.2 of the 2016 revised IRR of RA No. 9184.

12. Alternative Bids

Bidders shall submit offers that comply with the requirements of the Bidding Documents, including the basic technical design as indicated in the drawings and specifications. Unless there is a value engineering clause in the **BDS**, alternative Bids shall not be accepted.

13. Bid Prices

All bid prices for the given scope of work in the Project as awarded shall be considered as fixed prices, and therefore not subject to price escalation during contract implementation, except under extraordinary circumstances as determined by the NEDA and approved by the GPPB pursuant to the revised Guidelines for Contract Price Escalation guidelines.

14. Bid and Payment Currencies

- 14.1. Bid prices may be quoted in the local currency or tradeable currency accepted by the BSP at the discretion of the Bidder. However, for purposes of bid evaluation, Bids denominated in foreign currencies shall be converted to Philippine currency based on the exchange rate as published in the BSP reference rate bulletin on the day of the bid opening.
- 14.2. Payment of the contract price shall be made in Philippine Pesos.

15. Bid Security

- 15.1. The Bidder shall submit a Bid Securing Declaration or any form of Bid Security in the amount indicated in the **BDS**, which shall be not less than the percentage of the ABC in accordance with the schedule in the **BDS**.
- 15.2. The Bid and bid security shall be valid until one hundred twenty (120) calendar days reckoned from the date of the submission and opening of bids. Any bid not accompanied by an acceptable bid security shall be rejected by the Procuring Entity as non-responsive.

16. Sealing and Marking of Bids

Each Bidder shall submit one copy of the first and second components of its Bid.

The Procuring Entity may request additional hard copies and/or electronic copies of the Bid. However, failure of the Bidders to comply with the said request shall not be a ground for disqualification.

If the Procuring Entity allows the submission of bids through online submission to the given website or any other electronic means, the Bidder shall submit an electronic copy of its Bid, which must be digitally signed. An electronic copy that cannot be opened or is corrupted shall be considered non-responsive and, thus, automatically disqualified.

17. Deadline for Submission of Bids

The Bidders shall submit on the specified date and time and either at its physical address or through online submission as indicated in paragraph 7 of the **IB**.

18. Opening and Preliminary Examination of Bids

18.1. The BAC shall open the Bids in public at the time, on the date, and at the place specified in paragraph 9 of the **IB**. The Bidders' representatives who are present shall sign a register evidencing their attendance. In case videoconferencing, webcasting or other similar technologies will be used, attendance of participants shall likewise be recorded by the BAC Secretariat.

In case the Bids cannot be opened as scheduled due to justifiable reasons, the rescheduling requirements under Section 29 of the 2016 revised IRR of RA No. 9184 shall prevail.

18.2. The preliminary examination of Bids shall be governed by Section 30 of the 2016 revised IRR of RA No. 9184.

19. Detailed Evaluation and Comparison of Bids

19.1. The Procuring Entity's BAC shall immediately conduct a detailed evaluation of all Bids rated "*passed*" using non-discretionary pass/fail criteria. The BAC shall consider the conditions in the evaluation of Bids under Section 32.2 of 2016 revised IRR of RA No. 9184.

19.2. If the Project allows partial bids, all Bids and combinations of Bids as indicated in the **BDS** shall be received by the same deadline and opened and evaluated simultaneously so as to determine the Bid or combination of Bids offering the lowest calculated cost to the Procuring Entity. Bid Security as required by **ITB** Clause 15 shall be submitted for each contract (lot) separately.

19.3. In all cases, the NFCC computation pursuant to Section 23.4.2.6 of the 2016 revised IRR of RA No. 9184 must be sufficient for the total of the ABCs for all the lots participated in by the prospective Bidder.

20. Post Qualification

Within a non-extendible period of five (5) calendar days from receipt by the Bidder of the notice from the BAC that it submitted the Lowest Calculated Bid, the Bidder shall submit its latest income and business tax returns filed and paid through the BIR Electronic Filing and Payment System (eFPS), and other appropriate licenses and permits required by law and stated in the **BDS**.

21. Signing of the Contract

The documents required in Section 37.2 of the 2016 revised IRR of RA No. 9184 shall form part of the Contract. Additional Contract documents are indicated in the **BDS**.

Section III. Bid Data Sheet

Bid Data Sheet

ITB Clause										
5.2	<p>For this purpose, contracts similar to the Projects refers to contracts which have the same major categories of work, which shall be comprised of:</p> <p>a) Lot 1 – civil-architectural works Lot 2 – civil-architectural and specialty works (swimming pool) Lot 3 – specialty works (waterproofing) as detailed in the Specifications and Bill of Quantities (BOQ) Form, and</p> <p>b) Completed within (5) five years prior to the submission and opening of bid</p>									
7.1	Subcontracting is not allowed.									
10.3	<p>PCAB License and Registration:</p> <p>License Category : Trade/E Size Range : Small A Classification : General Building</p> <p>The bidder shall have at least five (5) years of experience in construction/ renovation including specialty works, as indicated in the BOQ and Specifications.</p>									
10.4	<p>Per lot, the key personnel must meet the required minimum years of experience set below:</p> <table border="1" style="width: 100%; border-collapse: collapse; text-align: center;"> <thead> <tr> <th style="width: 40%;">Key Personnel</th> <th style="width: 20%;">Required no. of years of relevant work experience</th> <th style="width: 40%;">Field of Experience</th> </tr> </thead> <tbody> <tr> <td>Project Engineer/Architect</td> <td>3 years</td> <td>Construction / Renovation Works</td> </tr> <tr> <td>Foreman</td> <td>3 years</td> <td>Construction / Renovation Works</td> </tr> </tbody> </table> <p>Except for the Foreman, all key personnel should be PRC-registered engineers / architects in good standing.</p>	Key Personnel	Required no. of years of relevant work experience	Field of Experience	Project Engineer/Architect	3 years	Construction / Renovation Works	Foreman	3 years	Construction / Renovation Works
Key Personnel	Required no. of years of relevant work experience	Field of Experience								
Project Engineer/Architect	3 years	Construction / Renovation Works								
Foreman	3 years	Construction / Renovation Works								
10.5	<p>Major equipment required for the project are as follows:</p> <p>a) 1-bagger concrete mixer b) 1 unit delivery truck</p>									
12	No further instruction.									
15.1	<p>The bid security shall be in the form of a Bid Securing Declaration or any of the following forms and amounts:</p> <p>a. The amount of not less than <i>Php13,590.24 (2% of ABC) for lot 1, Php19,912.46(2% of ABC) for lot 2, Php17,164.56(2% of ABC) for lot 3</i>, if bid security is in cash, cashier's/manager's check, bank draft/guarantee or irrevocable letter of credit;</p> <p>b. The amount of not less than <i>Php33,975.60(5% of ABC) for lot 1, Php49,781.15 (5% of ABC) for lot 2, Php42,911.40 (5% of ABC) for lot 3</i>, if bid security is in Surety Bond.</p>									
19.2	Partial bid is not allowed. The infrastructure project is packaged into three (3) lots and the lots shall not be divided into sub-lots for the purpose of bidding, evaluation, and contract award.									

eh

20	<p>The Lowest Calculated Bidder shall submit the following:</p> <ol style="list-style-type: none"> 1. Registration certificate from Securities and Exchange Commission (SEC) for corporation including Articles of Incorporation and General Information Sheet (GIS), Department of Trade and Industry (DTI) for sole proprietorship, or Cooperative Development Authority (CDA) for cooperatives or its equivalent document 2. Mayor's or Business permit issued by the city or municipality where the principal place of business of the prospective bidder is located, or the equivalent document for Exclusive Economic Zones or Areas; 3. Tax clearance per E.O. No. 398, s. 2005, as finally reviewed and approved by the Bureau of Internal Revenue (BIR) 4. Latest Audited Financial Statements 5. Latest income tax return corresponding to the Audited Financial Statements submitted, filed electronically (EFPS); 6. Quarterly VAT (business tax returns) per Revenue Regulations 3-2005 for the last six (6) months prior to the submission and opening of bids filed electronically (EFPS);
21	<p>Construction schedule and S-curve, manpower schedule, construction methods, equipment utilization schedule, construction safety and health program approved by the Department of Labor and Employment</p>

Section IV. General Conditions of Contract

1. Scope of Contract

This Contract shall include all such items, although not specifically mentioned, that can be reasonably inferred as being required for its completion as if such items were expressly mentioned herein. All the provisions of RA No. 9184 and its 2016 revised IRR, including the Generic Procurement Manual, and associated issuances, constitute the primary source for the terms and conditions of the Contract, and thus, applicable in contract implementation. Herein clauses shall serve as the secondary source for the terms and conditions of the Contract.

This is without prejudice to Sections 74.1 and 74.2 of the 2016 revised IRR of RA No. 9184 allowing the GPPB to amend the IRR, which shall be applied to all procurement activities, the advertisement, posting, or invitation of which were issued after the effectivity of the said amendment.

2. Sectional Completion of Works

If sectional completion is specified in the **Special Conditions of Contract (SCC)**, references in the Conditions of Contract to the Works, the Completion Date, and the Intended Completion Date shall apply to any Section of the Works (other than references to the Completion Date and Intended Completion Date for the whole of the Works).

3. Possession of Site

3.1 The Procuring Entity shall give possession of all or parts of the Site to the Contractor based on the schedule of delivery indicated in the **SCC**, which corresponds to the execution of the Works. If the Contractor suffers delay or incurs cost from failure on the part of the Procuring Entity to give possession in accordance with the terms of this clause, the Procuring Entity's Representative shall give the Contractor a Contract Time Extension and certify such sum as fair to cover the cost incurred, which sum shall be paid by Procuring Entity.

3.2 If possession of a portion is not given by the above date, the Procuring Entity will be deemed to have delayed the start of the relevant activities. The resulting adjustments in contract time to address such delay may be addressed through contract extension provided under Annex "E" of the 2016 revised IRR of RA No. 9184.

4. The Contractor's Obligations

The Contractor shall employ the key personnel named in the Schedule of Key Personnel indicating their designation, in accordance with **ITB** Clause 10.3 and specified in the **BDS**, to carry out the supervision of the Works.

The Procuring Entity will approve any proposed replacement of key personnel only if their relevant qualifications and abilities are equal to or better than those of the personnel listed in the Schedule.

5. Performance Security

5.1. Within ten (10) calendar days from receipt of the Notice of Award from the Procuring Entity but in no case later than the signing of the contract by both parties, the successful Bidder shall furnish the performance security in any of the forms prescribed in Section 39 of the 2016 revised IRR.

5.2. The Contractor, by entering into the Contract with the Procuring Entity, acknowledges the right of the Procuring Entity to institute action pursuant to RA No. 3688 against any subcontractor be they an individual, firm, partnership, corporation, or association supplying the Contractor with labor, materials and/or equipment for the performance of this Contract.

6. Site Investigation Reports

The Contractor, in preparing the Bid, shall rely on any Site Investigation Reports referred to in the SCC supplemented by any information obtained by the Contractor.

7. Warranty

7.1. In case the Contractor fails to undertake the repair works under Section 62.2.2 of the 2016 revised IRR, the Procuring Entity shall forfeit its performance security, subject its property(ies) to attachment or garnishment proceedings, and perpetually disqualify it from participating in any public bidding. All payables of the GOP in his favor shall be offset to recover the costs.

7.2. The warranty against Structural Defects/Failures, except that occasioned-on force majeure, shall cover the period from the date of issuance of the Certificate of Final Acceptance by the Procuring Entity. Specific duration of the warranty is found in the SCC.

8. Liability of the Contractor

Subject to additional provisions, if any, set forth in the SCC, the Contractor's liability under this Contract shall be as provided by the laws of the Republic of the Philippines.

If the Contractor is a joint venture, all partners to the joint venture shall be jointly and severally liable to the Procuring Entity.

9. Termination for Other Causes

Contract termination shall be initiated in case it is determined *prima facie* by the Procuring Entity that the Contractor has engaged, before, or during the implementation of the contract, in unlawful deeds and behaviors relative to contract acquisition and implementation, such as, but not limited to corrupt, fraudulent, collusive, coercive, and obstructive practices as stated in ITB Clause 4.

10. Dayworks

Subject to the guidelines on Variation Order in Annex "E" of the 2016 revised IRR of RA No. 9184, and if applicable as indicated in the SCC, the Dayworks rates in the Contractor's Bid shall be used for small additional amounts of work only when the Procuring Entity's Representative has given written instructions in advance for additional work to be paid for in that way.

11. Program of Work

11.1. The Contractor shall submit to the Procuring Entity's Representative for approval the said Program of Work showing the general methods, arrangements, order, and timing for all the activities in the Works. The submissions of the Program of Work are indicated in the SCC.

11.2. The Contractor shall submit to the Procuring Entity's Representative for approval an updated Program of Work at intervals no longer than the period stated in the SCC. If the Contractor does not submit an updated Program of Work within this period, the Procuring Entity's Representative may withhold the amount stated in the SCC from the next payment certificate and continue to withhold this amount until the next payment after the date on which the overdue Program of Work has been submitted.

12. Instructions, Inspections and Audits

The Contractor shall permit the GOP or the Procuring Entity to inspect the Contractor's accounts and records relating to the performance of the Contractor and to have them audited by auditors of the GOP or the Procuring Entity, as may be required.

13. Advance Payment

The Procuring Entity shall, upon a written request of the Contractor which shall be submitted as a Contract document, make an advance payment to the Contractor in an amount not exceeding fifteen percent (15%) of the total contract price, to be made in lump sum, or at the most two installments according to a schedule specified in the **SCC**, subject to the requirements in Annex “E” of the 2016 revised IRR of RA No. 9184.

14. Progress Payments

The Contractor may submit a request for payment for Work accomplished. Such requests for payment shall be verified and certified by the Procuring Entity’s Representative/Project Engineer. Except as otherwise stipulated in the **SCC**, materials and equipment delivered on the site but not completely put in place shall not be included for payment.

15. Operating and Maintenance Manuals

- 15.1. If required, the Contractor will provide “as built” Drawings and/or operating and maintenance manuals as specified in the **SCC**.
- 15.2. If the Contractor does not provide the Drawings and/or manuals by the dates stated above, or they do not receive the Procuring Entity’s Representative’s approval, the Procuring Entity’s Representative may withhold the amount stated in the **SCC** from payments due to the Contractor.

Section V. Special Conditions of Contract

Special Conditions of Contract

GCC Clause	
2	No sectional completion date
3.1	<p>The Procuring Entity shall give possession of all parts of the Site to the Contractor for the duration of the Contract which shall commence upon receipt of the Notice to Proceed and Contract/Job Order.</p> <p>Lot 1 - Repair of Casa Real Fence - 60 calendar days Lot 2 - Repair of Swimming Pool - 75 calendar days Lot 3 - Waterproofing of Roof Decks - 60 calendar days</p>
6	Not applicable
7.2	Not applicable
8	<p>Liability of the Contractor</p> <ol style="list-style-type: none"> <p>CONFIDENTIALITY. Neither party shall, without the prior written consent of the other, disclose or make available to any person, make public, or use directly or indirectly, except for the performance and implementation of the works, any confidential information, acquired from an information holder in connection with the performance of this Contract, unless: (i) the information is known to the disclosing party, as evidenced by its written records, prior to obtaining the same from the information holder and is not otherwise subject to disclosure restrictions on the disclosing party, (ii) the information is disclosed to the disclosing party by a third party who did not receive the same, directly or indirectly, from an information holder, and who has no obligation of secrecy with respect thereto, or (iii) required to be disclosed by law.</p> <p>The obligation of confidentiality by both parties, as provided herein, shall survive the termination of the Agreement.</p> <p>MERGER AND CONSOLIDATION. In case of merger, consolidation or change of ownership of the CONTRACTOR with other company, it is the responsibility of the surviving company/consolidated company/acquiring entity to inform SSS of the change in corporate structure/ownership. Failure to do so shall translate in such company assuming all liabilities of the acquired/merged company under the Agreement.</p> <p>FORCE MAJEURE. SUPPLIER shall not be liable for forfeiture of its performance security, liquidated damages, or termination for default if and to the extent that CONTRACTOR's delay in performance or other failure to perform its obligations under this Agreement is the result of a force majeure.</p> <p>For purposes of this Agreement the terms "force majeure" and "fortuitous event" may be used interchangeably. In this regard, a fortuitous event or force majeure shall be interpreted to mean an event which CONTRACTOR could not have foreseen, or which though foreseen, was inevitable. It shall not include ordinary unfavorable weather conditions; and any other cause the effects of which could have been avoided with the exercise of reasonable diligence by CONTRACTOR. Such events may include, but not limited to, acts of SSS in its sovereign capacity, wars or revolutions, fires, floods, epidemics, quarantine restrictions, and freight embargoes.</p> <p>If a force majeure situation arises, CONTRACTOR shall promptly notify SSS in writing of such condition and the cause thereof. Unless otherwise directed by SSS in writing, CONTRACTOR shall continue to perform its obligations under this Agreement as far as is reasonably practical and shall seek all reasonable alternative means for performance not prevented by the force majeure.</p>

4. **NON-ASSIGNMENT.** CONTRACTOR shall not assign its rights or obligations under this Agreement, in whole or in part, except with SSS's prior written consent. CONTRACTOR shall not subcontract in whole or in part the PROJECT and deliverables subject of this Agreement without the written consent of SSS.

5. **WAIVER.** Failure by either party to insist upon the other strict performance of any of the terms and conditions hereof shall not be deemed a relinquishment or waiver of any subsequent breach or default of the terms and conditions hereof, which can only be deemed made if expressed in writing and signed by its duly authorized representative. No such waiver shall be construed as modification of any of the provisions of the Agreement or as a waiver of any past or future default or breach hereof, except as expressly stated in such waiver.

6. **CUMULATIVE REMEDIES.** Any and all remedies granted to the parties under the applicable laws and the Contract shall be deemed cumulative and may therefore, at the sole option and discretion, be availed of by the aggrieved party simultaneously, successively, or independently.

7. **NO EMPLOYER-EMPLOYEE RELATIONSHIP.** It is expressly and manifestly understood and agreed upon that the employees of CONTRACTOR assigned to perform the PROJECT are not employees of SSS. Neither is there an employer-employee relationship between SSS and CONTRACTOR.

The Agreement does not create an employer-employee relationship between SSS and the CONTRACTOR including its personnel; that the services rendered by the personnel assigned by CONTRACTOR to SSS in the performance of its obligation under the contract do not represent government service and will not be credited as such; that its personnel assigned to SSS are not entitled to benefits enjoyed by SSS' officials and employees such as Personal Economic Relief Allowance (PERA), Representation and Transportation Allowance (RATA), ACA, etc.; that these personnel are not related within the third degree of consanguinity or affinity to the contracting officer and appointing authority of SSS; that they have not been previously dismissed from the government service by reason of an administrative case; that they have not reached the compulsory retirement age of sixty-five (65); and that they possess the education, experience and skills required to perform the job. The CONTRACTOR hereby acknowledges that no authority has been given by SSS to hire any person as an employee of the latter. Any instruction given by SSS or any of its personnel to CONTRACTOR's employees are to be construed merely as a measure taken by the former to ensure and enhance the quality of project performed hereunder. The CONTRACTOR shall, at all times, exercise supervision and control over its employees in the performance of its obligations under the contract.

8. **PARTNERSHIP.** Nothing in the contract shall constitute a partnership between the parties. No party or its agents or employees shall be deemed to be the agent, employee or representative of any other party.

9. **COMPLIANCE WITH SS LAW.** CONTRACTOR shall report all its employees to SSS for coverage and their contributions, as well as, all amortizations for salary/education/calamity and other SSS loans shall be updated. Should CONTRACTOR fail to comply with its obligations under the provisions of the SS Law and Employees' Compensation Act, SSS shall have the authority to deduct any unpaid SS and EC contributions, salary, educational, emergency and/or calamity loan amortizations, employer's liability for damages, including interests and penalties from CONTRACTOR's receivables under this Agreement.

Further, prescription does not run against SSS for its failure to demand SS contributions or payments from CONTRACTOR. Moreover, CONTRACTOR shall forever hold in trust SS contributions or payments of its employees until the same is fully remitted to SSS.

10. COMPLIANCE WITH LABOR LAWS. CONTRACTOR, as employer of the personnel assigned to undertake the PROJECT, shall comply with all its obligations under existing laws and their implementing rules and regulations on the payment of minimum wage, overtime pay, and other labor-related benefits as well as remittances or payment of the appropriate amount or contributions/payment (SSS, EC, Pag-IBIG, PhilHealth and taxes) with concerned government agencies/offices.

It is agreed further, that prior to the release of any payment by SSS to SUPPLIER, its President or its duly authorized representative, shall submit a sworn statement that all monies due to all its employees assigned to the PROJECT as well as benefits by law and other related labor legislation have been paid by CONTRACTOR and that he/she assumed full responsibility thereof.

11. COMPLIANCE WITH TAX LAWS. CONTRACTOR shall, in compliance with tax laws, pay the applicable taxes in full and on time and shall regularly present to SSS within the duration of the Contract, tax clearance from the Bureau of Internal Revenue (BIR) as well as copy of its income and business tax returns duly stamped by the BIR and duly validated with the tax payments made thereon. Failure by CONTRACTOR to comply with the foregoing shall entitle SSS to suspend payment of the Contract Price.

As required under Executive Order (EO) 398, s. 2005, CONTRACTOR shall submit income and business tax returns duly stamped and received by the BIR, before entering and during the duration of this Agreement. CONTRACTOR, through its responsible officer, shall also certify under oath that it is free and clear of all tax liabilities to the government. CONTRACTOR shall pay taxes in full and on time and that failure to do so will entitle SSS to suspend or terminate this Agreement.

12. LIQUIDATED DAMAGES. If CONTRACTOR fails to satisfactorily deliver any or all of the Goods and/or to perform the Services within the period(s) specified in the PBD inclusive of duly granted time extensions if any, SSS shall, without prejudice to its other remedies under this Agreement and under the applicable law, deduct from the Contract Price, as liquidated damages, the applicable rate of one tenth (1/10) of one (1) percent of the cost of the unperformed portion for every day of delay until actual delivery or performance. Once the amount of liquidated damages reaches ten percent (10%), SSS may rescind or terminate this Agreement, without prejudice to other courses of action and remedies open to it.

13. HOLD FREE and HARMLESS. SUPPLIER agrees to defend, indemnify, and hold SSS free and harmless from any and all claims, damages, expenses, fines, penalties and/or liabilities of whatever nature and kind, whether in law or equity, that may arise by reason of the implementation of the Agreement. In addition,

CONTRACTOR agrees to indemnify SSS for any damage as a result of said implementation.

	<p>SUPPLIER hereby assumes full responsibility for any injury, including death, loss or damage which may be caused to SSS' employees or property or third person due to CONTRACTOR's employees' fault or negligence, and further binds itself to hold SSS free and harmless from any of such injury or damage. SSS shall not be responsible for any injury, loss or damage which CONTRACTOR or any of its employees may sustain in the performance of CONTRACTOR's obligations under this Agreement.</p> <p>14. SETTLEMENT OF DISPUTES. If any dispute or difference of any kind whatsoever shall arise between SSS and CONTRACTOR in connection with or arising out of this Agreement, the Parties shall make every effort to resolve amicably such dispute or difference by mutual consultation.</p> <p>If after thirty (30) days, the Parties have failed to resolve their dispute or difference by such mutual consultation, then either SSS or CONTRACTOR may give notice to the other Party of its intention to commence arbitration, in accordance with RA No. 876, otherwise known as the "Arbitration Law" and RA No. 9285, otherwise known as the "Alternative Dispute Resolution Act of 2004," in order to settle their disputes.</p> <p>No arbitration in respect of this matter may be commenced unless such notice is given.</p> <p>Notwithstanding any reference to arbitration herein, the Parties shall continue to perform their respective obligations under this Agreement unless they otherwise agree.</p> <p>15. VENUE OF ACTIONS. In the event court action is necessary in order to promote Arbitration, such action shall be filed only before the proper courts of Quezon City, to the exclusion of all other venues.</p> <p>16. GOVERNING LAW. The Agreement shall be governed by and interpreted according to the laws of the Republic of the Philippines.</p> <p>17. AMENDMENTS. This Agreement may be amended only in writing and executed by the parties or their duly authorized representatives.</p> <p>18. SEPARABILITY. If any one or more of the provisions contained in the contract or any document executed in connection herewith shall be invalid, illegal or unenforceable in any respect under any applicable law, then: (i) the validity, legality and enforceability of the remaining provisions contained herein or therein shall not in any way be affected or impaired and shall remain in full force and effect; and (ii) the invalid, illegal or unenforceable provision shall be replaced by the parties immediately with a term or provision that is valid, legal and enforceable and that comes closest to expressing the intention of such invalid illegal or unenforceable term of provision.</p> <p>19. BINDING EFFECT. The Agreement shall be binding upon the Parties hereto, their assignee/s and successor/s-in-interest.</p>
10	Dayworks are applicable at the rate shown in the Contractor's original Bid.
11.1	The Contractor shall submit the Program of Work to the Procuring Entity's Representative within five (5) calendar days after the conduct of pre-construction meeting.
11.2	<p>The period between Program of Work updates is seven (7) calendar days.</p> <p>The amount to be withheld for late submission of an updated Program of Work is ten percent (10%) of the cost of accomplishment of the progress billing, on top of applicable ten percent (10%) retention money.</p>

13	The amount of the advance payment is 15% of the total contract price to be deducted in a pro-rated basis every Progress Billing.								
14	<p>Progress payment may be made in three (3) billings and upon written request by the Contractor, following the matrix below:</p> <table border="1" data-bbox="375 379 1308 782"> <thead> <tr> <th data-bbox="375 379 688 459">PROGRESS PAYMENT</th> <th data-bbox="688 379 1308 459">BASIS OF PAYMENT</th> </tr> </thead> <tbody> <tr> <td data-bbox="375 459 688 526">1st Billing</td> <td data-bbox="688 459 1308 526">20% or more work accomplishment.</td> </tr> <tr> <td data-bbox="375 526 688 594">2nd Billing</td> <td data-bbox="688 526 1308 594">75% or more work accomplishment</td> </tr> <tr> <td data-bbox="375 594 688 782">3rd or Final Billing</td> <td data-bbox="688 594 1308 782">One hundred percent (100%) completion of the project and upon issuance of Certificate of Completion as certified by the Procuring Entity's Representative</td> </tr> </tbody> </table> <p>Materials and equipment delivered on the site but not completely put in place shall not be included for payment.</p>	PROGRESS PAYMENT	BASIS OF PAYMENT	1 st Billing	20% or more work accomplishment.	2 nd Billing	75% or more work accomplishment	3 rd or Final Billing	One hundred percent (100%) completion of the project and upon issuance of Certificate of Completion as certified by the Procuring Entity's Representative
PROGRESS PAYMENT	BASIS OF PAYMENT								
1 st Billing	20% or more work accomplishment.								
2 nd Billing	75% or more work accomplishment								
3 rd or Final Billing	One hundred percent (100%) completion of the project and upon issuance of Certificate of Completion as certified by the Procuring Entity's Representative								
15.1	The date by which “as built” drawings are required is within two (2) weeks after the completion of the project.								
15.2	The amount to be withheld for failing to produce “as built” drawings and/or operating and maintenance manuals by the date required is ten percent (10%) of the Contract Price.								

Section VI. Specifications

I. PROGRAM OF WORKS

A. GENERAL REQUIREMENTS

- a) Renovation Permits / Clearances, As-built plans
- b) Temporary Facilities and Board-up / Site Enclosure, Water and Electricity Consumption

B. WORKMANSHIP

The work throughout shall be executed in the best and most thorough manner under the direction of and to the satisfaction of the SSS Engineer or Representative who will interpret the meaning of the drawings and specifications and shall have the authority to reject any works and materials, which in their judgement, are not in full accordance therewith required phases of work shall be done by skilled and competent men who are engaged or specialized in the type of work specified.

C. SITE EXAMINATION

Prospective bidders are required to conduct site inspection to determine all incidental materials and activities that are necessary to be furnished and executed to complete the project. Examine the site premises and all conditions apparent and visible therein. Consider all such conditions that may affect work. Measure every existing work/structure at site. Verify all given dimensions and deviations in the plans/drawings and Bill of Quantities. It shall be understood that the work covers all exposed external surface regardless of measurements made.

D. PROTECTION OF WORK AND PROPERTY

The contractor shall ensure protection of existing structures, properties and other areas not affected by the work specified, including office furniture and equipment. Any damage incurred during the activity shall be restored/repared by the Contractor at their own expense, and it shall be done in a satisfactory and approved manner.

Place warning signs where work is being undertaken. Remove work materials damaged by failure to provide protection, and replace with new work materials at no cost to the Owner.

E. SUBMITTALS

The Contractor shall submit samples of finishes, furnished materials and equivalent materials for approval of SSS Implementing Unit prior to installation or application.

F. QUALITY OF MATERIALS

All replacement materials shall be new, free from defects, passed and conformed to International Standard and Philippine Standard set forth by Bureau of Product Standards - Department of Trade and Industry.

G. CLEANING

Leave premises clean, neat and orderly. Remove all stains, spots, blemishes, soil dirt from all finished work. Remove all excess materials, soil, used containers, tools, equipment and supplies out of the SSS premises during the progress of work and upon completion of work.

H. AS-BUILT PLAN AND ELECTRONIC FILE

Three (3) sets 20" x 30" blue print as-built plans duly signed and sealed by the Contractor's Civil Engineer or Architect for Civil and Architectural plans, Electrical Engineer for Electrical and Structured Cabling Plans.

The contractor shall likewise submit electronic file copy as-built plan using AutoCAD software on USB or CD.

II. SCOPE OF WORKS AND MATERIAL SPECIFICATIONS

The work contemplated under this contract shall consist of furnishing of all materials, labor, plant, tools and equipment, permits including the satisfactory performance of all work necessary for the complete execution of all the work as shown on the plans, specifications and other contract documents. The following are the scope of work:

1. REPAIR OF PERIMETER FENCE – LOT 1

1) **Site Preparation**

- a) Demolition of Existing Fence
- b) Excavation, Backfilling & Restoration of affected structures
- c) Trimming/Cutting of excess tree roots
- d) Hauling & Disposal of Debris & Waste materials

2) **Repair of Perimeter Fence**

- a) Repair of perimeter fence which include concreting, laying of concrete hollow blocks, painting and grill works.

PARTICULARS	DESCRIPTION	REMARKS
1. Civil /Architectural Works	- 150mm thk. Concrete Hollow Blocks, Non-load bearing blocks w/ class A mortar - Cement, Portland - Sand, Screened - Gravel, Crushed - Deformed Steel Reinforcing Bars, Grade 40 - Square Bars for Security Grills of Trees	-Submit samples for approval
2. Painting Works	- 1 coat concrete neutralizer - Masonry Putty - 1 coat Primer paint - 2 coat Semi-gloss Latex paint	- Davies, Boysen or Approved Equivalent

2. RENOVATION OF COMMON SWIMMING POOL – LOT 2

1) **Site Preparation**

- a) Dismantling of Existing Wall and Floor Tiles
- b) Waterproofing of the Swimming Pool
- c) Hauling & Disposal of Debris & Waste Materials

2) **Swimming Pool Rehabilitation Works**

- a) Rehabilitation of common swimming pool which include replacement of pool tiles, water piping system, pool equipment and accessories

PARTICULARS	DESCRIPTION	REMARKS
1. Architectural / Specialty Works	-20cm x 20cm Ceramic Tiles Color: Walls - "Agua Green", Walk pavement - "Altea Mocha", Floors - "Iceberg Blue", Water level - "Agua DK Blue" -Waterproofing Plugs, Cement Adhesive	-Mariwasa, Lepanto, Eurotilesor approved equivalent -ABC or approved equivalent -Submit samples for approval
2. Water piping system	-uPVC Blue Pipes sch, 40	-Neltex or approved equivalent
3. Pool Equipment & Accessories	-Filter Tank for 36 sq.ft. Hayward Max -Whisperflo 1hp pump and moter HP 3/4 KW ST Volts 115/230 RPN 3450 including accessories -Eye Ball Fitting Set (1x1/2) -Multi Variflo Valve (Flow Valve) -PVC Ball Valve 1x1/2 thru union -Vacuum Fitting -Hydro Static Valve including accessories -Main Drain Cover -Return Fittings -LED underwater pool light including power supply and accessories	Submit samples for approval

3. WATERPROOFING OF ROOFDECKS – LOT 3

1) **Site Preparation**

- a) Removal of existing worn-out waterproofing materials on the surface of roofdeck
- b) Hauling and Disposal of Debris & Waste Materials

2) **Waterproofing works**

- a) Waterproofing of roofdeck which include repair of cracks & joints, levelling & correction of slopes, application of liquid applied waterproofing materials

PARTICULARS	DESCRIPTION	REMARKS
1. Sealant for repair of cracks & joints	- medium modulus putty sealant	- Submit sample for approval
2. Concrete leveling & correction of slopes	- cementitious leveling mortar	- Submit sample for approval
3. Primer	- one (1) water-borne epoxy primer	- Submit sample for approval
4. Waterproofing Membrane	- two (2) coats liquid applied polyurethane waterproofing membrane	- Submit sample for approval
5. Top Coat	- two (2) coats pigmented, color and UV stable aliphatic polyurethane top coat	- Submit sample for approval

Materials and work deemed necessary to complete the project but not specifically mentioned in the Specifications, working drawings or in the other contract documents are inferred and shall be supplied, installed and rendered by the contractor without extra cost to the owner. Such material shall be of the highest quality available, installed and applied in workmanlike manner at prescribed or appropriate locations.

Section VII. Drawings

LOT 1 - PERIMETER FENCE

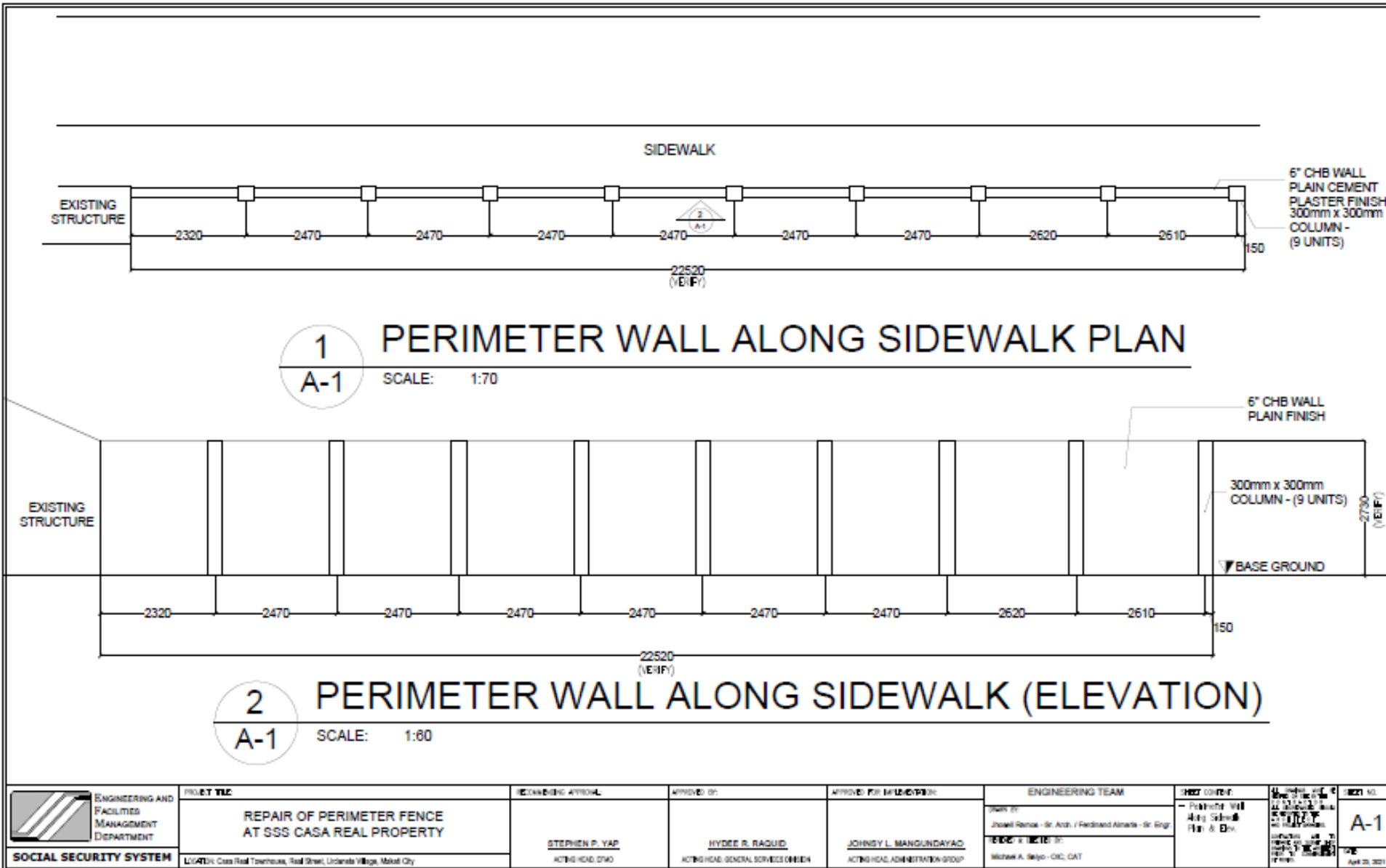

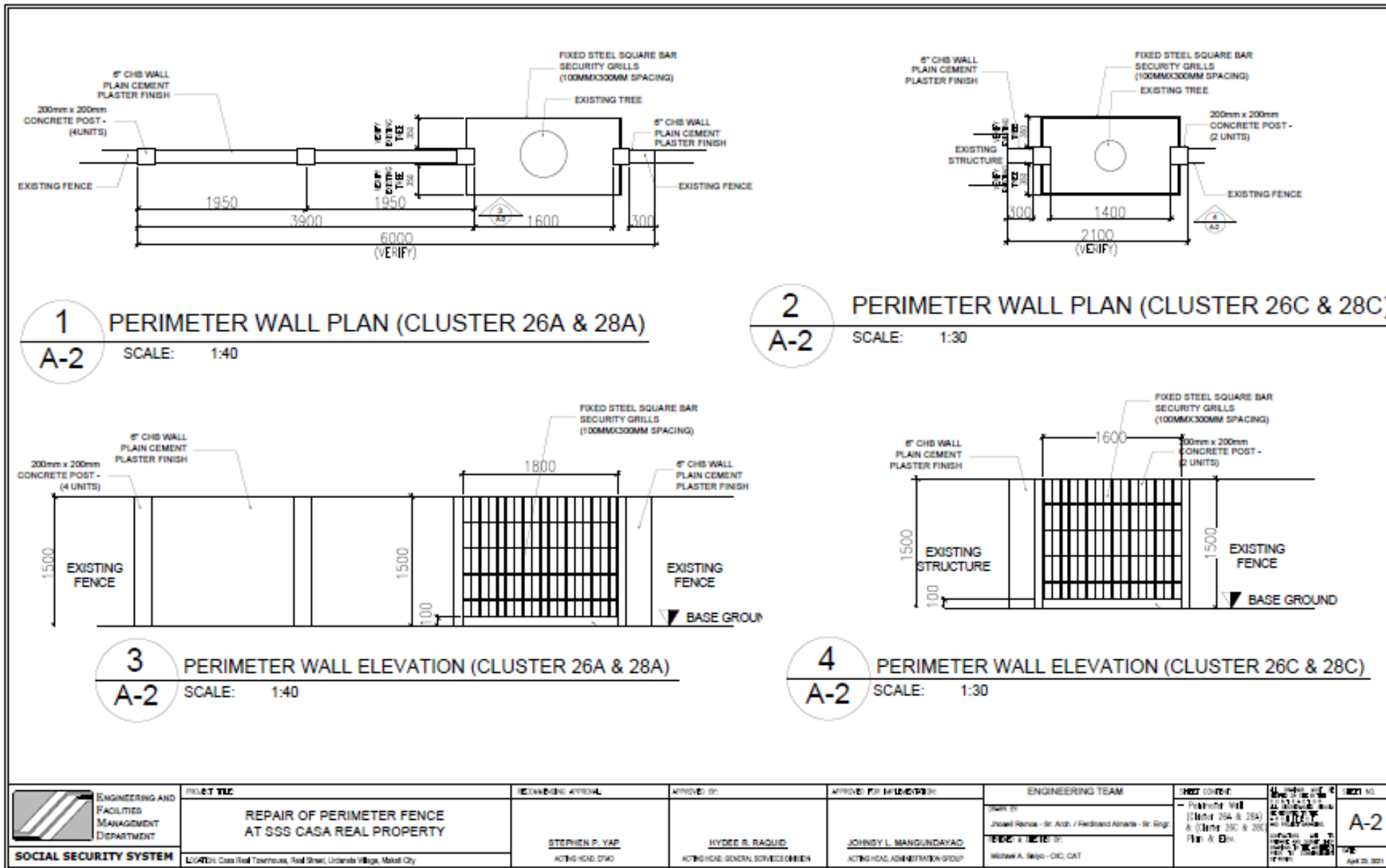

GENERAL CONSTRUCTION NOTES

GENERAL NOTES

1. IN THE INTERPRETATION OF THE DRAWING, INDICATED DIMENSION SHALL GOVERN AND DISTANCES AND SIZES SHALL NOT BE SCALED FOR CONSTRUCTION PURPOSES.
2. IN PREFERENCE TO OTHER DRAWINGS, SEE ARCHITECTURAL DRAWINGS FOR DEPRESSIONS IN FLOOR SLABS, OPENINGS IN THE WALLS AND SLABS, INTERIOR PARTITIONS, LOCATION OF DRAINS ETC.
3. IN CASE OF DISCREPANCIES AS TO LAYOUT, DIMENSIONS, AND ELEVATIONS BETWEEN THE STRUCTURAL PLANS, AND ARCHITECTURAL DRAWINGS, THE CONTRACTOR SHALL NOTIFY BOTH THE STRUCTURAL ENGINEER AND THE ARCHITECT.
4. ALL CONCRETE WORK SHALL BE DONE IN ACCORDANCE WITH THE ACI 318-95 BUILDING CODE REQUIREMENTS FOR REINFORCED CONCRETE AND ALL STRUCTURAL STEEL WORK ACCORDING TO AISC SPECIFICATION (9TH EDITION) IN SO FAR AS THEY DO NOT CONFLICT WITH THE LOCAL BUILDING CODE REQUIREMENT.
5. ACI REFERS TO AMERICAN CONCRETE INSTITUTE, AISC TO AMERICAN INSTITUTE OF STEEL CONSTRUCTION AND ASTM TO AMERICAN SOCIETY FOR TESTING MATERIALS.
6. CONSTRUCTION NOTES AND TYPICAL DETAILS APPLY TO ALL DRAWINGS UNLESS OTHERWISE SHOWN OR NOTED. MODIFY TYPICAL DETAILS AS DIRECTED TO MEET SPECIAL CONDITIONS.
7. SHOP DRAWINGS WITH ERECTION AND PLACING DIAGRAMS OF ALL STRUCTURAL STEELS, MISCELLANEOUS IRON, PRE-CAST CONCRETE, ETC. SHALL BE SUBMITTED FOR ENGINEERS APPROVAL BEFORE FABRICATION.
8. CONTRACTOR SHALL NOTE AND PROVIDE ALL MISCELLANEOUS CURBS, SILLS, STROOLS, EQUIPMENTS AND MECHANICAL BASINS THAT ARE REQUIRED BY THE ARCHITECTURAL, ELECTRICAL AND MECHANICAL DRAWINGS.
9. ALL RESULTS OF MATERIAL TESTING FOR CONCRETE, REINFORCING BARS, & STRUCTURAL STEEL MUST BE NOTED & APPROVED BY THE STRUCTURAL ENGINEER.

NOTES ON REINFORCEMENTS

1. UNLESS OTHERWISE NOTED IN PLANS, THE YIELD STRENGTH OF THE REINFORCING BARS SHALL BE:
 - A. FOOTINGS, FOOTING BEAMS AND ORDERS $f_y = 275 \text{ MPa (40,000 psi)}$
 - B. COLUMNS AND SHEAR WALLS $f_y = 275 \text{ MPa (40,000 psi)}$
 - C. BEAMS AND ORDERS $f_y = 275 \text{ MPa (40,000 psi)}$
 - D. NON-LOAD BEARING WALL PARTITIONS, HEBBED SLABS, FLOOR & ROOF SLABS, PARAPETS, CATCH BASIN, SIDE WALK $f_y = 227.5 \text{ MPa (33,000 psi)}$
2. ALL REINFORCING BAR SIZE 10MM OR LARGER SHALL BE DEFORMED IN ACCORDANCE WITH ASTM A 706. BARS SMALLER THAN 10MM MAY BE FLAT.
3. SPLICES SHALL BE SECURELY WIRED TOGETHER AND SHALL BE STAGGERED WHEREVER POSSIBLE.

NOTES ON COLUMNS

1. PROVIDE EXTRA SETS OF TIES AT 100mm O.C. FOR TIED COLUMN AND REINFORCEMENT ABOVE AND BELOW BEAM COLUMN CONNECTIONS FOR A DISTANCE FROM FACE OF CONNECTION EQUAL TO THE GREATER OF THE OVERALL THICKNESS OF COLUMN, $\frac{1}{4}$ THE CLEAR HEIGHT OF COLUMN OR 450mm.
2. COLUMN TIES SHALL BE PROTECTED EVERYWHERE BY A COVERING CONCRETE CAST MONOLITHICALLY WITH THE CORE WITH THE MINIMUM THICKNESS OF 40mm AND NOT LESS THAN 40 TIMES THE MAXIMUM SIZE OF COARSE AGGREGATE IN MILLIMETERS.
3. UNLESS OTHERWISE IN THE PLANS, LAP SPLICES FOR VERTICAL COLUMN REINFORCEMENT SHALL BE MADE WITHIN THE CENTER HALF OF COLUMN HEIGHT, AND THE SPLICE LENGTH SHALL NOT BE LESS THAN 40 BAR DIAMETERS. WELDING OR APPROVED MECHANICAL DEVICES MAY BE USED PROVIDED THAT NOT MORE THAN ALTERNATE BARS ARE WELDED OR MECHANICALLY SPLICED AT ANY LEVEL AND THE VERTICAL DISTANCES BETWEEN THESE WELDS OR SPLICES OF ADJACENT BARS IS NOT LESS THAN 600mm.

NOTES ON BEAMS AND GIRDERS

1. IF THE BEAM REINFORCING BARS END IN A WALL THE CLEAR DISTANCE FROM THE BAR TO THE FURTHER FACE OF THE WALL NOT BE LESS THAN 25mm. TOP BAR SHALL NOT BE SPLICED WITHIN THE COLUMN OR WITHIN A DISTANCE TWICE THE MEMBER DEPTH FROM THE FACE OF THE COLUMN. AT LEAST TWO STIRRUPS SHALL BE PROVIDED AT ALL SPLICES.
2. WHEN A BEAM CROSSES A GIRDER, REST BEAM ON TOP OF GIRDER BARS, BEAM REINFORCING BAR SHALL SYMMETRICAL ABOUT CENTER LINE WHENEVER POSSIBLE.
3. GENERALLY NO SPLICES SHALL BE PERMITTED AT POINTS WHERE CRITICAL BENDING STRESSES OCCUR. WELDED SPLICES SHALL DEVELOP IN TENSION AT LEAST 125 % OF THE SPECIFIED YIELD STRENGTH OF THE BAR NOT MORE THAN 50 % OF THE BARS AT ANY ONE SECTION IS ALLOWED TO BE SPLICED THEREIN.

NOTES ON FOOTING

1. FOOTING ARE DESIGNED BASED ON SITE ALLOWABLE BEARING CAPACITY.
2. FOOTING SHALL REST AT LEAST 1200mm BELOW NATURAL GRADE LINE UNLESS OTHERWISE INDICATED IN PLANS. NO FOOTING SHALL REST ON FILL.
3. MINIMUM CONCRETE PROTECTION FOR REINFORCEMENTS SHALL BE 75mm CLEAR FOR CONCRETE DEPOSITED THE GROUND AND 50mm FOR CONCRETE DEPOSITED AGAINST A FORMWORK.

NOTES ON CONCRETE MIXES & PLACING

1. ALL CONCRETE SHALL DEVELOP A MIN. COMPRESSIVE STRENGTH AT THE END OF TWENTY EIGHT (28) DAYS WITH CORRESPONDING MINIMUM SIZES AGGREGATE & SLUMPS AS FOLLOWS.
- | LOCATION | 28 DAYS STRENGTH | MAX. SIZES OF AGGREGATE | MAX. SLUMP |
|--|---------------------|-------------------------|------------|
| ALL OTHERS, INCLUDING SUSPENDED SLABS, | 4000 PSI (27.6 MPa) | 20mm | 100mm |
| COLUMN | 4000 PSI (27.6 MPa) | 20mm | 100mm |
| BEAMS, SLABS | 4000 PSI (27.6 MPa) | 20mm | 100mm |
| SLAB ON FILL | 3000 PSI (20.7 MPa) | 20mm | 100mm |

2. MAINTAIN A MINIMUM CONCRETE COVER FOR REINFORCING STEEL AS FOLLOWS.

SUSPENDED SLABS	20mm
SLAB ON GRADE	40mm
WALLS ABOVE GRADE	25mm
BEAM STIRRUPS AND COLUMN TIES	40mm
WHERE TO CONCRETE IS EXPOSED TO EARTH BUT POURED AGAINST FORMS WHERE CONCRETE IS DEPOSITED DIRECTLY AGAINST EARTH	50mm
	75mm
3. CONCRETE SHALL BE DEPOSITED IN ITS FINAL POSITION WITHOUT SEGREGATION. RE-HANDLING OR PLACING SHALL BE DONE PREFERABLY WITH BUCKETS, BUCKETS OR WHEELBARROWS, NO CHUTES WILL BE ALLOWED EXCEPT TO TRANSFER CONCRETE FROM HOPPERS TO BUCKETS, WHEELBARROWS OR BUCKETS IN WHICH CASE THEY SHALL NOT EXCEED SIX (6) METERS IN AGGREGATE LENGTH.
4. NO DEPOSITING OF CONCRETE SHALL BE ALLOWED WITHOUT THE USE OF VIBRATORS UNLESS AUTHORIZED IN WRITING BY THE DESIGNERS AND ONLY FOR UNUSUAL CONDITION WHERE VIBRATORS WERE EXTREMELY DIFFICULT TO ACCOMPLISH.
5. ALL ANCHOR BOLTS, DOWELS AND OTHER INSERTS, SHALL BE PROPERLY POSITIONED & SECURED IN PLACE PRIOR TO PLACING OF CONCRETE.
6. ALL CONCRETE SHALL BE KEPT MOIST FOR A MINIMUM OF SEVEN CONSECUTIVE DAYS IMMEDIATELY AFTER POURING BY THE USE OF WET BURLAP, FOG SPRAYING, CURING COMPOUNDS OR OTHER APPROVED METHODS.
7. STRIPPING OF FORMS AND SHORES:

FOUNDATION	24 HRS
SUSPENDED SLAB EXCEPT WHEN ADDITIONAL LOADS ARE IMPOSED	8 DAYS
WALLS	21 DAYS
BEAMS	14 DAYS
COLUMNS	21 DAYS
8. THE CONTRACTOR SHALL FURNISH AND MAINTAIN ADEQUATE FORMS AND SHORING UNTIL THE CONCRETE MEMBERS HAVE ATTAINED THEIR WORKING CONDITION AND STRENGTH.

NOTES ON CONCRETE HOLLOW BLOCK WALLS

1. UNLESS OTHERWISE SHOWN IN PLANS ALL CONCRETE HOLLOW BLOCKS AND CERAMIC BLOCKS SHALL BE REINFORCED AS SHOWN IN THE SCHEDULE OF CONCRETE HOLLOW BLOCKS AND CERAMIC BLOCK REINFORCEMENT.

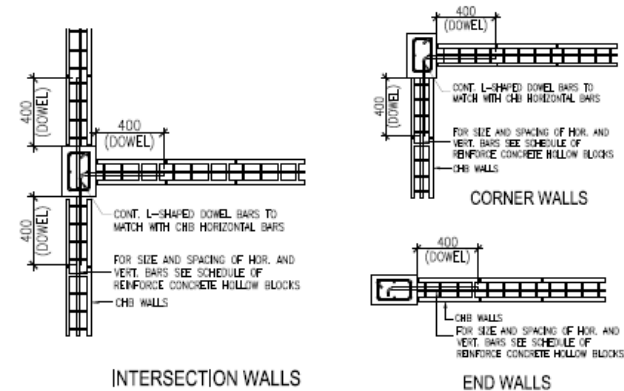

SCHEDULE OF CONCRETE HOLLOW BLOCK AND CERAMIC BLOCK REINFORCEMENT

BLOCK THICKNESS	STEEL REINFORCEMENTS		NOTES
	HORIZONTAL	VERTICAL	
100 mm	10mm ϕ @ 600mm O.C.	12mm ϕ @ 600mm O.C.	A. MINIMUM LAPS SPICE = 0.25m B. PROVIDE RIGHT ANGLE REINFORCEMENT AT CORNERS 0.92m LONG
150 mm	10mm ϕ @ 600mm O.C.	12mm ϕ @ 600mm O.C.	C. WHERE CHB OR CER. BLK. WALL DOWELS JOIN COL. R.C. BEAMS AND WALL DOWELS WITH THE SAME SIZE AS VERT. OR HOR. REINFORCEMENTS SHALL BE PROVIDED
200 mm	10mm ϕ @ 600mm O.C.	12mm ϕ @ 600mm O.C.	

NOTES ON WELDS

1. WELDING ELECTRODES SHALL CONFORM TO AWS A-5.1 OR 5.5; E70 ELECTRODES.
2. WELDS SHALL DEVELOP THE FULL STRENGTH OF MEMBERS JOINED UNLESS OTHERWISE SHOWN OR DETAILED IN THE DRAWINGS.

NOTES ON STRUCTURAL STEEL

1. STRUCTURAL STEEL TO BE USED FOR FABRICATION AND ERECTION OF THIS STRUCTURE SHALL COMPLY WITH ALL THE PROVISION OF AISC SPECIFICATION FOR THE DESIGN, FABRICATION AND ERECTION OF STRUCTURAL STEEL FOR BUILDING LATEST EDITION OTHERWISE INDICATED.
2. ALL WELDED CONNECTIONS SHALL DEVELOP THE FULL STRENGTH OF THE MEMBERS CONNECTED.

	PROJECT TITLE	RECOMMENDING APPROVAL	APPROVED BY:	APPROVED FOR IMPLEMENTATION:	ENGINEERING TEAM	SHEET CONTENT	ALL DRAWINGS MUST BE FORWARDED TO THE SOCIAL SECURITY SYSTEM FOR REVIEW AND APPROVAL. ALL REVISIONS MUST BE APPROVED BY THE SOCIAL SECURITY SYSTEM AND PROJECT MANAGER. CONTRACTOR HAS TO FURNISH HIS OWN SHOP DRAWINGS TO THE ARCHITECT FOR REVIEW AND APPROVAL (IF ANY).	SHEET NO. S-1 DATE April 23, 2021
	REPAIR OF PERIMETER FENCE AT SSS CASA REAL PROPERTY LOCATION: Casa Real Townhouse, Real Street, Urdaneta Village, Meralco City	STEPHEN P. YAP ACTING HEAD, E/MO	HYDEE R. RAQUID ACTING HEAD, GENERAL SERVICES DIVISION	JOHNSY L. MANGUNDAYAO ACTING HEAD, ADMINISTRATION GROUP	DRAWN BY: Jhosell Ramos - Sr. Arch. / Ferdinand Almaria - Sr. Engr. REVIEWED & CHECKED BY: Michael A. Salyo - ChC, CAT	- General Construction Notes		

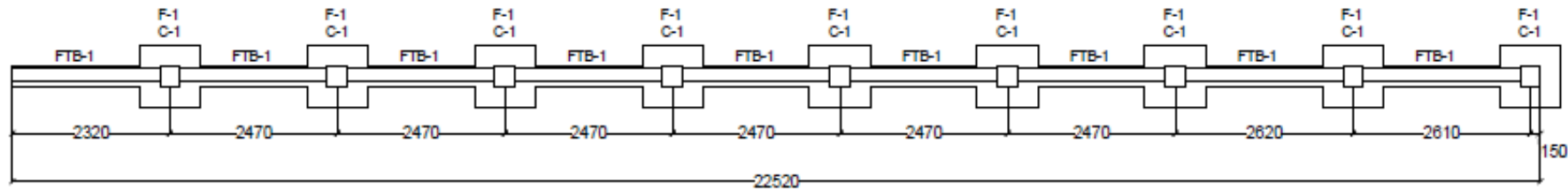

1 FOUNDATION PLAN (PERIMETER WALL ALONG SIDEWALK)
S-2 SCALE: 1:80

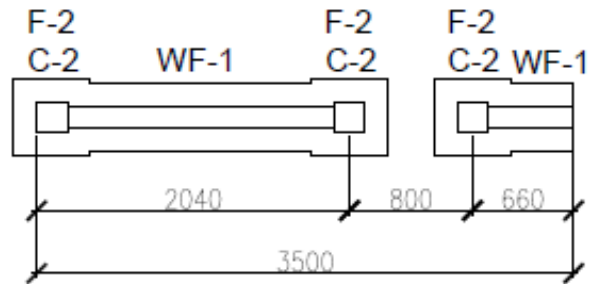

2 FOUNDATION PLAN (CLUSTER 26A & 28A)
S-2 SCALE: 1:30

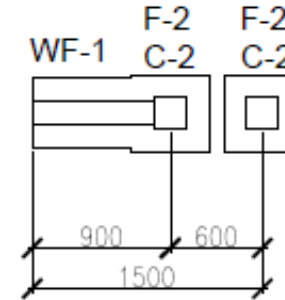

3 FOUNDATION PLAN (CLUSTER 26C & 28C)
S-2 SCALE: 1:30

 ENGINEERING AND FACILITIES MANAGEMENT DEPARTMENT SOCIAL SECURITY SYSTEM	PROJECT TITLE REPAIR OF PERIMETER FENCE AT SSS CASA REAL PROPERTY	RECOMMENDING APPROVAL STERNEN P. YAP ACTING HEAD, DFM	APPROVED BY HYDEE R. RAQUID ACTING HEAD, GENERAL SERVICES DIVISION	APPROVED FOR IMPLEMENTATION JOHNSY L. MANGUNDAYAO ACTING HEAD, ADMINISTRATION GROUP	ENGINEERING TEAM Drawn by: Jhoell Renee - Sr. Arch. / Ferdinand Almaria - Sr. Eng. Checked by: MICHELLE B. BAYAN MICHELLE A. SAYSO - OIC, CAT	REVISIONS - Foundation Plan	PROJECT NO. S-2 DATE April 25, 2021
	Location: Casa Real Townhouse, Real Street, Urdaneta Village, Malab City						

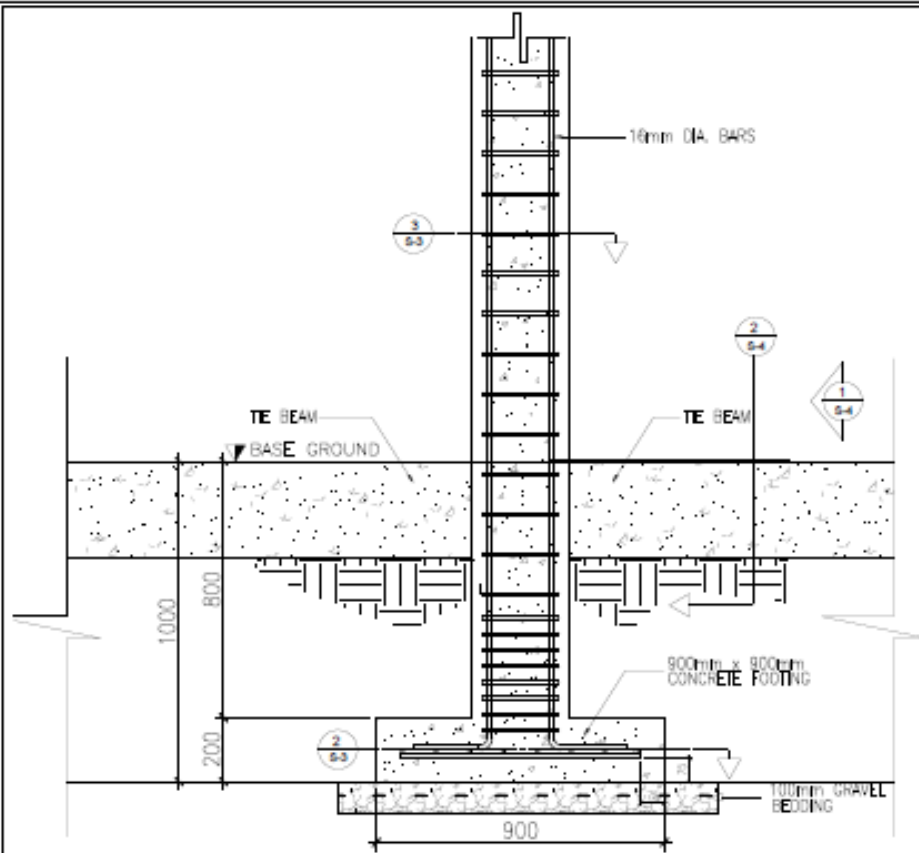



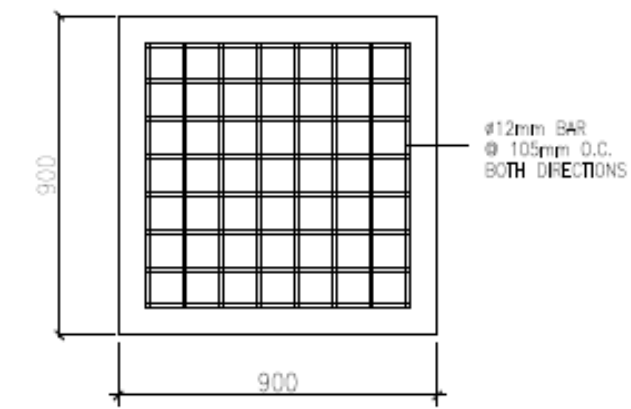

1 FOUNDATION DETAILS
S-3 SCALE: NTS

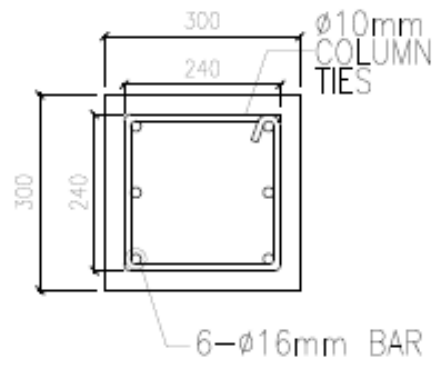

2 FOOTING DETAILS
S-3 SCALE: NTS



3 COLUMN DETAILS
S-3 SCALE: NTS

 ENGINEERING AND FACILITIES MANAGEMENT DEPARTMENT SOCIAL SECURITY SYSTEM	PROJECT TITLE REPAIR OF PERIMETER FENCE AT SSS CASA REAL PROPERTY	ENGINEERING APPROVAL STEPHEN P. YAP <small>ACTING HEAD, DMO</small>	APPROVED BY HYDEE R. RAQUID <small>ACTING HEAD, GENERAL SERVICES DIVISION</small>	APPROVED FOR IMPLEMENTATION JOHNSY L. MANGUNDAYAO <small>ACTING HEAD, ADMINISTRATION GROUP</small>	ENGINEERING TEAM DESIGN BY: Jovell Ramos - Sr. Arch. / Ferdinand Almaraz - Sr. Engr. CHECKED BY: Michael A. Salayo - CIV. ENGR.	PROJECT CONTROL - Prepared by:  - Checked by:  - Approved by: 	PROJECT NO. S-3 DATE April 23, 2021
	<small>Location: Casa Real Townhouse, Real Street, Urdaneta Village, Malab City</small>						

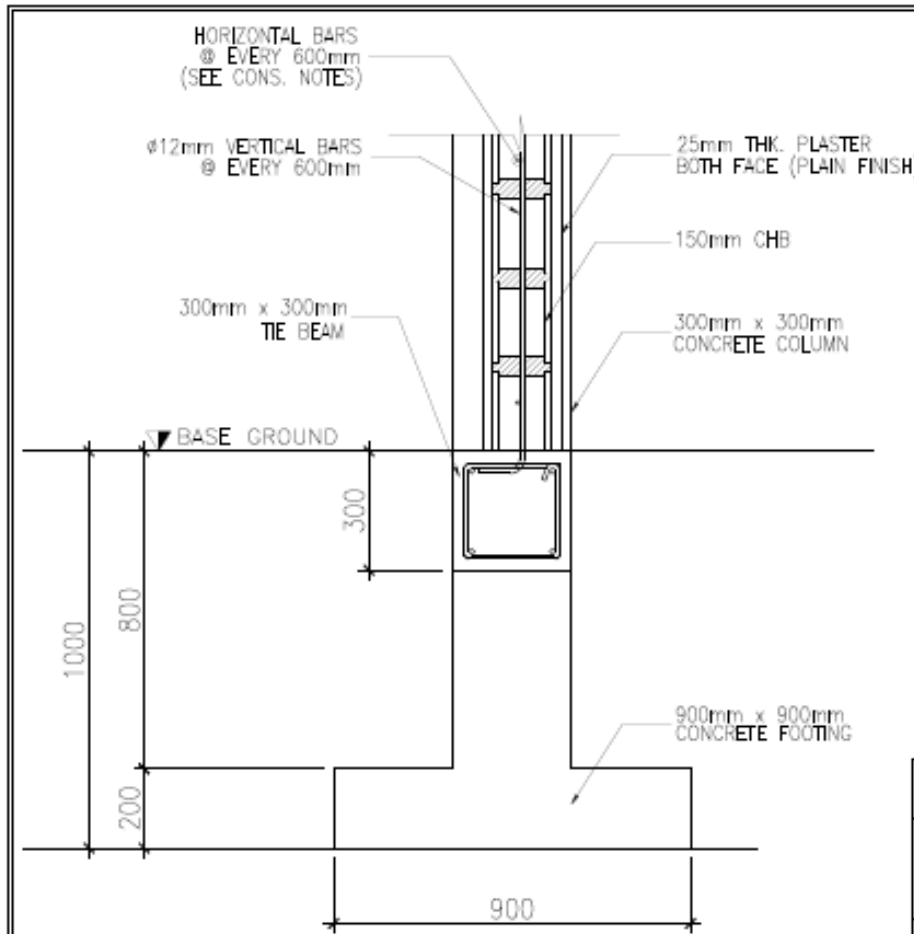

1 TIE BEAM DETAILS
S-4 SCALE: NTS

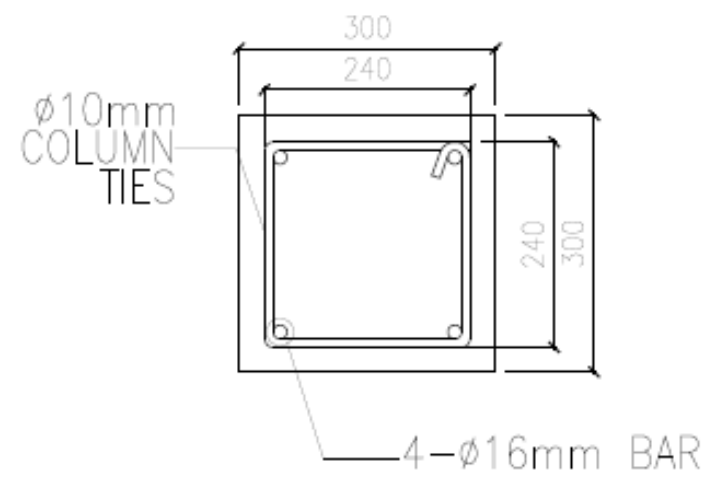

2 TIE BEAM (SECTION)
S-4 SCALE: NTS

BEAM SCHEDULE											
BEAM MARK	BEAM DIMENSIONS (mm)		STEEL REINFORCEMENT						STIRRUPS #10mm (UNLESS NOTED OTHERWISE)	REMARKS	
			LEFT		MID SPAN		RIGHT				
	b	h	REBAR (#mm)	TOP	BOT.	TOP	BOT.	TOP	BOT.		
FTB-1	300	300	#16mm	2	2	2	2	2	2	1@50, 6@100, REST@200	REINFORCED CONCRETE (RC)

ENGINEERING AND FACILITIES MANAGEMENT DEPARTMENT SOCIAL SECURITY SYSTEM	PROJECT TITLE REPAIR OF PERIMETER FENCE AT SSS CASA REAL PROPERTY	REVISIONS APPROVAL STERVEN P. YAP ACTING HEAD DMO	APPROVED BY HYDEE R. RAQUID ACTING HEAD GENERAL SERVICES DIVISION	APPROVED FOR EXECUTION BY JOHNEY L. MANGUNDAYAG ACTING HEAD ADMINISTRATION GROUP	ENGINEERING TEAM DRAWN BY: Jhosell Romulo - Sr. Arch. / Ferdinand Almado - Sr. Eng. CHECKED BY: Wendee A. Salgo - OIC, CAT	SHEET CONTENT - Perimeter Wall - Alloy Steel - Detail - Beam Schedule	SHEET NO. S-4 DATE April 25, 2021
	LOCATION: Casa Real Townhouse, Real Street, Urdaneta Village, Marikina City						

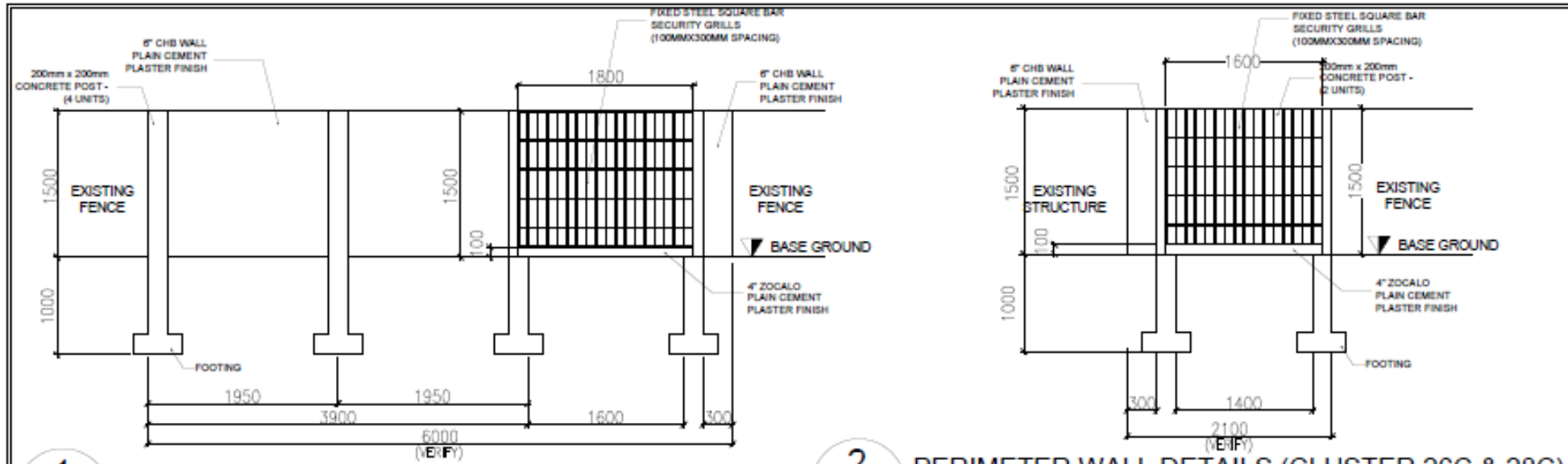

1 PERIMETER WALL DETAILS (CLUSTER 26A & 28A)
S-5 SCALE: NTS

2 PERIMETER WALL DETAILS (CLUSTER 26C & 28C)
S-5 SCALE: NTS

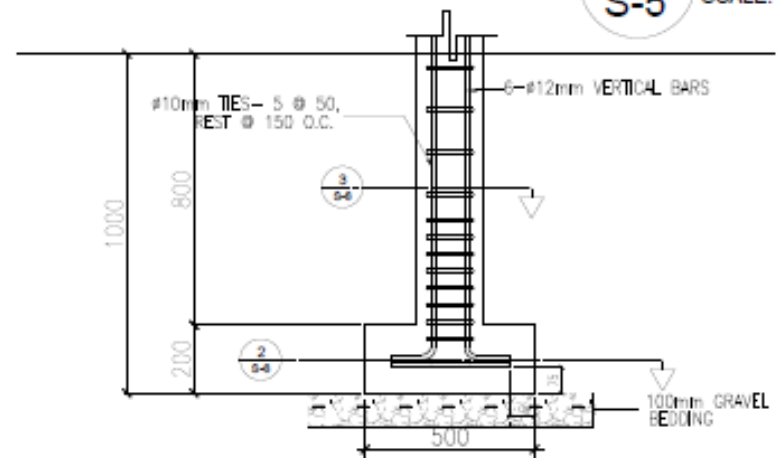

3 FOUNDATION DETAILS
S-5 SCALE: NTS

<p>ENGINEERING AND FACILITIES MANAGEMENT DEPARTMENT</p> <p>SOCIAL SECURITY SYSTEM</p>	<p>PROJECT TITLE:</p> <p>REPAIR OF PERIMETER FENCE AT SSS CASA REAL PROPERTY</p>	<p>ENGINEERING APPROVAL:</p> <p>STEPHEN P. YAP ACTING CHIEF CIVIL</p>	<p>APPROVED BY:</p> <p>HYDEE R. RAQUID ACTING HEAD GENERAL SERVICES DIVISION</p>	<p>APPROVED FOR BUILDING PERMITS:</p> <p>JOHNSY L. MANGUNDAYAD ACTING HEAD ADMINISTRATION GROUP</p>	<p>ENGINEERING TEAM:</p> <p>Drawn by: Jhovell Ramos - Sr. Arch. / Ferdinand Almada - Sr. Eng.</p> <p>Checked by: Michael A. Salpo - Chd. CAT</p>	<p>HEET CONTENT:</p> <p>- Perimeter Wall Cluster 26A & 28A & Cluster 26C & 28C</p> <p>Foundation Details</p>	<p>HEET NO.:</p> <p>S-5</p> <p>DATE: April 20, 2021</p>
	<p>LOCATION: Casa Real Townhouse, Real Street, Urdaneta Village, Marikina City</p>						

LOT 2 - SWIMMING POOL

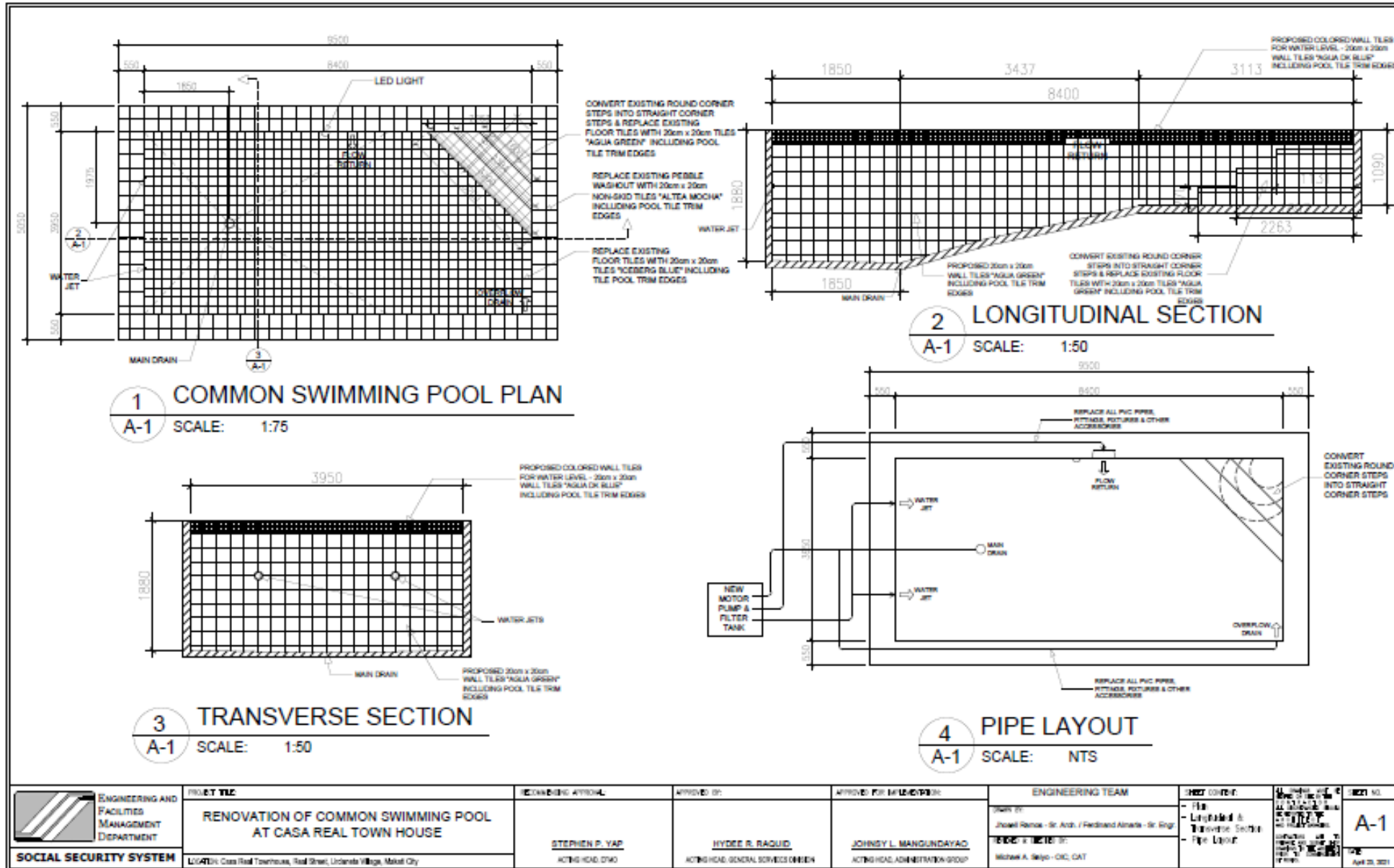

<p>ENGINEERING AND FACILITIES MANAGEMENT DEPARTMENT</p>	<p>PROJECT TITLE</p> <p>RENOVATION OF COMMON SWIMMING POOL AT CASA REAL TOWN HOUSE</p>	<p>ENGINEERING APPROVAL</p> <p>STEPHEN P. YAP ACTING HEAD, DMO</p>	<p>APPROVED BY:</p> <p>HYDEE S. RAQUID ACTING HEAD, GENERAL SERVICES DIVISION</p>	<p>APPROVED FOR IMPLEMENTATION:</p> <p>JOHNSY L. MANGUNDAYAO ACTING HEAD, ADMINISTRATION GROUP</p>	<p>ENGINEERING TEAM</p> <p>DESIGN BY: Jozwell Ramon - Sr. Arch. / Ferdinand Almaraz - Sr. Engr.</p> <p>CHECK & VERIFY BY: Mikhael A. Salayo - OIC, OAT</p>	<p>HEET CONTENT:</p> <ul style="list-style-type: none"> - Plan - Longitudinal Section - Transverse Section - Pipe Layout 	<p>PROJECT NO.</p> <p>A-1</p> <p>DATE:</p> <p>April 23, 2021</p>
	<p>SOCIAL SECURITY SYSTEM</p> <p>Location: Casa Real Townhouse, Real Street, Urdaneta Village, Marikina City</p>						

LOT 3 - WATERPROOFING OF ROOFDECK

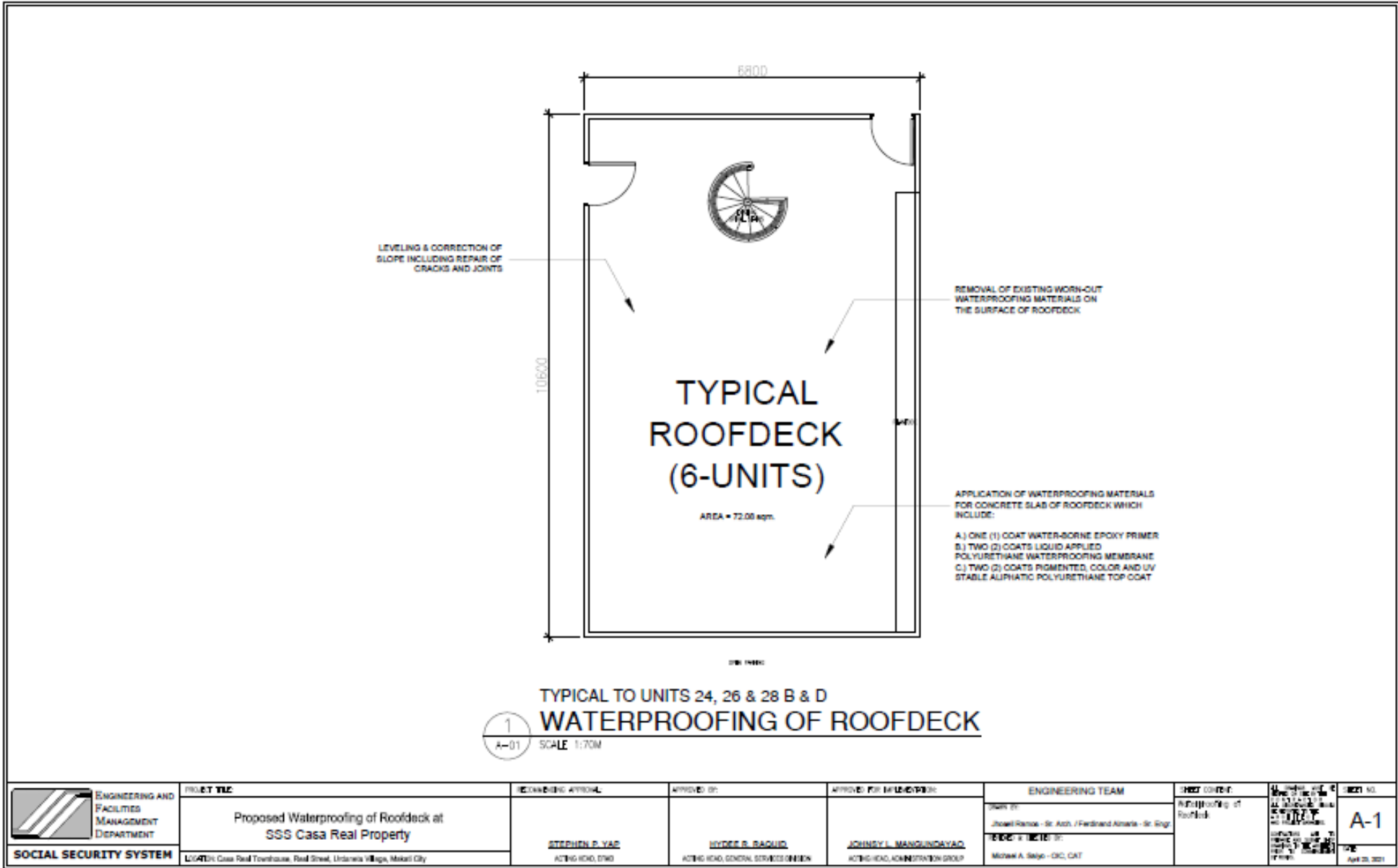

Section VIII. Bill of Quantities

PROJECT : REPAIR OF CASA REAL FENCE AT SSS URDANETA VILLAGE PROPERTIES
 LOCATION : Casa Real Townhouse, Real Street, Urdaneta Village, Makati City

LOT 1 - PERIMETER FENCE

BILL OF QUANTITIES FORM

ITEM	DESCRIPTION	QTY.	UNIT	MATERIALS		LABOR & EQUIPMENT		MOB. / DEMOB.	TOTAL DIRECT COST	MARK-UP	VAT	TOTAL COST
				UNIT COST	TOTAL	UNIT COST	TOTAL					
(A)	(B)	(C)	(D)	(E)	(F) (C * E)	(G)	(H) (C * G)	(I) % * (F+H)	(J) (F + H + I)	(K) % * (J)	(L) 12% * (J+K)	(M) (J + K + L)
1	General Requirements											
1.1	Renovation Permits / Clearances, As-built plans	1.00	lot		-		-		-		-	-
1.2	Temporary Facilities and Board-up/Site Enclosure, Water and Electricity Consumption	1.00	lot		-		-		-		-	-
	Sub-total 1- General Requirements										=	-
2	Site Preparation											
2.1	Demolition of Existing Fence	1.00	lot		-		-		-		-	-
2.2	Excavation, Backfilling & Restoration of affected structures	1.00	lot		-		-		-		-	-
2.3	Trimming/Cutting of excess tree roots	1.00	lot		-		-		-		-	-
2.4	Hauling & Disposal of Debris & Waste Materials	1.00	lot		-		-		-		-	-
	Sub-total 2- Site Preparation										=	-
3	Perimeter Fence Repair											
3.1	CHB #6"	1,220.00	pcs		-		-		-		-	-
3.2	Sand	23.00	cu.m.		-		-		-		-	-
3.3	Gravel	18.00	cu.m.		-		-		-		-	-
3.4	Cement, 40 kg	170.00	bags		-		-		-		-	-
3.5	Tie Wire (standard)	15.00	kg.		-		-		-		-	-
3.6	DBS steel bar #10mm x 6m	98.00	pcs		-		-		-		-	-
3.7	DBS steel bar #12mm x 6m	55.00	pcs		-		-		-		-	-
3.8	DBS steel bar #16mm x 6m	52.00	pcs		-		-		-		-	-
3.9	Ordinary Nail #2	7.00	kg.		-		-		-		-	-
3.10	Ordinary Nail #3	7.00	kg.		-		-		-		-	-
3.11	Plywood (12mm) Penolic Board	15.00	pcs		-		-		-		-	-
3.12	Cocolumber 2x2x12	30.00	pcs		-		-		-		-	-
3.13	Wall Paint (beige color)	3.00	tin		-		-		-		-	-
3.14	Concrete chemicals	3.00	gal		-		-		-		-	-
3.15	7" Paint Roller (Cloth)	2.00	pcs		-		-		-		-	-
3.16	Fixed Security Grills for Trees	1.00	lot		-		-		-		-	-
	Sub-total 3- Perimeter Fence Repair										=	-
	TOTAL PROJECT COST (ΣSubtotals 1, 2, 3)										=	-

GENERAL CONDITIONS:

1. For uniformity and evaluation purposes, a bidder shall adhere to the herein prescribed format of BOQ, specifically in the formula for computation, given quantity and exclusive pay items. Any deviation from the format shall be a ground
1.1 Fill up all required items/field in the BOQ. Failure to indicate any of the following shall mean outright disqualification since bid is considered Non-responsive:
 - a) if item is given for free, indicate dash (-), zero (0) or free
 - b) If the item is not applicable, indicate N/A
2. Each bidder shall be provided with hard copy of the BOQ Form (attached in the PBD) and an electronic copy for faster and easier encoding. The hard copy shall serve as the bidder's reference as to completeness of work items, quantity,
3. Bidder are not allowed to include any pay items that were not indicated in the form supplied Bill of Quantities. In instances where necessary work items are inadvertently left out in BOQ Form, a bidder should make a written query to
4. Bidders shall include in the detailed estimate the breakdown of materials & labor for quantities specified in LOT (unit of measure) in BOQ
5. All documents must be signed, and each and every page thereof must be initialed by the duly authorized representative/s of the Bidder
6. Mark-up shall include the following:
 - 6.1 Overhead expenses such as office expenses, supervision, transportation allowances, and financing costs (Premium on CARI, Bid Security, Performance Security, Surety for advance payment, Warranty bond)
 - 6.2 Contingencies, Miscellaneous Expenses and Contractor's Profit margin
7. It is the responsibility of the Bidder to check the arithmetical computation provided herein.

Submitted by:

(Name of Bidder / Company Name)

Prepared by:

(Company Representative - Signature over printed name)

Address:

Telephone #:

Date:

LOT 2 - SWIMMING POOL

PROJECT : REPAIR OF SWIMMING POOL AT SSS URDANETA VILLAGE PROPERTIES
LOCATION : Casa Real Townhouse, Real Street, Urdaneta Village, Makati City

BILL OF QUANTITIES FORM

ITEM	DESCRIPTION	QTY.	UNIT	MATERIALS		LABOR & EQUIPMENT		MOB. / DEMOB. (I) % * (F+H)	TOTAL DIRECT COST (J) (F + H + I)	MARK-UP (K) % * (J)	VAT (L) 12% * (J+K)	TOTAL COST (M) (J + K + L)
				UNIT COST (E)	TOTAL (F) (C * E)	UNIT COST (G)	TOTAL (H) (C * G)					
1	General Requirements											
1.1	Renovation Permits / Clearances, As-built plans	1.00	lot		-		-		-		-	-
1.2	Temporary Facilities and Board-up/Site Enclosure, Water and Electricity Consumption	1.00	lot		-		-		-		-	-
	Sub-total 1- General Requirements										=	-
2	Site Preparation											
2.1	Dismantling of Existing Wall and Floor Tiles	100.00	sq.m.		-		-		-		-	-
2.2	Hauling & Disposal of Debris & Waste Materials	1.00	lot		-		-		-		-	-
	Sub-total 2- Site Preparation										=	-
3	Architectural / Specialty Works											
3.1	Floor Tiles, 20cm x 20cm, Mosaic Design " Iceberg Blue" (30.62 m2)	842.00	pcs		-		-		-		-	-
3.2	Steps Tiles, 20cm x 20cm, "Agua Green" (4.50 m2)	125.00	pcs		-		-		-		-	-
3.3	Wall Tiles, 20cm x 20cm, "Agua Green" (30.74 m2)	845.00	pcs		-		-		-		-	-
3.4	Wall Tiles For Water Level, 20cm x 20cm, "Agua DK Green" (4.94 m2)	136.00	pcs		-		-		-		-	-
3.5	Walk Pavement Tiles, 20cm x 20cm, Non-Skid "Altea Mocha" (14.80 m2)	407.00	pcs		-		-		-		-	-
3.6	Tile Adhesive, Heavy Duty, 25 kg/bag	20.00	bag		-		-		-		-	-
3.7	Tile Grout, Heavy Duty, 2kg/bag	20.00	bag		-		-		-		-	-
3.8	Waterproofing Cementitious Sealant	30.00	gal		-		-		-		-	-
3.9	Plastering of Walls & Floor	85.60	m2		-		-		-		-	-
	Sub-total 3- Architectural / Specialty Works										=	-
4	Pool Piping System, Equipment & Accessories											
4.1	Filter complete w/ Filter Clamp, O-ring, Pressure Gauge Assembly, Filter Elements & Filter Tank, 36 sq.ft.	1.00	set		-		-		-		-	-
4.2	Swimming Pool Pump & Motor, Maxflo 1 HP complete w/ Pump Basket and Gasket O-ring	1.00	set		-		-		-		-	-
4.3	Eye Ball Fitting Set (1x1/2)	2.00	pcs		-		-		-		-	-
4.4	Multi Variflo Valve (Flow Valve)	1.00	set		-		-		-		-	-

4.5	PVC Ball Valve 1x1/2 thru union	3.00	pcs		-		-		-		-	-
4.6	Vacuum Fitting	1.00	set		-		-		-		-	-
4.7	Hydro Static Valve including accessories	1.00	set		-		-		-		-	-
4.8	Main Drain Cover	3.00	set		-		-		-		-	-
4.9	Return Fittings	3.00	set		-		-		-		-	-
4.10	Pool Piping System, Inlet /Outlet Pipes & Fittings, uPVC Pipe 1-1/2"ø	1.00	lot		-		-		-		-	-
4.11	LED underwater pool light including power supply and accessories	4.00	pcs		-		-		-		-	-
	Sub-total 4- Pool Accessories										=	-
	TOTAL PROJECT COST (ΣSubtotals 1, 2, 3 & 4)										=	-

GENERAL CONDITIONS:

1. For uniformity and evaluation purposes, a bidder shall adhere to the herein prescribed format of BOQ, specifically in the formula for computation, given quantity and exclusive pay items. Any deviation from the format shall be a ground
 - 1.1 Fill up all required items/field in the BOQ. Failure to indicate any of the following shall mean outright disqualification since bid is considered Non-responsive:
 - a) if item is given for free, indicate dash (-), zero (0) or free
 - b) If the item is not applicable, indicate N/A
2. Each bidder shall be provided with hard copy of the BOQ Form (attached in the PBD) and an electronic copy for faster and easier encoding. The hard copy shall serve as the bidder's reference as to completeness of work items,
3. Bidder are not allowed to include any pay items that were not indicated in the form supplied Bill of Quantities. In instances where necessary work items are inadvertently left out in BOQ Form, a bidder should make a written query to
4. Bidders shall include in the detailed estimate the breakdown of materials & labor for quantities specified in LOT (unit of measure) in BOQ
5. All documents must be signed, and each and every page thereof must be initialed by the duly authorized representative/s of the Bidder
6. Mark-up shall include the following:
 - 6.1 Overhead expenses such as office expenses, supervision, transportation allowances, and financing costs (Premium on CARI, Bid Security, Performance Security, Surety for advance payment, Warranty bond)
 - 6.2 Contingencies, Miscellaneous Expenses and Contractor's Profit margin
7. It is the responsibility of the Bidder to check the arithmetical computation provided herein.

Submitted by: _____
(Name of Bidder / Company Name)

Prepared by: _____
(Company Representative - Signature over printed name)

Address: _____

Telephone #: _____

Date: _____

LOT 3 – WATERPROOFING OF ROOFDECKS

PROJECT : WATERPROOFING OF ROOFDECKS AT SSS URDANETA VILLAGE PROPERTIES

LOCATION : Casa Real Townhouse, Real Street, Urdaneta Village, Makati City

BILL OF QUANTITIES FORM

ITEM	DESCRIPTION	QTY.	UNIT	MATERIALS		LABOR & EQUIPMENT		MOB. / DEMOB. (I) % * (F+H)	TOTAL DIRECT COST (J) (F + H + I)	MARK-UP (K) % * (J)	VAT (L) 12% * (J+K)	TOTAL COST (M) (J + K + L)
				UNIT COST (E)	TOTAL (F) (C * E)	UNIT COST (G)	TOTAL (H) (C * G)					
1	General Requirements											
1.1	Renovation Permits / Clearances, As-built plans	1.00	lot		-		-		-		-	-
1.2	Temporary Facilities and Board-up/Site Enclosure, Water and Electricity Consumption	1.00	lot		-		-		-		-	-
	Sub-total 1- General Requirements										=	-
2	Site Preparation											
2.1	Removal of existing worn-out waterproofing materials on the surface of roofdeck	450.00	m2		-		-		-		-	-
2.2	Hauling & Disposal of Debris & Waste Materials	1.00	lot		-		-		-		-	-
	Sub-total 2- Site Preparation										=	-
3	Waterproofing Works											
3.1	Repair of cracks & joints	450.00	m2		-		-		-		-	-
3.2	Levelling & correction of slope	450.00	m2		-		-		-		-	-
3.3	Application of Waterproofing Materials for Concrete Slab of Roofdeck which include: a.) one (1) coat water-borne epoxy primer b.) two (2) coats liquid applied polyurethane waterproofing membrane c.) two (2) coats pigmented, color and UV stable aliphatic polyurethane top coat	450.00	m2		-		-		-		-	-
3.4	Water leak & flood testing	1.00	lot		-		-		-		-	-
	Sub-total 3-Waterproofing Works										=	-
	TOTAL PROJECT COST (ΣSubtotals 1, 2, 3)										=	-

GENERAL CONDITIONS:

1. For uniformity and evaluation purposes, a bidder shall adhere to the herein prescribed format of BOQ, specifically in the formula for computation, given quantity and exclusive pay items. Any deviation from the format shall be a ground
1.1 Fill up all required items/field in the BOQ. Failure to indicate any of the following shall mean outright disqualification since bid is considered Non-responsive:
 - a) if item is given for free, indicate dash (-), zero (0) or free
 - b) If the item is not applicable, indicate N/A
2. Each bidder shall be provided with hard copy of the BOQ Form (attached in the PBD) and an electronic copy for faster and easier encoding. The hard copy shall serve as the bidder's reference as to completeness of work items,
3. Bidder are not allowed to include any pay items that were not indicated in the form supplied Bill of Quantities. In instances where necessary work items are inadvertently left out in BOQ Form, a bidder should make a written query to
4. Bidders shall include in the detailed estimate the breakdown of materials & labor for quantities specified in LOT (unit of measure) in BOQ
5. All documents must be signed, and each and every page thereof must be initialed by the duly authorized representative/s of the Bidder
6. Mark-up shall include the following:
 - 6.1 Overhead expenses such as office expenses, supervision, transportation allowances, and financing costs (Premium on CARI, Bid Security, Performance Security, Surety for advance payment, Warranty bond)
 - 6.2 Contingencies, Miscellaneous Expenses and Contractor's Profit margin
7. It is the responsibility of the Bidder to check the arithmetical computation provided herein.

Submitted by:

(Name of Bidder / Company Name)

Prepared by:

(Company Representative - Signature over printed name)

Address:

Telephone #:

Date:

Section IX. Checklist of Technical and Financial Documents

Checklist of Technical and Financial Documents

I. TECHNICAL COMPONENT ENVELOPE

Class “A” Documents

Legal Documents

- (a) Valid PhilGEPS Registration Certificate (Platinum Membership) (all pages);
or
- (b) Registration certificate from Securities and Exchange Commission (SEC), Department of Trade and Industry (DTI) for sole proprietorship, or Cooperative Development Authority (CDA) for cooperatives or its equivalent document;
and
- (c) Mayor’s or Business permit issued by the city or municipality where the principal place of business of the prospective bidder is located, or the equivalent document for Exclusive Economic Zones or Areas;
and
- (e) Tax clearance per E.O. No. 398, s. 2005, as finally reviewed and approved by the Bureau of Internal Revenue (BIR).

Technical Documents

- (f) Statement of the prospective bidder of all its ongoing government and private contracts, including contracts awarded but not yet started, if any, whether similar or not similar in nature and complexity to the contract to be bid; **and**
- (g) Statement of the bidder’s Single Largest Completed Contract (SLCC) similar to the contract to be bid, except under conditions provided under the rules;
and
- (h) Philippine Contractors Accreditation Board (PCAB) License;
or
Special PCAB License in case of Joint Ventures;
and registration for the type and cost of the contract to be bid; **and**
- (i) Original copy of Bid Security. If in the form of a Surety Bond, submit also a certification issued by the Insurance Commission;
or
Original copy of Notarized Bid Securing Declaration; **and**
- (j) Project Requirements, which shall include the following:
 - a. Organizational chart for the contract to be bid;
 - b. List of contractor’s key personnel (*e.g.*, Project Manager, Project Engineers, Materials Engineers, and Foremen), to be assigned to the contract to be bid, with their complete qualification and experience data;
 - c. List of contractor’s major equipment units, which are owned, leased, and/or under purchase agreements, supported by proof of ownership or certification of availability of equipment from the equipment lessor/vendor for the duration of the project, as the case may be; **and**
- (k) Original duly signed Omnibus Sworn Statement (OSS);
and if applicable, Original Notarized Secretary’s Certificate in case of a corporation, partnership, or cooperative; or Original Special Power of Attorney of all members of the joint venture giving full power and authority to its officer to sign the OSS and do acts to represent the Bidder.

Financial Documents

- (l) The prospective bidder’s audited financial statements, showing, among others, the prospective bidder’s total and current assets and liabilities, stamped “received” by the BIR or its duly accredited and authorized institutions, for the preceding calendar year which should not be earlier than two (2) years from the date of bid submission; **and**
- (m) The prospective bidder’s computation of Net Financial Contracting Capacity (NFCC).

Class “B” Documents

- (n) If applicable, duly signed joint venture agreement (JVA) in accordance with RA No. 4566 and its IRR in case the joint venture is already in existence;
or
duly notarized statements from all the potential joint venture partners stating that they will enter into and abide by the provisions of the JVA in the instance that the bid is successful.

II. FINANCIAL COMPONENT ENVELOPE

- (o) Original of duly signed and accomplished Financial Bid Form; **and**

Other documentary requirements under RA No. 9184

- (p) Original of duly signed Bid Prices in the Bill of Quantities; **and**
 (q) Duly accomplished Detailed Estimates Form, including a summary sheet indicating the unit prices of construction materials, labor rates, and equipment rentals used in coming up with the Bid; **and**
 (r) Cash Flow by Quarter.

IMPORTANT REMINDERS

- A) Each and every page of the **Bid Forms/Price Schedule(s)/Bid Breakdown**, under Section IX: Checklist of Technical and Financial Documents hereof, shall be signed by the duly authorized representative/s of the Bidder. Failure to do so shall be a ground for the rejection of the bid.
- B) Any interlineations, erasures, or overwriting shall be valid only if they are signed or initialed by the duly authorized representative/s of the Bidder.
- C) Bid documents shall be compiled in a folder/binder with the Annexes properly labeled with tabs/separators.
- D) Bidders shall submit their bids through their duly authorized representative enclosed in separate sealed envelopes, which shall be submitted simultaneously:
- a) The first three individually sealed envelopes shall contain the folder/binder of the Eligibility Requirements and Technical Component of the bid; prepared in three copies labeled as follows:
- Envelop (1): ORIGINAL – Eligibility Requirements and Technical Component
Envelop (2): COPY1 – Eligibility Requirements and Technical Component
Envelop (3): COPY2 – Eligibility Requirements and Technical Component
- b) The next three individually sealed envelopes shall contain the folder/binder of the Financial Component of the bid; prepared in three copies labeled as follows:
- Envelop (4): ORIGINAL – Financial Component
Envelop (5): COPY1 – Financial Component
Envelop (6): COPY2 – Financial Component
- c) Bidders shall enclose, seal and mark the following:
- Envelop (7): Envelope (1) and Envelope (4) enclosed in one sealed envelope marked “ORIGINAL–BID”
- Envelop (8): Envelope (2) and Envelope (5) enclosed in one sealed envelope marked “COPY1–BID”
- Envelop (9): Envelope (3) and Envelope (6) enclosed in one sealed envelope marked “COPY2–BID”

- d) Envelopes (7) to (9) shall then be enclosed in a single sealed, signed final/outer envelope/package/box
- e) All envelopes (Envelopes (1) to (9) and the final/outer envelope/package/box) shall indicate the following:
 - addressed to the Procuring Entity’s BAC
 - name and address of the Bidder in capital letters
 - name of the contract/project to be bid in capital letters
 - bear the specific identification/reference code of this bidding process
 - bear a warning “DO NOT OPEN BEFORE...” the date and time for the opening of bids

<p>THE CHAIRPERSON</p> <p>BIDS AND AWARDS COMMITTEE</p> <p>2ND FLOOR, SSS MAIN BUILDING</p> <p>EAST AVENUE, DILIMAN, QUEZON CITY</p> <p>NAME OF BIDDER : _____</p> <p>ADDRESS : _____</p>

- E) Bids submitted after the deadline shall only be marked for recording purpose, shall not be included in the opening of bids, and shall be returned to the bidder unopened.
- F) Bidders shall submit a copy of the Authority to Notarize issued by the Regional Trial Court to the Notarial Public.

FORMS

Bid Form for the Procurement of Infrastructure Projects

BID FORM

VARIOUS PROJECT AT SSS-OWNED PROPERTY AT URDANETA VILLAGE

Date: _____

Project Identification No.: _____

To: **SOCIAL SECURITY SYSTEM**

East Avenue, Diliman, Quezon City

Having examined the Philippine Bidding Documents (PBDs) including the Supplemental or Bid Bulletin Numbers [insert numbers], the receipt of which is hereby duly acknowledged, we, the undersigned, declare that:

- a. We have no reservation to the PBDs, including the Supplemental or Bid Bulletins, for the Procurement Project: **(Insert name of contract)**;
- b. We offer to execute the Works for this Contract in accordance with the PBDs;
- a. The total price of our Bid in words and figures, excluding any discounts offered below is: **(insert information)**;
- b. The discounts offered and the methodology for their application are: (insert information);
- c. The total bid price includes the cost of all taxes, such as, but not limited to: [specify the applicable taxes, e.g. (i) value added tax (VAT), (ii) income tax, (iii) local taxes, and (iv) other fiscal levies and duties], which are itemized herein and reflected in the detailed estimates,
- d. Our Bid shall be valid within the period stated in the PBDs, and it shall remain binding upon us at any time before the expiration of that period;
- e. If our Bid is accepted, we commit to obtain a Performance Security in the amount of **[insert percentage amount]** percent of the Contract Price for the due performance of the Contract, or a Performance Securing Declaration in lieu of the allowable forms of Performance Security, subject to the terms and conditions of issued GPPB guidelines for this purpose;
- f. We are not participating, as Bidders, in more than one Bid in this bidding process, other than alternative offers in accordance with the Bidding Documents;
- g. We understand that this Bid, together with your written acceptance thereof included in your notification of award, shall constitute a binding contract between us, until a formal Contract is prepared and executed; and
- h. We understand that you are not bound to accept the Lowest Calculated Bid or any other Bid that you may receive.
- i. We likewise certify/conform that the undersigned, is the duly authorized representative of the bidder, and granted full power and authority to do, execute and perform any and all acts necessary to participate, submit the bid, and to sign and execute the ensuing contract for the **(Name of Project)** of the [Name of the Procuring Entity].

- j. We acknowledge that failure to sign each and every page of this Bid Form, including the Bill of Quantities, shall be a ground for the rejection of our bid.

Name: _____

Legal capacity: _____

Signature: _____

Duly authorized to sign the Bid for and behalf of: _____

Date: _____

GPPB Resolution No. 16-2020, dated 16 September 2020

Bid Securing Declaration Form

REPUBLIC OF THE PHILIPPINES) CITY OF
_____) S.S.

BID SECURING DECLARATION

Project Identification No.: [Insert number]

To: *[Insert name and address of the Procuring Entity]*

I/We, the undersigned, declare that:

1. I/We understand that, according to your conditions, bids must be supported by a Bid Security, which may be in the form of a Bid Securing Declaration.
2. I/We accept that: (a) I/we will be automatically disqualified from bidding for any procurement contract with any procuring entity for a period of two (2) years upon receipt of your Blacklisting Order; and, (b) I/we will pay the applicable fine provided under Section 6 of the Guidelines on the Use of Bid Securing Declaration, within fifteen (15) days from receipt of the written demand by the procuring entity for the commission of acts resulting to the enforcement of the bid securing declaration under Sections 23.1(b), 34.2, 40.1 and 69.1, except 69.1(f), of the IRR of RA No. 9184; without prejudice to other legal action the government may undertake.
3. I/We understand that this Bid Securing Declaration shall cease to be valid on the following circumstances:
 - a. Upon expiration of the bid validity period, or any extension thereof pursuant to your request;
 - b. I am/we are declared ineligible or post-disqualified upon receipt of your notice to such effect, and (i) I/we failed to timely file a request for reconsideration or (ii) I/we filed a waiver to avail of said right; and
 - c. I am/we are declared the bidder with the Lowest Calculated Responsive Bid, and I/we have furnished the performance security and signed the Contract.

IN WITNESS WHEREOF, I/We have hereunto set my/our hand/s this ____ day of *[month]*
[year] at *[place of execution]*.

*[Insert NAME OF BIDDER OR ITS AUTHORIZED
REPRESENTATIVE]
[Insert signatory's legal capacity] Affiant*

[Jurat]

[Format shall be based on the latest Rules on Notarial Practice]

GPPB Resolution No. 16-2020, dated 16 September 2020

**Contract Agreement Form for the
Procurement of Infrastructure Projects (Revised)**

*[not required to be submitted with the Bid, but it shall be submitted within ten (10) days
after receiving the Notice of Award]*

CONTRACT AGREEMENT

THIS AGREEMENT made between:

SOCIAL SECURITY SYSTEM, a government-owned and controlled corporation created pursuant to Republic Act No. 11199, with principal office address at SSS Building, East Avenue, Diliman, Quezon City, represented herein by its Approving Authority and (Position of Approving Authority), (Name of Approving Authority) and (Position of Signatory), (Name of signatory), duly authorized pursuant to Administrative Order _____, _____ (pertaining to Approving Authority) (Annex “A”) and Office Order _____, _____ (Annex “B”) (pertaining to signatories), hereinafter referred to as the “SSS”;

- a n d -

(NAME OF CONTRACTOR), of legal age, Filipino, single/married, with principal address at _____, hereinafter referred to as the “Contractor”.

If corporation

(NAME OF CONTRACTOR), a corporation duly created and existing pursuant to the laws of the Republic of the Philippines, with principal office address at _____, represented herein by its (Position of Signatory), (Name of Signatory), duly authorized pursuant to _____, _____, hereinafter referred to as the “Contractor”.

WHEREAS, the Entity is desirous that the Contractor execute [name and identification number of contract] (hereinafter called “the Works”) and the Entity has accepted the Bid for [contract price in words and figures in specified currency] by the Contractor for the execution and completion of such Works and the remedying of any defects therein.

NOW THIS AGREEMENT WITNESSETH AS FOLLOWS:

1. In this Agreement words and expressions shall have the same meanings as are respectively assigned to them in the Conditions of Contract referred to.
2. The following documents as required by the 2016 revised Implementing Rules and Regulations of Republic Act No. 9184 shall be deemed to form and be read and construed as integral part of this Agreement, *viz.*:
 - a. Philippine Bidding Documents (PBDs);
 - i. Drawings/Plans;
 - ii. Specifications;
 - iii. Bill of Quantities;
 - iv. General and Special Conditions of Contract;
 - v. Supplemental or Bid Bulletins, if any

- b. Contractor's bidder's bid, including the Eligibility requirements, Technical and Financial Proposals, and all other documents or statements submitted;

Bid form, including all the documents/statements contained in the Bidder's bidding envelopes, as annexes, and all other documents submitted (e.g., Bidder's response to request for clarifications on the bid), including corrections to the bid, if any, resulting from the Procuring Entity's bid evaluation;

- c. Performance Security;
- d. Notice of Award of Contract; and the Bidder's conforme thereto; and
- e. Other contract documents that may be required by existing laws and/or the Procuring Entity concerned in the PBDs. **Winning bidder agrees that additional contract documents or information prescribed by the GPPB that are subsequently required for submission after the contract execution, such as the Notice to Proceed, Variation Orders, and Warranty Security, shall likewise form part of the Contract.**

- 3. In consideration for the sum of *[total contract price in words and figures]* or such other sums as may be ascertained, *[Named of the bidder]* agrees to *[state the object of the contract]* in accordance with his/her/its Bid.
- 4. The SSS agrees to pay the above-mentioned sum in accordance with the terms of the Bidding.

IN WITNESS whereof the parties hereto have caused this Agreement to be executed in accordance with the laws of the Republic of the Philippines on the day and year first above written.

[Insert Name and Signature]

[Insert Name and Signature]

[Insert Signatory's Legal Capacity]

[Insert Signatory's Legal Capacity]

for:

for:

SSS

[Insert Name of Supplier]

(In case of double acknowledgment)

SIGNED IN THE PRESENCE OF:

(Name of Certifying officer as to availability of funds)
(Position of Certifying Officer)
(Department/Office of Certifying Officer)

FUNDS AVAILABLE:

APP No.: _____

FIRST ACKNOWLEDGMENT

Republic of the Philippines)
_____) S.S.

BEFORE ME, a Notary Public for and in _____, Philippines, on this _____ day of _____ personally appeared:

Name	Competent Evidence of Identity	Date/Place of Issue

known to me to be the same person who executed the foregoing Agreement, consisting of _____ (____) pages, including this page and excluding annexes, and he/she/they acknowledged to me that the same is his/her/their free and voluntary act and deed as well as the free and voluntary act and deed of the principal he/she /they represent/s in this instance.

WITNESS MY HAND AND SEAL on the date and place first above written.

Doc. No. _____;
Page No. _____;
Book No. _____;
Series of 20__.

SIGNED IN THE PRESENCE OF:

SECOND ACKNOWLEDGMENT

Republic of the Philippines)
_____) S.S.

BEFORE ME, a Notary Public for and in _____, Philippines, on this _____ day of _____ personally appeared:

Name	Competent Evidence of Identity	Date/Place of Issue

known to me to be the same person who executed the foregoing Agreement, consisting of _____ (____) pages, including this page and excluding annexes, and he/she/they acknowledged to me that the same is his/her/their free and voluntary act and deed (if **corporation to include succeeding phrase**) as well as the free and voluntary act and deed of the principal he/she /they represent/s in this instance.

WITNESS MY HAND AND SEAL on the date and place first above written.

Doc. No. _____;
Page No. _____;
Book No. _____;
Series of 20__.

Omnibus Sworn Statement (Revised)

REPUBLIC OF THE PHILIPPINES)
CITY/MUNICIPALITY OF _____) S.S.

AFFIDAVIT

I, *[Name of Affiant]*, of legal age, *[Civil Status]*, *[Nationality]*, and residing at *[Address of Affiant]*, after having been duly sworn in accordance with law, do hereby depose and state that:

1. **Select one, delete the other:**

[If a sole proprietorship:] I am the sole proprietor or authorized representative of *[Name of Bidder]* with office address at *[address of Bidder]*;

[If a partnership, corporation, cooperative, or joint venture:] I am the duly authorized and designated representative of *[Name of Bidder]* with office address at *[address of Bidder]*;

2. **Select one, delete the other:**

[If a sole proprietorship:] As the owner and sole proprietor, or authorized representative of *[Name of Bidder]*, I have full power and authority to do, execute and perform any and all acts necessary to participate, submit the bid, and to sign and execute the ensuing contract for *[Name of the Project]* of the *[Name of the Procuring Entity]* as shown in the attached duly notarized Special Power of Attorney;

[If a partnership, corporation, cooperative, or joint venture:] I am granted full power and authority to do, execute and perform any and all acts necessary to participate, submit the bid, and to sign and execute the ensuing contract for *[Name of the Project]* of the *[Name of the Procuring Entity]*, as shown in the attached *[state title of attached documents showing proof of authorization (e.g., duly notarized Secretary's Certificate, Board/Partnership Resolution, or Special Power of Attorney, whichever is applicable:)]*;

3. *[Name of Bidder]* is not "blacklisted" or barred from bidding by the Government of the Philippines or any of its agencies, offices, corporations, or Local Government Units, foreign government/foreign or international financing institution whose blacklisting rules have been recognized by the Government Procurement Policy Board, **by itself or by relation, membership, association, affiliation, or controlling interest with another blacklisted person or entity as defined and provided for in the Uniform Guidelines on Blacklisting;**

4. Each of the documents submitted in satisfaction of the bidding requirements is an authentic copy of the original, complete, and all statements and information provided therein are true and correct;

5. *[Name of Bidder]* is authorizing the Head of the Procuring Entity or its duly authorized representative(s) to verify all the documents submitted;

6. **Select one, delete the rest:**

[If a sole proprietorship:] The owner or sole proprietor is not related to the Head of the Procuring Entity, members of the Bids and Awards Committee (BAC), the Technical Working Group, and the BAC Secretariat, the head of the Project Management Office or the end-user unit, and the project consultants by consanguinity or affinity up to the third civil degree;

[If a partnership or cooperative:] None of the officers and members of *[Name of Bidder]* is related to the Head of the Procuring Entity, members of the Bids and Awards Committee (BAC), the Technical Working Group, and the BAC Secretariat, the head of the Project Management Office or the end-user unit, and the project consultants by consanguinity or affinity up to the third civil degree;

[If a corporation or joint venture:] None of the officers, directors, and controlling stockholders of *[Name of Bidder]* is related to the Head of the Procuring Entity, members of the Bids and Awards Committee (BAC), the Technical Working Group, and the BAC Secretariat, the head of the Project Management Office or the end-user unit, and the project consultants by consanguinity or affinity up to the third civil degree;

7. *[Name of Bidder]* complies with existing labor laws and standards; and
8. *[Name of Bidder]* is aware of and has undertaken the responsibilities as a Bidder in compliance with the Philippine Bidding Documents, which includes:
 - a) Carefully examining all of the Bidding Documents;
 - b) Acknowledging all conditions, local or otherwise, affecting the implementation of the Contract;
 - c) Making an estimate of the facilities available and needed for the contract to be bid, if any; and
 - d) Inquiring or securing Supplemental/Bid Bulletin(s) issued for the *[Name of the Project]*.
9. *[Consultant]* did not give or pay directly or indirectly, any commission, amount, fee, or any form of consideration, pecuniary or otherwise, to any person or official, personnel or representative of the government in relation to any procurement project or activity.
10. **In case advance payment was made or given, failure to perform or deliver any of the obligations and undertakings in the contract shall be sufficient grounds to constitute criminal liability for Swindling (Estafa) or the commission of fraud with unfaithfulness or abuse of confidence through misappropriating or converting any payment received by a person or entity under an obligation involving the duty to deliver certain goods or services, to the prejudice of the public and the government of the Philippines pursuant to Article 315 of Act No. 3815 s.1930, as amended, or the Revised Penal Code.**

IN WITNESS WHEREOF, I have hereunto set my hand this ___ day of ___, 20__ at _____, Philippines.

[Insert NAME OF BIDDER OR ITS AUTHORIZED REPRESENTATIVE]

[Insert signatory's legal capacity]

Affiant

[Jurat]

[Format shall be based on the latest Rules on Notarial Practice]

GPPB Resolution No. 16-2020, dated 16 September 2020

Performance Securing Declaration (Revised)

[As alternative performance security to be submitted by the winning bidder within ten (10) days from receipt of Notice of Award]

REPUBLIC OF THE PHILIPPINES)

CITY OF _____) S.S.

PERFORMANCE SECURING DECLARATION

Invitation to Bid: [Insert Reference Number indicated in the Bidding Documents] To: [Insert name and address of the Procuring Entity]

I/We, the undersigned, declare that:

1. I/We understand that, according to your conditions, to guarantee the faithful performance by the supplier/distributor/manufacturer/contractor/consultant of its obligations under the Contract, I/we shall submit a Performance Securing Declaration within a maximum period of ten (10) calendar days from the receipt of the Notice of Award prior to the signing of the Contract.
2. I/We accept that: I/we will be automatically disqualified from bidding for any procurement contract with any procuring entity for a period of one (1) year for the first offense, or two (2) years **for the second offense**, upon receipt of your Blacklisting Order if I/We have violated my/our obligations under the Contract;
3. I/We understand that this Performance Securing Declaration shall cease to be valid upon:
 - a. issuance by the Procuring Entity of the Certificate of Final Acceptance, subject to the following conditions:
 - i. Procuring Entity has no claims filed against the contract awardee;
 - ii. It has no claims for labor and materials filed against the contractor; and
 - iii. Other terms of the contract; or
 - b. replacement by the winning bidder of the submitted PSD with a performance security in any of the prescribed forms under Section 39.2 of the 2016 revised IRR of RA No. 9184 as required by the end-user.

IN WITNESS WHEREOF, I/We have hereunto set my/our hand/s this ____ day of [month] [year] at [place of execution].

[Insert NAME OF BIDDER OR ITS

AUTHORIZED REPRESENTATIVE]

[Insert signatory's legal capacity]

Affiant

[Jurat]

[Format shall be based on the latest Rules on Notarial Practice]

FORM-06

STATEMENT OF ALL ITS ON-GOING GOVERNMENT AND PRIVATE CONTRACTS, INCLUDING CONTRACTS AWARDED BUT NOT YER STARTED

NAME OF CONTRACT	DATE OF CONTRACT	CONTRACT DURATION	OWNER'S NAME, ADDRESS, CONTACT NUMBERS AND E-MAIL ADDRESS	KINDS OF GOODS	AMOUNT OF CONTRACT	VALUE OF OUTSTANDING CONTRACT	REMARKS (Indicate "With NDA" or "Without NDA")

Note: Including projects that are under Non-Disclosure Agreement (NDA)

FORM-07

STATEMENT OF SINGLE LARGEST COMPLETED CONTRACT SIMILAR TO THE PROJECT TO BE BID EQUIVALENT TO AT LEAST 50% OF THE ABC WITH ATTACHED SUPPORTING DOCUMENTS (i.e. P.O/CONTRACTS)

NAME OF CONTRACT	KINDS OF GOODS	AMOUNT OF CONTRACT	CONTACT PERSON, CONTACT NO., ADDRESS, AND EMAIL ADDRESS

Formula in the Computation of NFCC

 NAME OF PROJECT

 NAME OF COMPANY

NFCC = 15 (Current Assets – Current Liabilities) – Value of All Outstanding Works under On-going Contracts including Awarded Contracts yet to be started)

YEAR	CURRENT ASSETS	CURRENT LIABILITIES
TOTAL		

Value of Outstanding Works under On-going Contracts:

CONTRACT DESCRIPTION	TOTAL CONTRACT AMOUNT AT AWARD	PERCENTAGE OF PLANNED AND ACTUAL ACCOMPLISHMENT	ESTIMATED COMPLETION TIME
TOTAL			

Use additional sheet/s, if necessary

FORMULA:

$$15 \left(\frac{\text{Current Assets}}{\text{Current Assets}} - \frac{\text{Current Liabilities}}{\text{Current Liabilities}} \right) - \frac{\text{Total Outstanding Works}}{\text{Total Outstanding Works}} = \text{NFCC}$$

P _____ NFCC

Prepared and Submitted by:

 Signature over Printed Name

(Name of Bank)

COMMITTED LINE OF CREDIT CERTIFICATE

Date: _____

Social Security System (SSS)
SSS Main Building, East Avenue
Diliman, Quezon City

CONTRACT PROJECT	:	_____
COMPANY/FIRM	:	_____
ADDRESS	:	_____
BANK/FINANCING	:	_____
INSTITUTION	:	_____
ADDRESS	:	_____
AMOUNT	:	_____

This is to certify that the above Bank/Financing Institution with business address indicated above, commits to provide the (Supplier/Distributor/Manufacturer/Contractor), if awarded the above-mentioned Contract, a credit line in the amount specified above which shall be exclusively used to finance the performance of the above-mentioned contract subject to our terms, conditions and requirements.

The credit line shall be available within fifteen (15) calendar days after receipt by the (Supplier/Distributor/Manufacturer/Contractor) of the Notice of Award and such line of credit shall be maintained until issuance of Certificate of Acceptance by the Social Security System.

This Certification is being issued in favor of said (Supplier/Distributor/Manufacturer/Contractor) in connection with the bidding requirement of (Name of Procuring Entity) for the above-mentioned Contract. We are aware that any false statements issued by us make us liable for perjury.

The committed line of credit cannot be terminated or cancelled without the prior written approval of Social Security System.

Name and Signature of Authorized Financing Institution Office

Office Designation

Concurred by:

Name & Signature of (Supplier/Distributor/Manufacturer/Contractor) Authorized Representative

Official Designation

SUBSCRIBED AND SWORN TO BEFORE ME this _____ day of _____ at _____
Philippines, Affiant exhibited to me his/her competent Evidence of Identity (as defines by the 2004
Rules on Notarial Practice _____ issued on _____ at _____, Philippines.

NOTARY PUBLIC

Doc No. : _____
Page No. : _____
Book No. : _____
Series of : _____

(Note: The amount committed should be machine validated in the Certificate itself)

