



SOCIAL SECURITY SYSTEM

PHILIPPINE BIDDING DOCUMENTS

Sixth Edition

Procurement of GOODS

**SUPPLY, DELIVERY AND INSTALLATION
OF MODULAR OFFICE SYSTEM AND
FURNITURE FOR VARIOUS SSS BRANCH
OFFICES**

LOT I: NCR AND NEARBY LUZON BRANCHES

LOT II: LUZON BRANCHES

LOT III: VISMIN BRANCHES

ITB-SSS-Goods-2022-089

OCTOBER 2022

Government of the Republic of the Philippines



Regine M. Ignacio
TWG Chairperson

Table of Contents

Glossary of Acronyms, Terms, and Abbreviations	3
Section I. Invitation to Bid.....	6
Section II. Instructions to Bidders.....	9
1. Scope of Bid	10
2. Funding Information.....	10
3. Bidding Requirements	10
4. Corrupt, Fraudulent, Collusive, and Coercive Practices.....	10
5. Eligible Bidders.....	10
6. Origin of Goods	11
7. Subcontracts	11
8. Pre-Bid Conference	11
9. Clarification and Amendment of Bidding Documents	11
10. Documents comprising the Bid: Eligibility and Technical Components	11
11. Documents comprising the Bid: Financial Component	11
12. Bid Prices	12
13. Bid and Payment Currencies	12
14. Bid Security	12
15. Sealing and Marking of Bids	13
16. Deadline for Submission of Bids	13
17. Opening and Preliminary Examination of Bids	13
18. Domestic Preference	13
19. Detailed Evaluation and Comparison of Bids	13
20. Post-Qualification	14
21. Signing of the Contract	14
Section III. Bid Data Sheet	15
Section IV. General Conditions of Contract	18
1. Scope of Contract	19
2. Advance Payment and Terms of Payment	19
3. Performance Security	19
4. Inspection and Tests	19
5. Warranty	19
6. Liability of the Supplier	20
Section V. Special Conditions of Contract	21
Section VI. Schedule of Requirements	28
Section VII. Technical Specifications	30
Section VIII. Checklist of Technical and Financial Documents	52

Glossary of Acronyms, Terms, and Abbreviations

ABC – Approved Budget for the Contract.

BAC – Bids and Awards Committee.

Bid – A signed offer or proposal to undertake a contract submitted by a bidder in response to and in consonance with the requirements of the bidding documents. Also referred to as *Proposal* and *Tender*. (2016 revised IRR, Section 5[c])

Bidder – Refers to a contractor, manufacturer, supplier, distributor and/or consultant who submits a bid in response to the requirements of the Bidding Documents. (2016 revised IRR, Section 5[d])

Bidding Documents – The documents issued by the Procuring Entity as the bases for bids, furnishing all information necessary for a prospective bidder to prepare a bid for the Goods, Infrastructure Projects, and/or Consulting Services required by the Procuring Entity. (2016 revised IRR, Section 5[e])

BIR – Bureau of Internal Revenue.

BSP – Bangko Sentral ng Pilipinas.

Consulting Services – Refer to services for Infrastructure Projects and other types of projects or activities of the GOP requiring adequate external technical and professional expertise that are beyond the capability and/or capacity of the GOP to undertake such as, but not limited to: (i) advisory and review services; (ii) pre-investment or feasibility studies; (iii) design; (iv) construction supervision; (v) management and related services; and (vi) other technical services or special studies. (2016 revised IRR, Section 5[i])

CDA - Cooperative Development Authority.

Contract – Refers to the agreement entered into between the Procuring Entity and the Supplier or Manufacturer or Distributor or Service Provider for procurement of Goods and Services; Contractor for Procurement of Infrastructure Projects; or Consultant or Consulting Firm for Procurement of Consulting Services; as the case may be, as recorded in the Contract Form signed by the parties, including all attachments and appendices thereto and all documents incorporated by reference therein.

CIF – Cost Insurance and Freight.

CIP – Carriage and Insurance Paid.

CPI – Consumer Price Index.

DDP – Refers to the quoted price of the Goods, which means “delivered duty paid.”

DTI – Department of Trade and Industry.

EXW – Ex works.

FCA – “Free Carrier” shipping point.

FOB – “Free on Board” shipping point.

Foreign-funded Procurement or Foreign-Assisted Project– Refers to procurement whose funding source is from a foreign government, foreign or international financing institution as specified in the Treaty or International or Executive Agreement. (2016 revised IRR, Section 5[b]).

Framework Agreement – Refers to a written agreement between a procuring entity and a supplier or service provider that identifies the terms and conditions, under which specific purchases, otherwise known as “Call-Offs,” are made for the duration of the agreement. It is in the nature of an option contract between the procuring entity and the bidder(s) granting the procuring entity the option to either place an order for any of the goods or services identified in the Framework Agreement List or not buy at all, within a minimum period of one (1) year to a maximum period of three (3) years. (GPPB Resolution No. 27-2019)

GFI – Government Financial Institution.

GOCC – Government-owned and/or –controlled corporation.

Goods – Refer to all items, supplies, materials and general support services, except Consulting Services and Infrastructure Projects, which may be needed in the transaction of public businesses or in the pursuit of any government undertaking, project or activity, whether in the nature of equipment, furniture, stationery, materials for construction, or personal property of any kind, including non-personal or contractual services such as the repair and maintenance of equipment and furniture, as well as trucking, hauling, janitorial, security, and related or analogous services, as well as procurement of materials and supplies provided by the Procuring Entity for such services. The term “related” or “analogous services” shall include, but is not limited to, lease or purchase of office space, media advertisements, health maintenance services, and other services essential to the operation of the Procuring Entity. (2016 revised IRR, Section 5[r])

GOP – Government of the Philippines.

GPPB – Government Procurement Policy Board.

INCOTERMS – International Commercial Terms.

Infrastructure Projects – Include the construction, improvement, rehabilitation, demolition, repair, restoration or maintenance of roads and bridges, railways, airports, seaports, communication facilities, civil works components of information technology projects, irrigation, flood control and drainage, water supply, sanitation, sewerage and solid waste management systems, shore protection, energy/power and electrification facilities, national buildings, school buildings, hospital buildings, and other related construction projects of the government. Also referred to as *civil works or works*. (2016 revised IRR, Section 5[u])

LGUs – Local Government Units.

NFCC – Net Financial Contracting Capacity.

NGA – National Government Agency.

PhilGEPS - Philippine Government Electronic Procurement System.

Procurement Project – refers to a specific or identified procurement covering goods, infrastructure project or consulting services. A Procurement Project shall be described, detailed, and scheduled in the Project Procurement Management Plan prepared by the agency which shall be consolidated in the procuring entity's Annual Procurement Plan. (GPPB Circular No. 06-2019 dated 17 July 2019)

PSA – Philippine Statistics Authority.

SEC – Securities and Exchange Commission.

SLCC – Single Largest Completed Contract.

SSS – Social Security System

Supplier – refers to a citizen, or any corporate body or commercial company duly organized and registered under the laws where it is established, habitually established in business and engaged in the manufacture or sale of the merchandise or performance of the general services covered by his bid. (Item 3.8 of GPPB Resolution No. 13-2019, dated 23 May 2019). Supplier as used in these Bidding Documents may likewise refer to a distributor, manufacturer, contractor, or consultant.

UN – United Nations.

Section I. Invitation to Bid

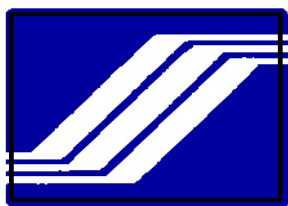

REPUBLIC OF THE PHILIPPINES
SOCIAL SECURITY SYSTEM
 East Avenue, Diliman, Quezon City
 Tel. Nos. (632)8709-7198*(632)8920-6446

E-mail: member_relations@sss.gov.ph*Website <http://www.sss.gov.ph>

Invitation to Bid
ITB-SSS-Goods-2022-089

**SUPPLY, DELIVERY AND INSTALLATION OF MODULAR OFFICE SYSTEM
 AND FURNITURE FOR VARIOUS SSS BRANCH OFFICES**

Approved Budget for the Contract (ABC) & Source of Fund	Delivery/ Completion Period	Price of Bid Documents (non- refundable)	Schedule of Activities Date/Time	
			Pre-bid Conference	Deadline of submission and receipt of bids
<p>₱55,174,061.96</p> <p>Breakdown as follows;</p> <p>Lot I: NCR and Nearby Luzon Branches (SSS Malabon, Pasay-CCP Complex, Marikina, Tagaytay and Rosario-EPZA) – ₱21,526,973.24</p> <p>Lot II: Luzon Branches (SSS Vigan, Baler, San Pedro, Tuguegarao and Tabaco) – ₱14,294,944.16</p> <p>Lot III: VisMin Branches (SSS Valencia, Bislig, Danao, Zamboanga, Bago and Sagay) – ₱19,352,144.56</p> <p>Approved 2022 Corporate Operating Budget – Capital Outlay included in the APP Update for the month of September (1st Update) with Code PAP 2022-343A Annual Procurement Plan (APP)</p>	Ninety (90) calendar days from receipt of Notice to Proceed and Signed Contract	<p>₱13,500.00</p> <p>₱11,500.00</p> <p>₱12,500.00</p>	<p>November 03, 2022 (Thursday) 2:30 p.m.</p>	<p>November 24, 2022 (Thursday) 2:00 p.m.</p>

1. The **SOCIAL SECURITY SYSTEM** now invites Bids for the above item. Delivery of the Goods is required within the period specified above. **Bidders should have completed within three (3) years prior to the date of submission and receipt of bids**, a contract similar to the Project. The description of an eligible Bidder is contained in the Bidding Documents, particularly, in Section II - Instruction to Bidders.
2. Bids received in excess of the ABC shall be automatically rejected at bid opening.
3. Bidding will be conducted through open competitive bidding procedures using a non-discretionary pass/fail criterion as specified in the 2016 Revised Implementing Rules and Regulations (RIRR) of Republic Act 9184 (RA) 9184, otherwise known as the “Government Procurement Reform Act”.

Bidding is restricted to Filipino citizens/sole proprietorships, partnerships, or organizations with at least sixty percent (60%) interest or outstanding capital stock belonging to citizens of the Philippines, and to citizens or organizations of a country the laws or regulations of which grant similar rights or privileges to Filipino citizens, pursuant to RA 5183.

4. Interested bidders may obtain further information from the SSS and inspect the Bidding Documents at the address in the last item of the ITB from Monday to Friday, 8:00 a.m. to 5:00 p.m.

5. A complete set of Bidding Documents may be acquired by interested bidders starting **24 October 2022 up to the scheduled submission & receipt of bids** from the address stated in the last item of the ITB and upon payment of the applicable fee for the Bidding Documents in the amount specified above.

The mode of payment will be on a cash basis payable at the SSS Cash Department, Ground Floor, SSS Main Bldg., upon accomplishment of SSS Form R-6. The Bidding Documents shall be received personally by the prospective Bidder or his authorized representative.

It may also be downloaded free of charge from the website of the Philippine Government Electronic Procurement System (PhilGEPS) and the website of the SSS, provided that Bidders shall pay the applicable fee for the Bidding Documents not later than the submission of their bids.

6. The SSS will hold a Pre-Bid Conference on the date and time specified above at the Bidding Room, 2nd Floor, SSS Main Bldg., East Avenue, Diliman, Quezon City which shall be open to prospective bidders, but attendance shall not be mandatory. To ensure completeness and compliance of bids, bidders are advised to send their authorized technical and/or administrative representatives who will prepare the bid documents.

The Pre-Bid Conference will be conducted through online conference using Microsoft Teams. Kindly e-mail us on or before 02 November 2022, through e-mail address bac@sss.gov.ph, the following:

- a. Name of the representative and e-mail address; and
- b. Technical and administrative queries.

7. Bids must be duly received by the BAC Secretariat at the Bidding Room, 2nd Floor, SSS Main Building, East Avenue, Diliman, Quezon City on the deadline specified above. All Bids must be accompanied by a bid security in any of the acceptable forms and in the amount stated in the ITB Clause 14.

Bid opening shall be on the date and time specified above at the Bidding Room, 2nd Floor, SSS Main Building, East Avenue, Diliman, Quezon City. Bids will be opened in the presence of the bidders' representatives who choose to attend at the address above. Late bids shall not be accepted.

8. References to the dates and times shall be based on Philippine Standard time. Should any of the above dates fall on a holiday, the deadline shall be extended to the same time of the immediately succeeding business day in Quezon City.
9. The SSS reserves the right to reject any and all bids, declare a failure of bidding, or not award the contract at any time prior to contract award in accordance with Sections 35.6 and 41 of the 2016 revised IRR of RA No. 9184, without thereby incurring any liability to the affected bidder or bidders.
10. The SSS assumes no obligation to compensate or indemnify parties for any expense or loss that they may incur as a result of their participation in the procurement process, nor does SSS guarantee that an award will be made as a result of this invitation. Furthermore, the SSS reserves the right to waive any defects or formality in the responses to the eligibility requirements and to this invitation and reserves the right to accept the proposal most advantageous to the agency.

11. For further information, please refer to:

Bids & Awards Committee
The Secretariat
2nd Flr., SSS Main Bldg., East Ave., Diliman, Q.C.
Tel # (632) 8922-1070; (632) 8709-7198 local 5492/6382
Email – bac@sss.gov.ph

12. Bidding Documents may be downloaded from PROCUREMENT tab at www.sss.gov.ph starting **24 October 2022**.

THE CHAIRPERSON
BIDS & AWARDS COMMITTEE

ref.: itb-sss-goods-2022-089-SDI of Various Furniture



Section II. Instructions to Bidders

1. Scope of Bid

The Procuring Entity, *Social Security System* wishes to receive Bids for the Supply, Delivery and Installation of Modular Office System and Furniture for Various SSS Branch Offices, with identification number *ITB-SSS-Goods-2022-089*.

The Procurement Project (referred to herein as “Project”) is composed of *three (3) lots*, the details of which are described in Section VII (Technical Specifications).

2. Funding Information

2.1. The GOP through the source of funding as indicated below for *CY2022* in the amount of Fifty-Five Million One Hundred Seventy-Four Thousand Sixty-One Pesos and Ninety-Six Centavos (P55,174,061.96).

2.2. The source of funding is: Approved 2022 Corporate Operating Budget – Capital Outlay included in the APP Update for the month of September (1st Update) with Code PAP 2022-343A Annual Procurement Plan (APP).

3. Bidding Requirements

The Bidding for the Project shall be governed by all the provisions of RA No. 9184 and its 2016 revised IRR, including its Generic Procurement Manuals and associated policies, rules and regulations as the primary source thereof, while the herein clauses shall serve as the secondary source thereof.

Any amendments made to the IRR and other GPPB issuances shall be applicable only to the ongoing posting, advertisement, or **IB** by the BAC through the issuance of a supplemental or bid bulletin.

The Bidder, by the act of submitting its Bid, shall be deemed to have verified and accepted the general requirements of this Project, including other factors that may affect the cost, duration and execution or implementation of the contract, project, or work and examine all instructions, forms, terms, and project requirements in the Bidding Documents.

4. Corrupt, Fraudulent, Collusive, and Coercive Practices

The Procuring Entity, as well as the Bidders and Suppliers, shall observe the highest standard of ethics during the procurement and execution of the contract. They or through an agent shall not engage in corrupt, fraudulent, collusive, coercive, and obstructive practices defined under Annex “I” of the 2016 revised IRR of RA No. 9184 or other integrity violations in competing for the Project.

5. Eligible Bidders

5.1. Only Bids of Bidders found to be legally, technically, and financially capable will be evaluated.

5.2. Foreign ownership limited to those allowed under the rules may participate in this Project.

5.3. Pursuant to Section 23.4.1.3 of the 2016 revised IRR of RA No.9184, the Bidder shall have an SLCC that is at least one (1) contract similar to the Project the value of which, adjusted to current prices using the PSA’s CPI, must be at least equivalent to:

- a. The Bidder must have completed a single contract that is similar to this Project, equivalent to at least fifty percent (50%) of the ABC.

5.4. The Bidders shall comply with the eligibility criteria under Section 23.4.1 of the 2016 IRR of RA No. 9184.

6. Origin of Goods

There is no restriction on the origin of goods other than those prohibited by a decision of the UN Security Council taken under Chapter VII of the Charter of the UN, subject to Domestic Preference requirements under **ITB** Clause 18.

7. Subcontracts

7.1 The Procuring Entity has prescribed that Subcontracting is not allowed.

8. Pre-Bid Conference

The Procuring Entity will hold a pre-bid conference for this Project on the specified date and time and either at its physical address **Bidding Room, 2nd Floor, SSS Main Bldg., East Avenue, Diliman, Quezon City** and/or through online conference using **Microsoft Teams** as indicated in paragraph 6 of the **IB**.

9. Clarification and Amendment of Bidding Documents

Prospective bidders may request for clarification on and/or interpretation of any part of the Bidding Documents. Such requests must be in writing and received by the Procuring Entity, either at its given address or through electronic mail indicated in the **IB**, at least ten (10) calendar days before the deadline set for the submission and receipt of Bids.

10. Documents comprising the Bid: Eligibility and Technical Components

10.1. The first envelope shall contain the eligibility and technical documents of the Bid as specified in **Section VIII (Checklist of Technical and Financial Documents)**.

10.2. The Bidder's SLCC as indicated in **ITB** Clause 5.3 should have been completed within *the last three (3) years* prior to the deadline for the submission and receipt of bids.

10.3. If the eligibility requirements or statements, the bids, and all other documents for submission to the BAC are in foreign language other than English, it must be accompanied by a translation in English, which shall be authenticated by the appropriate Philippine foreign service establishment, post, or the equivalent office having jurisdiction over the foreign bidder's affairs in the Philippines. Similar to the required authentication above, for Contracting Parties to the Apostille Convention, only the translated documents shall be authenticated through an apostille pursuant to GPPB Resolution No. 13-2019 dated 23 May 2019. The English translation shall govern, for purposes of interpretation of the bid.

11. Documents comprising the Bid: Financial Component

11.1. The second bid envelope shall contain the financial documents for the Bid as specified in **Section VIII (Checklist of Technical and Financial Documents)**.

- 11.2. If the Bidder claims preference as a Domestic Bidder or Domestic Entity, a certification issued by DTI shall be provided by the Bidder in accordance with Section 43.1.3 of the 2016 revised IRR of RA No. 9184.
- 11.3. Any bid exceeding the ABC indicated in paragraph 1 of the **IB** shall not be accepted.
- 11.4. For Foreign-funded Procurement, a ceiling may be applied to bid prices provided the conditions are met under Section 31.2 of the 2016 revised IRR of RA No. 9184.

12. Bid Prices

- 12.1. Prices indicated on the Price Schedule shall be entered separately in the following manner:
 - a. For Goods offered from within the Procuring Entity's country:
 - i. The price of the Goods quoted EXW (ex-works, ex-factory, ex-warehouse, ex-showroom, or off-the-shelf, as applicable);
 - ii. The cost of all customs duties and sales and other taxes already paid or payable;
 - iii. The cost of transportation, insurance, and other costs incidental to delivery of the Goods to their final destination; and
 - iv. The price of other (incidental) services, if any, listed in the **BDS**.
 - b. For Goods offered from abroad:
 - i. Unless otherwise stated in the **BDS**, the price of the Goods shall be quoted delivered duty paid (DDP) with the place of destination in the Philippines as specified in the **BDS**. In quoting the price, the Bidder shall be free to use transportation through carriers registered in any eligible country. Similarly, the Bidder may obtain insurance services from any eligible source country.
 - ii. The price of other (incidental) services, if any, as listed in the **BDS**.

13. Bid and Payment Currencies

- 13.1. For Goods that the Bidder will supply from outside the Philippines, the bid prices may be quoted in the local currency or tradeable currency accepted by the BSP at the discretion of the Bidder. However, for purposes of bid evaluation, Bids denominated in foreign currencies, shall be converted to Philippine currency based on the exchange rate as published in the BSP reference rate bulletin on the day of the bid opening.
- 13.2. Payment of the contract price shall be made in Philippine Pesos.

14. Bid Security

- 14.1. The Bidder shall submit a Bid Securing Declaration or any form of Bid Security in the amount indicated in the **BDS**, which shall be not less than the percentage of the ABC in accordance with the schedule in the **BDS**.

- 14.2. The Bid and bid security shall be valid for *One Hundred Twenty (120) Calendar Days from the Date of the Bid Opening.* Any Bid not accompanied by an acceptable bid security shall be rejected by the Procuring Entity as non-responsive.

15. Sealing and Marking of Bids

Each Bidder shall submit one copy of the first and second components of its Bid.

The Procuring Entity may request additional hard copies and/or electronic copies of the Bid. However, failure of the Bidders to comply with the said request shall not be a ground for disqualification.

If the Procuring Entity allows the submission of bids through online submission or any other electronic means, the Bidder shall submit an electronic copy of its Bid, which must be digitally signed. An electronic copy that cannot be opened or is corrupted shall be considered non-responsive and, thus, automatically disqualified.

16. Deadline for Submission of Bids

- 16.1. The Bidders shall submit on the specified date and time and either at its physical address or through online submission as indicated in paragraph 7 of the **IB**.

17. Opening and Preliminary Examination of Bids

- 17.1. The BAC shall open the Bids in public at the time, on the date, and at the place specified in paragraph 7 of the **IB**. The Bidders' representatives who are present shall sign a register evidencing their attendance. In case videoconferencing, webcasting or other similar technologies will be used, attendance of participants shall likewise be recorded by the BAC Secretariat.

In case the Bids cannot be opened as scheduled due to justifiable reasons, the rescheduling requirements under Section 29 of the 2016 revised IRR of RA No. 9184 shall prevail.

- 17.2. The preliminary examination of bids shall be governed by Section 30 of the 2016 revised IRR of RA No. 9184.

18. Domestic Preference

- 18.1. The Procuring Entity will grant a margin of preference for the purpose of comparison of Bids in accordance with Section 43.1.2 of the 2016 revised IRR of RA No. 9184.

19. Detailed Evaluation and Comparison of Bids

- 19.1. The Procuring BAC shall immediately conduct a detailed evaluation of all Bids rated "*passed*," using non-discretionary pass/fail criteria. The BAC shall consider the conditions in the evaluation of Bids under Section 32.2 of the 2016 revised IRR of RA No. 9184.

- 19.2. If the Project allows partial bids, bidders may submit a proposal on any of the lots or items, and evaluation will be undertaken on a per lot or item basis, as the case maybe. In this case, the Bid Security as required by **ITB** Clause 14 shall be submitted for each lot or item separately.

- 19.3. The descriptions of the lots or items shall be indicated in **Section VII (Technical Specifications)**, although the ABCs of these lots or items are indicated in the **BDS** for purposes of the NFCC computation pursuant to Section 23.4.2.6 of the 2016 revised IRR of RA No. 9184. The NFCC must be sufficient for the total of the ABCs for all the lots or items participated in by the prospective Bidder.
- 19.4. The Project shall be awarded as follows:
- One Project having several items grouped into several lots, which shall be awarded as separate contracts per lot.
- 19.5. Except for bidders submitting a committed Line of Credit from a Universal or Commercial Bank in lieu of its NFCC computation, all Bids must include the NFCC computation pursuant to Section 23.4.1.4 of the 2016 revised IRR of RA No. 9184, which must be sufficient for the total of the ABCs for all the lots or items participated in by the prospective Bidder. For bidders submitting the committed Line of Credit, it must be at least equal to ten percent (10%) of the ABCs for all the lots or items participated in by the prospective Bidder.

20. Post-Qualification

- 20.1 *[Include if Framework Agreement will be used:]* For multi-year Framework Agreement, all bidders initially determined to be eligible and financially compliant shall be subject to initial post-qualification. The BAC shall then recommend the execution of a Framework Agreement among all eligible, technically and financially compliant bidders and the Procuring Entity and shall be issued by HoPE a Notice to Execute Framework Agreement. The determination of the Lowest Calculated Bid (LCB) shall not be performed by the BAC until a Mini-Competition is conducted among the bidders who executed a Framework Agreement. When a Call for Mini-Competition is made, the BAC shall allow the bidders to submit their best financial proposals on such pre-scheduled date, time and place to determine the bidder with the LCB.
- 20.2. Within a non-extendible period of five (5) calendar days from receipt by the Bidder of the notice from the BAC that it submitted the Lowest Calculated Bid, the Bidder shall submit its latest income and business tax returns filed and paid through the BIR Electronic Filing and Payment System (eFPS) and other appropriate licenses and permits required by law and stated in the **BDS**.

21. Signing of the Contract

- 21.1. The documents required in Section 37.2 of the 2016 revised IRR of RA No. 9184 shall form part of the Contract. Additional Contract documents are indicated in the **BDS**.

Section III. Bid Data Sheet

Bid Data Sheet

ITB Clause									
5.3	<p>For this purpose, contracts similar to the Project shall be:</p> <ol style="list-style-type: none"> a. Supply, Delivery and Installation of Modular Office System and Furniture. b. Completed within three (3) years prior to the deadline for the submission and receipt of bids. 								
7.1	Not applicable.								
12	The price of the Goods shall be quoted DDP according to the project sites indicated in Section VI (Schedule of Requirements).								
14.1	<p>The bid security shall be in the form of a Bid Securing Declaration, or any of the following forms and amounts:</p> <table border="1" style="margin-left: auto; margin-right: auto; border-collapse: collapse;"> <thead> <tr> <th style="width: 60%; text-align: center;">Form of Bid Security</th> <th style="text-align: center;">Amount of Bid Security (Not less than the Percentage of the ABC)</th> </tr> </thead> <tbody> <tr> <td style="padding: 5px;">Cash or cashier's/manager's check issued by a Universal or Commercial Bank.</td> <td style="text-align: center; vertical-align: middle;"> Two percent (2%) or Lot I – Php 430,539.46 Lot II – Php 285,898.88 Lot III – Php 387,042.89 </td> </tr> <tr> <td style="padding: 5px;">Bank draft/guarantee or irrevocable letter of credit issued by a Universal or Commercial Bank: Provided, however, that it shall be confirmed or authenticated by a Universal or Commercial Bank, if issued by a foreign bank.</td> <td style="text-align: center; vertical-align: middle;"> Two percent (2%) or Lot I – Php 430,539.46 Lot II – Php 285,898.88 Lot III – Php 387,042.89 </td> </tr> <tr> <td style="padding: 5px;">Surety bond callable upon demand issued by a surety or insurance company duly certified by the Insurance Commission as authorized to issue such security.</td> <td style="text-align: center; vertical-align: middle;"> Five percent (5%) or Lot I – Php 1,076,348.66 Lot II – Php 714,747.21 Lot III – Php 967,607.23 </td> </tr> </tbody> </table> <p>*Bank issued securities must be issued by a universal/commercial bank. *Surety Bonds must be accompanied by a certification from Insurance Commission that issuer is authorized to issue such security. *Bid Securing Declaration must be notarized by a duly commissioned Notary Public.</p>	Form of Bid Security	Amount of Bid Security (Not less than the Percentage of the ABC)	Cash or cashier's/manager's check issued by a Universal or Commercial Bank.	Two percent (2%) or Lot I – Php 430,539.46 Lot II – Php 285,898.88 Lot III – Php 387,042.89	Bank draft/guarantee or irrevocable letter of credit issued by a Universal or Commercial Bank: Provided, however, that it shall be confirmed or authenticated by a Universal or Commercial Bank, if issued by a foreign bank.	Two percent (2%) or Lot I – Php 430,539.46 Lot II – Php 285,898.88 Lot III – Php 387,042.89	Surety bond callable upon demand issued by a surety or insurance company duly certified by the Insurance Commission as authorized to issue such security.	Five percent (5%) or Lot I – Php 1,076,348.66 Lot II – Php 714,747.21 Lot III – Php 967,607.23
Form of Bid Security	Amount of Bid Security (Not less than the Percentage of the ABC)								
Cash or cashier's/manager's check issued by a Universal or Commercial Bank.	Two percent (2%) or Lot I – Php 430,539.46 Lot II – Php 285,898.88 Lot III – Php 387,042.89								
Bank draft/guarantee or irrevocable letter of credit issued by a Universal or Commercial Bank: Provided, however, that it shall be confirmed or authenticated by a Universal or Commercial Bank, if issued by a foreign bank.	Two percent (2%) or Lot I – Php 430,539.46 Lot II – Php 285,898.88 Lot III – Php 387,042.89								
Surety bond callable upon demand issued by a surety or insurance company duly certified by the Insurance Commission as authorized to issue such security.	Five percent (5%) or Lot I – Php 1,076,348.66 Lot II – Php 714,747.21 Lot III – Php 967,607.23								
19.3	<p>The ABC are:</p> <table border="1" style="margin-left: auto; margin-right: auto; border-collapse: collapse;"> <thead> <tr> <th style="width: 15%; text-align: center;">Lot No.</th> <th style="text-align: center;">Amount of ABC</th> </tr> </thead> <tbody> <tr> <td style="text-align: center;">I</td> <td style="text-align: right;">₱ 21,526,973.24</td> </tr> <tr> <td style="text-align: center;">II</td> <td style="text-align: right;">₱ 14,294,944.16</td> </tr> <tr> <td style="text-align: center;">III</td> <td style="text-align: right;">₱ 19,352,144.56</td> </tr> </tbody> </table> <p>Any bid with a financial component exceeding the amount per branch per lot shall not be accepted. (See Summary of Cost Proposal for breakdown)</p>	Lot No.	Amount of ABC	I	₱ 21,526,973.24	II	₱ 14,294,944.16	III	₱ 19,352,144.56
Lot No.	Amount of ABC								
I	₱ 21,526,973.24								
II	₱ 14,294,944.16								
III	₱ 19,352,144.56								
20.2	<p>The Lowest Calculated Bidder shall submit the following:</p> <ol style="list-style-type: none"> 1. Registration certificate from Securities and Exchange Commission (SEC) for corporation including Articles of Incorporation and General Information Sheet (GIS), Department of Trade and Industry (DTI) for sole proprietorship, or 								

	<p>Cooperative Development Authority (CDA) for cooperatives or its equivalent document.</p> <ol style="list-style-type: none"> 2. Mayor's or Business permit issued by the city or municipality where the principal place of business of the prospective bidder is located, or the equivalent document for Exclusive Economic Zones or Areas; 3. Tax clearance per E.O. No. 398, s. 2005, as finally reviewed and approved by the Bureau of Internal Revenue (BIR) 4. Latest Audited Financial Statements 5. Latest income tax return corresponding to the Audited Financial Statements submitted, filed electronically (EFPS); 6. Quarterly VAT (business tax returns) per Revenue Regulations 3-2005 for the last six (6) months prior to submission and opening of bids filed electronically (EFPS);
21.1	Not Applicable

Section IV. General Conditions of Contract

1. **Scope of Contract**

This Contract shall include all such items, although not specifically mentioned, that can be reasonably inferred as being required for its completion as if such items were expressly mentioned herein. All the provisions of RA No. 9184 and its 2016 revised IRR, including the Generic Procurement Manual, and associated issuances, constitute the primary source for the terms and conditions of the Contract, and thus, applicable in contract implementation. Herein clauses shall serve as the secondary source for the terms and conditions of the Contract.

This is without prejudice to Sections 74.1 and 74.2 of the 2016 revised IRR of RA No. 9184 allowing the GPPB to amend the IRR, which shall be applied to all procurement activities, the advertisement, posting, or invitation of which were issued after the effectivity of the said amendment.

Additional requirements for the completion of this Contract shall be provided in the **Special Conditions of Contract (SCC)**.

2. **Advance Payment and Terms of Payment**

2.1. Advance payment of the contract amount is provided under Annex "D" of the revised 2016 IRR of RA No. 9184.

2.2. The Procuring Entity is allowed to determine the terms of payment on the partial or staggered delivery of the Goods procured, provided such partial payment shall correspond to the value of the goods delivered and accepted in accordance with prevailing accounting and auditing rules and regulations. The terms of payment are indicated in the **SCC**.

3. **Performance Security**

Within ten (10) calendar days from receipt of the Notice of Award by the Bidder from the Procuring Entity but in no case later than the signing of the Contract by both parties, the successful Bidder shall furnish the performance security in any of the forms prescribed in Section 39 of the 2016 revised IRR of RA No. 9184.

4. **Inspection and Tests**

The Procuring Entity or its representative shall have the right to inspect and/or to test the Goods to confirm their conformity to the Project specifications at no extra cost to the Procuring Entity in accordance with the Generic Procurement Manual. In addition to tests in the **SCC, Section VII (Technical Specifications)** shall specify what inspections and/or tests the Procuring Entity requires, and where they are to be conducted. The Procuring Entity shall notify the Supplier in writing, in a timely manner, of the identity of any representatives retained for these purposes.

All reasonable facilities and assistance for the inspection and testing of Goods, including access to drawings and production data, shall be provided by the Supplier to the authorized inspectors at no charge to the Procuring Entity.

5. **Warranty**

5.1 In order to assure that manufacturing defects shall be corrected by the Supplier, a warranty shall be required from the Supplier as provided under Section 62.1 of the 2016 revised IRR of RA No. 9184.

5.2 The Procuring Entity shall promptly notify the Supplier in writing of any claims arising under this warranty. Upon receipt of such notice, the Supplier shall, repair or replace the defective Goods or parts thereof without cost to the Procuring Entity, pursuant to the Generic Procurement Manual.

6. Liability of the Supplier

The Supplier's liability under this Contract shall be as provided by the laws of the Republic of the Philippines.

If the Supplier is a joint venture, all partners to the joint venture shall be jointly and severally liable to the Procuring Entity.

Section V. Special Conditions of Contract

Special Conditions of Contract

GCC Clause	
1	<p>The Supplier/Bidder must have a fabrication plant in the Philippines with the following facilities and equipment:</p> <ol style="list-style-type: none"> 1. Raw materials warehousing 2. Cutting Area 3. Machines (edging, drilling and shaping) 4. Assembly Area <p>The Supplier must provide certification or proof of personnel's training on installation/dismantling including proper handling of office system furniture.</p> <p>All office chairs must have a certificate (e.g., American National Standards Institute, Business, and Institutional Furniture Manufacturers Association, or Leadership for Energy and Environmental Design) that it passed the standards on safety, durability, and structural adequacy.</p> <p>The Supplier/winning Bidder shall complete the delivery and installation of goods within 90 calendar days from the date of receipt of Purchase Order/ Notice to Proceed.</p> <p>Warranty Certificate shall be issued in favor of the Social Security System covering the furniture/fixtures delivered.</p> <p>Replacement of defective furniture/fixtures and materials to be used for repair jobs within the duration of the warranty.</p> <p>The Supplier further warrants that all Goods supplied under this Contract shall have no defect, arising from design, materials, or workmanship or from any act or omission of the Supplier that may develop under normal use of the supplied Goods in the conditions prevailing in the country of final destination.</p> <p>Supplier shall be responsible for all the cost related to the warranty period.</p> <p>Supplier should provide spare parts as needed within the warranty period.</p> <p>Delivery and Documents –</p> <p>For purposes of the Contract, “EXW,” “FOB,” “FCA,” “CIF,” “CIP,” “DDP” and other trade terms used to describe the obligations of the parties shall have the meanings assigned to them by the current edition of INCOTERMS published by the International Chamber of Commerce, Paris. The Delivery terms of this Contract shall be as follows:</p> <p>The delivery terms applicable to this Contract are delivered to SSS Branches (refer to Section VI. Schedule of Requirements).</p> <p>Delivery of the Goods shall be made by the Supplier in accordance with the terms specified in Section VI. Schedule of Requirements.</p> <p>For purposes of this Clause the Procuring Entity's Representative at the Project Site is a representative from Branch Expansion and Management Services Department.</p> <p>Incidental Services –</p> <p>The Supplier is required to provide all of the following services, including additional services, if any, specified in Section VI. Schedule of Requirements:</p>



	<ul style="list-style-type: none"> a. performance or supervision of on-site assembly and/or start-up of the supplied Goods; b. furnishing of tools required for assembly and/or maintenance of the supplied Goods; d. performance or supervision or maintenance and/or repair of the supplied Goods, for a period of time agreed by the parties, provided that this service shall not relieve the Supplier of any warranty obligations under this Contract; <p>The Contract price for the Goods shall include the prices charged by the Supplier for incidental services and shall not exceed the prevailing rates charged to other parties by the Supplier for similar services.</p> <p>Packaging –</p> <p>The Supplier shall provide such packaging of the Goods as is required to prevent their damage or deterioration during transit to their final destination, as indicated in this Contract. The packaging shall be sufficient to withstand, without limitation, rough handling during transit and exposure to extreme temperatures, salt and precipitation during transit, and open storage. Packaging case size and weights shall take into consideration, where appropriate, the remoteness of the Goods’ final destination and the absence of heavy handling facilities at all points in transit.</p> <p>Transportation –</p> <p>Where the Supplier is required under Contract to deliver the Goods CIF, CIP, or DDP, transport of the Goods to the port of destination or such other named place of destination in the Philippines, as shall be specified in this Contract, shall be arranged and paid for by the Supplier, and the cost thereof shall be included in the Contract Price.</p> <p>Where the Supplier is required under this Contract to transport the Goods to a specified place of destination within the Philippines, defined as the Project Site, transport to such place of destination in the Philippines, including insurance and storage, as shall be specified in this Contract, shall be arranged by the Supplier, and related costs shall be included in the contract price.</p> <p>Where the Supplier is required under Contract to deliver the Goods CIF, CIP or DDP, Goods are to be transported on carriers of Philippine registry. In the event that no carrier of Philippine registry is available, Goods may be shipped by a carrier which is not of Philippine registry provided that the Supplier obtains and presents to the Procuring Entity certification to this effect from the nearest Philippine consulate to the port of dispatch. In the event that carriers of Philippine registry are available but their schedule delays the Supplier in its performance of this Contract the period from when the Goods were first ready for shipment and the actual date of shipment the period of delay will be considered force majeure.</p> <p>The Procuring Entity accepts no liability for the damage of Goods during transit other than those prescribed by INCOTERMS for DDP deliveries. In the case of Goods supplied from within the Philippines or supplied by domestic Suppliers risk and title will not be deemed to have passed to the Procuring Entity until their receipt and final acceptance at the final destination.</p>
2.2	<p>Payment shall be made upon 100% completion of the delivery and installation of furniture “per branch” and upon submission and issuance of the following documents which shall be credited to the LANDBANK or DBP or any choice of bank account subject to applicable bank charges of the winning bidder:</p> <ul style="list-style-type: none"> a. Original copy of Delivery Receipt and Sales Invoice

	<p>b. Certificate of Final Acceptance from BEMSD c. Inspection and Acceptance Report from Branches d. Property Accountability Receipt (PAR) from Office Services Department</p> <p>The payment shall be subject to retention of Withholding Tax and other applicable taxes in accordance with existing Laws and BIR Rules and Regulations, to be remitted directly to the BIR by the SSS.</p> <p>Payment using Letter of Credit is not allowed.</p>
4	<p>The inspections and tests that will be conducted is:</p> <p>During Post-qualification, the designated TWG will conduct onsite inspection on the facilities of the LCB or SCB to ensure that they have the capacity and equipment/facility to produce/provide the required number of items within the timeline and delivery sites provided.</p> <p>Bidder must install and present mock-up samples (for chairs and cabinets only) during the post-qualification stage to ensure its compliance with the technical specifications.</p>
5.1	<p>Three (3) years after acceptance by the Procuring Entity of the delivered goods.</p>
5.2	<p>The period for correction of defects in the warranty period shall be done after notification of defect was first communicated (verbally or in writing) by SSS to the Supplier as follows:</p> <p>NCR Branches.....within seven (7) working days</p> <p>Luzon Branches.....within fifteen (15) working days</p> <p>Visayas and Mindanao Branches.....within twenty-one (21) working days</p>
6	<p>Liability of the Supplier</p> <p>1. CONFIDENTIALITY. Neither party shall, without the prior written consent of the other, disclose or make available to any person, make public, or use directly or indirectly, except for the performance and implementation of the works, any confidential information, acquired from an information holder in connection with the performance of this Contract, unless: (i) the information is known to the disclosing party, as evidenced by its written records, prior to obtaining the same from the information holder and is not otherwise subject to disclosure restrictions on the disclosing party, (ii) the information is disclosed to the disclosing party by a third party who did not receive the same, directly or indirectly, from an information holder, and who has no obligation of secrecy with respect thereto, or (iii) required to be disclosed by law.</p> <p>The obligation of confidentiality by both parties, as provided herein, shall survive the termination of the Agreement.</p> <p>2. MERGER AND CONSOLIDATION. In case of merger, consolidation or change of ownership of the SUPPLIER with other company, it is the responsibility of the surviving company/consolidated company/acquiring entity to inform SSS of the change in corporate structure/ownership. Failure to do so shall translate in such company assuming all liabilities of the acquired/merged company under the Agreement.</p> <p>3. FORCE MAJEURE. SUPPLIER shall not be liable for forfeiture of its performance security, liquidated damages, or termination for default if and to the extent that SUPPLIER's delay in performance or other failure to perform its obligations under this Agreement is the result of a force majeure.</p>



For purposes of this Agreement the terms "force majeure" and "fortuitous event" may be used interchangeably. In this regard, a fortuitous event or force majeure shall be interpreted to mean an event which SUPPLIER could not have foreseen, or which though foreseen, was inevitable. It shall not include ordinary unfavorable weather conditions; and any other cause the effects of which could have been avoided with the exercise of reasonable diligence by SUPPLIER. Such events may include, but not limited to, acts of SSS in its sovereign capacity, wars or revolutions, fires, floods, epidemics, quarantine restrictions, and freight embargoes.

If a force majeure situation arises, SUPPLIER shall promptly notify SSS in writing of such condition and the cause thereof. Unless otherwise directed by SSS in writing, SUPPLIER shall continue to perform its obligations under this Agreement as far as is reasonably practical and shall seek all reasonable alternative means for performance not prevented by the force majeure.

4. **NON-ASSIGNMENT.** SUPPLIER shall not assign its rights or obligations under this Agreement, in whole or in part, except with SSS's prior written consent. SUPPLIER shall not subcontract in whole or in part the PROJECT and deliverables subject of this Agreement without the written consent of SSS.
5. **WAIVER.** Failure by either party to insist upon the other strict performance of any of the terms and conditions hereof shall not be deemed a relinquishment or waiver of any subsequent breach or default of the terms and conditions hereof, which can only be deemed made if expressed in writing and signed by its duly authorized representative. No such waiver shall be construed as modification of any of the provisions of the Agreement or as a waiver of any past or future default or breach hereof, except as expressly stated in such waiver.
6. **CUMULATIVE REMEDIES.** Any and all remedies granted to the parties under the applicable laws and the Contract shall be deemed cumulative and may therefore, at the sole option and discretion, be availed of by the aggrieved party simultaneously, successively, or independently.
7. **NO EMPLOYER-EMPLOYEE RELATIONSHIP.** It is expressly and manifestly understood and agreed upon that the employees of SUPPLIER assigned to perform the PROJECT are not employees of SSS. Neither is there an employer-employee relationship between SSS and SUPPLIER.

The Agreement does not create an employer-employee relationship between SSS and the SUPPLIER including its personnel; that the services rendered by the personnel assigned by SUPPLIER to SSS in the performance of its obligation under the contract do not represent government service and will not be credited as such; that its personnel assigned to SSS are not entitled to benefits enjoyed by SSS' officials and employees such as Personal Economic Relief Allowance (PERA), Representation and Transportation Allowance (RATA), ACA, etc.; that these personnel are not related within the third degree of consanguinity or affinity to the contracting officer and appointing authority of SSS; that they have not been previously dismissed from the government service by reason of an administrative case; that they have not reached the compulsory retirement age of sixty-five (65); and that they possess the education, experience and skills required to perform the job. The SUPPLIER hereby acknowledges that no authority has been given by SSS to hire any person as an employee of the latter. Any instruction given by SSS or any of its personnel to SUPPLIER's employees are to be construed merely as a measure taken by the former to ensure and enhance the quality of project performed hereunder. The SUPPLIER shall, at all times, exercise supervision and control over its employees in the performance of its obligations under the contract.

8. **PARTNERSHIP.** Nothing in the contract shall constitute a partnership between the parties. No party or its agents or employees shall be deemed to be the agent, employee or representative of any other party.
9. **COMPLIANCE WITH SS LAW.** SUPPLIER shall report all its employees to SSS for coverage and their contributions, as well as, all amortizations for salary/education/calamity and other SSS loans shall be updated. Should SUPPLIER fail to comply with its obligations under the provisions of the SS Law and Employees' Compensation Act, SSS shall have the authority to deduct any unpaid SS and EC contributions, salary, educational, emergency and/or calamity loan amortizations, employer's liability for damages, including interests and penalties from SUPPLIER's receivables under this Agreement.

Further, prescription does not run against SSS for its failure to demand SS contributions or payments from SUPPLIER. Moreover, SUPPLIER shall forever hold in trust SS contributions or payments of its employees until the same is fully remitted to SSS.

10. **COMPLIANCE WITH LABOR LAWS.** SUPPLIER, as employer of the personnel assigned to undertake the PROJECT, shall comply with all its obligations under existing laws and their implementing rules and regulations on the payment of minimum wage, overtime pay, and other labor-related benefits as well as remittances or payment of the appropriate amount or contributions/payment (SSS, EC, Pag-IBIG, PhilHealth and taxes) with concerned government agencies/offices.

It is agreed further, that prior to the release of any payment by SSS to SUPPLIER, its President or its duly authorized representative, shall submit a sworn statement that all monies due to all its employees assigned to the PROJECT as well as benefits by law and other related labor legislation have been paid by SUPPLIER and that he/she assumed full responsibility thereof.

11. **COMPLIANCE WITH TAX LAWS.** SUPPLIER shall, in compliance with tax laws, pay the applicable taxes in full and on time and shall regularly present to SSS within the duration of the Contract, tax clearance from the Bureau of Internal Revenue (BIR) as well as copy of its income and business tax returns duly stamped by the BIR and duly validated with the tax payments made thereon. Failure by SUPPLIER to comply with the foregoing shall entitle SSS to suspend payment of the Contract Price.

As required under Executive Order (EO) 398, s. 2005, SUPPLIER shall submit income and business tax returns duly stamped and received by the BIR, before entering and during the duration of this Agreement. SUPPLIER, through its responsible officer, shall also certify under oath that it is free and clear of all tax liabilities to the government. SUPPLIER shall pay taxes in full and on time and that failure to do so will entitle SSS to suspend or terminate this Agreement.

12. **LIQUIDATED DAMAGES.** If SUPPLIER fails to satisfactorily deliver any or all of the Goods and/or to perform the Services within the period(s) specified in the PBD inclusive of duly granted time extensions if any, SSS shall, without prejudice to its other remedies under this Agreement and under the applicable law, deduct from the Contract Price, as liquidated damages, the applicable rate of one tenth (1/10) of one (1) percent of the cost of the unperformed portion for every day of delay until actual delivery or performance. Once the amount of liquidated damages reaches ten percent (10%), SSS may rescind or terminate this Agreement, without prejudice to other courses of action and remedies open to it.

13. **HOLD FREE and HARMLESS.** SUPPLIER agrees to defend, indemnify, and hold SSS free and harmless from any and all claims, damages, expenses, fines, penalties and/or liabilities of whatever nature and kind, whether in law or equity, that may arise by reason of the implementation of the Agreement. In addition, SUPPLIER agrees to indemnify SSS for any damage as a result of said implementation.

SUPPLIER hereby assumes full responsibility for any injury, including death, loss or damage which may be caused to SSS' employees or property or third person due to SUPPLIER's employees' fault or negligence, and further binds itself to hold SSS free and harmless from any of such injury or damage. SSS shall not be responsible for any injury, loss or damage which SUPPLIER or any of its employees may sustain in the performance of SUPPLIER's obligations under this Agreement.

14. **SETTLEMENT OF DISPUTES.** If any dispute or difference of any kind whatsoever shall arise between SSS and SUPPLIER in connection with or arising out of this Agreement, the Parties shall make every effort to resolve amicably such dispute or difference by mutual consultation.

If after thirty (30) days, the Parties have failed to resolve their dispute or difference by such mutual consultation, then either SSS or SUPPLIER may give notice to the other Party of its intention to commence arbitration, in accordance with RA No. 876, otherwise known as the "Arbitration Law" and RA No. 9285, otherwise known as the "Alternative Dispute Resolution Act of 2004," in order to settle their disputes.

No arbitration in respect of this matter may be commenced unless such notice is given.

Notwithstanding any reference to arbitration herein, the Parties shall continue to perform their respective obligations under this Agreement unless they otherwise agree.

15. **VENUE OF ACTIONS.** In the event court action is necessary in order to promote Arbitration, such action shall be filed only before the proper courts of Quezon City, to the exclusion of all other venues.

16. **GOVERNING LAW.** The Agreement shall be governed by and interpreted according to the laws of the Republic of the Philippines.

17. **AMENDMENTS.** This Agreement may be amended only in writing and executed by the parties or their duly authorized representatives.

18. **SEPARABILITY.** If any one or more of the provisions contained in the contract or any document executed in connection herewith shall be invalid, illegal or unenforceable in any respect under any applicable law, then: (i) the validity, legality and enforceability of the remaining provisions contained herein or therein shall not in any way be affected or impaired and shall remain in full force and effect; and (ii) the invalid, illegal or unenforceable provision shall be replaced by the parties immediately with a term or provision that is valid, legal and enforceable and that comes closest to expressing the intention of such invalid illegal or unenforceable term of provision.

19. **BINDING EFFECT.** The Agreement shall be binding upon the Parties hereto, their assignee/s and successor/s-in-interest.

Section VI. Schedule of Requirements

The delivery schedule expressed as weeks/months stipulates hereafter a delivery date which is the date of delivery to the project site.

Item Number	Description	Quantity	Total	Delivered, Weeks/Months
I	Supply, Delivery and Installation of Modular Office System and Furniture for Various SSS Branch Offices			All items in the Contract shall be delivered and/or installed within Ninety (90) calendar days from the receipt of Purchase Order
Lot I	NCR and Nearby Luzon Branches			
1	SSS Malabon Branch 4/F Malabon Citisquare, C-4 Road cor Dagat-dagatan Ave. Longos, Malabon City	1 lot	1 lot	
2	SSS Pasay-CCP Complex Branch Seascape Villagem, Atang dela Rama cor. Zolio Hilario St., CCP Complex, Brgy. 076, Pasay City	1 lot	1 lot	
3	SSS Marikina Branch 3F Xeland, Gil Fernando Ave., cor Guerilla St., Marikina City	1 lot	1 lot	
4	SSS Tagaytay Branch LGF, Primark Town Center - Tagaytay, Maharlika - East, Tagaytay City	1 lot	1 lot	
5	SSS Rosario-EPZA G/F & 2/F 248 Abutin Building, Tejero Convention, Gen. Trias Drive, Rosario, Cavite	1 lot	1 lot	
Lot II	Luzon Branches			
1	SSS Vigan Branch 2F UNP Town Center, Brgy. Tamag, Vigan City, Ilocos Sur	1 lot	1 lot	
2	SSS Baler Branch 2F NE Pacific Mall Baler, Brgy. Suklayan, Baler, Aurora	1 lot	1 lot	
3	SSS San Pedro Branch 2F Robinsons Galleria South, San Pedro, Laguna	1 lot	1 lot	
4	SSS Tuguegarao Branch 2F Robinsons Place Tuguegarao, Brgy. Tanza, Tuguegarao City	1 lot	1 lot	
5	SSS Tabaco Branch SSS Tabaco, GF - 3F JSPAPIO Building, National Rd., Brgy. Tagas, Tabaco, Albay	1 lot	1 lot	
Lot III	VisMin Branches			
1	SSS Valencia Branch 2F Robinsons Place, Brgy. Bagontaas, Valencia City, Bukidnon	1 lot	1 lot	
2	SSS Bislig Branch Napoles Building, Espiritu St., Mangagoy, Bislig City, Surigao del Sur	1 lot	1 lot	
3	SSS Danao Branch 2F Citymall Danao, Oliver Sr. Ext. cor. F. Ralota St., Poblacion, Danao City, Cebu	1 lot	1 lot	
4	SSS Zamboanga Branch	1 lot	1 lot	

Item Number	Description	Quantity	Total	Delivered, Weeks/Months
	PHIDCO Building, Veterans Ave. Zamboanga City			
5	SSS Bago Branch TOPBRANDS Building, Rizal St., Poblacion, Bago City, Negros Occidental	1 lot	1 lot	
6	SSS Sagay Branch GF Square and Circles Bldg., National Highway, Old Sagay Road, Sagay City, Negros Occidental	1 lot	1 lot	



Section VII. Technical Specifications

Technical Specifications

Item	Specification	Statement of Compliance	Annex
<p><i>Bidders must state here either “Comply” or “Not Comply” against each of the individual parameters of each Specification stating the corresponding performance parameter of the equipment offered. Statements of “Comply” or “Not Comply” must be supported by evidence in a Bidders Bid and cross-referenced to that evidence. Evidence shall be in the form of manufacturer’s un-amended sales literature, unconditional statements of specification and compliance issued by the manufacturer, samples, independent test data etc., as appropriate. A statement that is not supported by evidence or is subsequently found to be contradicted by the evidence presented will render the Bid under evaluation liable for rejection. A statement either in the Bidder's statement of compliance or the supporting evidence that is found to be false either during Bid evaluation, post-qualification or the execution of the Contract may be regarded as fraudulent and render the Bidder or supplier liable for prosecution subject to the applicable laws and issuances.</i></p>			
1.	Modular Office System		
	<ul style="list-style-type: none"> - Submit High Pressure Laminates (HPL) swatches: Formica or WilsonArt Laminates <i>Lincoln Walnut Code “7188”</i> <i>Black Code “0909”</i> <i>Ebony Code “SF 7659”</i> <i>Folkstone Code “0927”</i> - Manufacturer's Certification is required. 		
	<ul style="list-style-type: none"> - Submit Fabric Upholstery swatches: <i>Titch or approved equivalent</i> <i>Titch “Sunrise” or approved equivalent</i> <i>Titch “Expensive Blue” or approved equivalent</i> - Manufacturer's Certification is required. 		
2.	Seating Furniture		
	<ul style="list-style-type: none"> - Plastic shell with high density molded foam. (Uratex or approved equivalent). - Manufacturer's Certification is required. 		
	<ul style="list-style-type: none"> - 28mm diameter gas cylinder head with outer tube diameter of 50 – 60 mm, German Brand gas lift mechanism (Suspa, Stabilus or approved equal) - Manufacturer's Certification is required. 		
	<ul style="list-style-type: none"> - 5-prong metal or nylon base with crisscrossed inner core; load capacity of not less than 250 lbs. - Manufacturer's Certification is required. 		
	<ul style="list-style-type: none"> - Tubular legs in powder-coated finish, cantilever type; load capacity of not less than 250 lbs. - Manufacturer's Certification is required. 		
	<ul style="list-style-type: none"> - Submit Fabric/Leatherette Upholstery swatches: <i>Pantone Blue Fabric</i> <i>Black Leatherette</i> 		
3.	Contract Furniture		



Item	Specification	Statement of Compliance	Annex
	<ul style="list-style-type: none"> - Submit High Pressure Laminates (HPL) swatches: <i>Formica or WilsonArt Laminates Folkstone Code "0927" Navy Blue Code "0969" Natural Maple Code "0756" Lincoln Walnut Code "7188"</i> - Manufacturer's Certification is required. 		
	<ul style="list-style-type: none"> - Submit Synthetic Stone Sample <i>Cobalt Blue</i> - Manufacturer's Certification is required. 		
4.	Steel Shelves, Cabinets and Drawers		
	<p>Open Steel Shelves</p> <ul style="list-style-type: none"> - Vertical Post: <i>Ga.#14 (2.0mm thk.) cold-rolled steel and roll formed into modified angle shape with 38mm x 38mm holes.</i> - Shelves: <i>Fabricated in cold-rolled sheet Ga.#18 (1.27mm thk.) double bended on all sides with bottom support in rectangular form, welded.</i> - Stiffener: <i>Ga.#18 (1.27mm thk.)</i> - Manufacturer's Certification is required. 		
	<p>4-D Lateral Filing Cabinet</p> <ul style="list-style-type: none"> - Pull-out Drawer: <i>Fabricated in cold rolled shell GA.#22 (0.80mm thk.) with 2 steel file divider and built-in PVC flush handle per drawer. Heavy-duty drawer suspension in ball-bearing slides and zinc chromate finish, with a minimum load capacity of 50 kgs./drawer.</i> - Interior Supports/Braces: <i>Ga.#18 (1.20mm thk.) cold-rolled steel.</i> - Carcase/Shell: <i>Fabricated in cold rolled sheet Ga.#20 (0.90mm thk.) with vertical support on both sides, welded.</i> - Rail: <i>Made in heavy-duty cold rolled sheet, Ga.#17 (1.40mm thk.) in full extension suspension on roller bearing in powder-coated finish. With a minimum load capacity of 50kgs./drawer.</i> - Manufacturer's Certification is required. 		
	<p>Mobile Pedestal Drawer</p> <ul style="list-style-type: none"> - Body/Case: <i>Fabricated in cold rolled sheet, Ga.#22 (0.80mm thk.) in powder-coated finish.</i> - Pull-out Drawer: <i>Fabricated in cold rolled sheet, Ga.#24 (0.60mm thk.) with central control lock on the top drawer.</i> - Rail: <i>Made in cold rolled sheet, Ga.#20 (0.90mm thk.), hang on roller bearing in powder-coated finish.</i> - Casters: <i>Lockable caster wheel with fifth wheel for stability.</i> 		

Item	Specification	Statement of Compliance	Annex
	- Manufacturer's Certification is required.		

BRANCH HEAD WORKSTATION (BHW)

DESIGN	Free-standing "D" shape main desk with rectangular side desk; Medium Density Fiber (MDF) board table top in High Pressure Laminate (HPL) finish
CONSTRUCTION	
Main Desk	750mm (W) x 1800mm (L) x 750mm (H)
Worktop	30 mm thick MDF board in high pressure laminate (HPL) finish with 2 mm thick PVC edging and two (2) plastic grommet with rotating cover.
Modesty Panel	25 mm thick MDF board in high pressure laminate (HPL) finish with 2 mm thick PVC edging.
Legs/Support	25mm thick MDF board in high pressure laminate (HPL) finish with 2 mm thick PVC edging and adjustable PVC gliders.
Side Desk Dimension	450 mm(W) x 1200 mm (L) x 750mm (H)
Worktop	30 mm thick MDF board in high pressure laminate (HPL) finish with 2 mm thick PVC edging and plastic grommet with rotating cover.
Legs/Supports	25 mm thick MDF board in high pressure laminate (HPL) finish with 2 mm thick PVC edging and PVC gliders
Modesty Panel	25mm thick MDF board in high pressure laminate (HPL) finish with 2 mm thick PVC edging and PVC gliders.
ACCESSORIES	
Center Drawer w/ Lock	540 mm(W) x 400mm(D) x 95mm(H); Gauge 22 cold rolled steel in powder coated finish and full extension ball-bearing slides; Color: Black
Keyboard Tray	Hard plastic with full extension ball-bearing slides; Color: Black
COLOR/ FINISHES	
High Pressure Laminate (HPL)	Formica or WilsonArt Laminates. <i>Tabletop</i> : Lincoln Walnut code "7188" <i>Legs/Supports</i> : Black code "0909"



ASSISTANT BRANCH HEAD WORKSTATION (ABHW)

DESIGN	L-shaped workstation with 50mm thick Modular Panel in cushioned fabric upholstery with 30mm thick Medium Density Fiber (MDF) board tabletop in High Pressure Laminate (HPL) finish.
CONSTRUCTION	
Worktop	30 mm thick medium density fiber (MDF) board in HPL finish, with 2 mm thick PVC edging and two (2) plastic grommet with rotating cover for every work surfaces. Main Desk :1500 mm (W) x 600 mm (D) x740mm (H) Side Desk : 1200 mm (W) x 450 mm (D) x 740mm (H)
High Partition	1500 mm(H) using 50 mm thick modular panel in Teflon-coated fabric finish in 1/8" thick foam padding with adjustable gliders and quarter glass
Frame, Trim, Capping, and Corner Posts	Aluminum extrusions in powder-coated finish. Submit sample for approval
Skirting/Base	100mm (H) powder-coated aluminum panel with raceway for cables and three (3) knockouts for UPS / Normal Power / Datacom outlets.
COLORS/ FINISHES	Specific colors/finishes subject for approval.
Modular Panel Fabric Upholstery	Two-tone, Titch brand fabric or approved equal. <i>Top:</i> Titch "Sunrise"; <i>Bottom:</i> Titch "Expensive Blue"
High Pressure Laminate (HPL)	Formica or WilsonArt Laminates. <i>Tabletop :</i> Ebony code: "SF 7659"

SECTION HEAD WORKSTATION – (SHW) – varies depending on layout

DESIGN	L-shaped workstation with 50mm thick Modular Panel in cushioned fabric upholstery with 30mm thick Medium Density Fiber (MDF) board tabletop in High Pressure Laminate (HPL) finish.
CONSTRUCTION	
Worktop	30 mm thick medium density fiber (MDF) board in HPL finish, with 2 mm thick PVC edging and two (2) plastic grommet with rotating cover for every work surfaces. Main Desk :1500 mm (W) x 600 mm (D) x740mm (H) Side Desk : 1200 mm (W) x 450 mm (D) x 740mm (H)
High Partition	1500 mm (H) using 50 mm thick modular panel in Teflon-coated fabric finish and 1/8" thick foam padding with adjustable gliders
Frame, Trim, Capping, and Corner Posts	Aluminum Extrusions in powder-coated finish. Submit sample for approval
Skirting/Base	100mm (H) powder-coated aluminum panel with raceway for cables and three (3) knockouts for UPS / Normal Power / Datacom outlets.
COLORS/ FINISHES	Specific colors/finishes subject for approval.
Modular Panel Fabric Upholstery	Two-tone, Titch brand fabric or approved equal. <i>Top:</i> Titch "Sunrise"; <i>Bottom:</i> Titch "Expensive Blue"
High Pressure Laminate (HPL)	Formica or WilsonArt Laminates. <i>Tabletop :</i> Folkstone "0927"

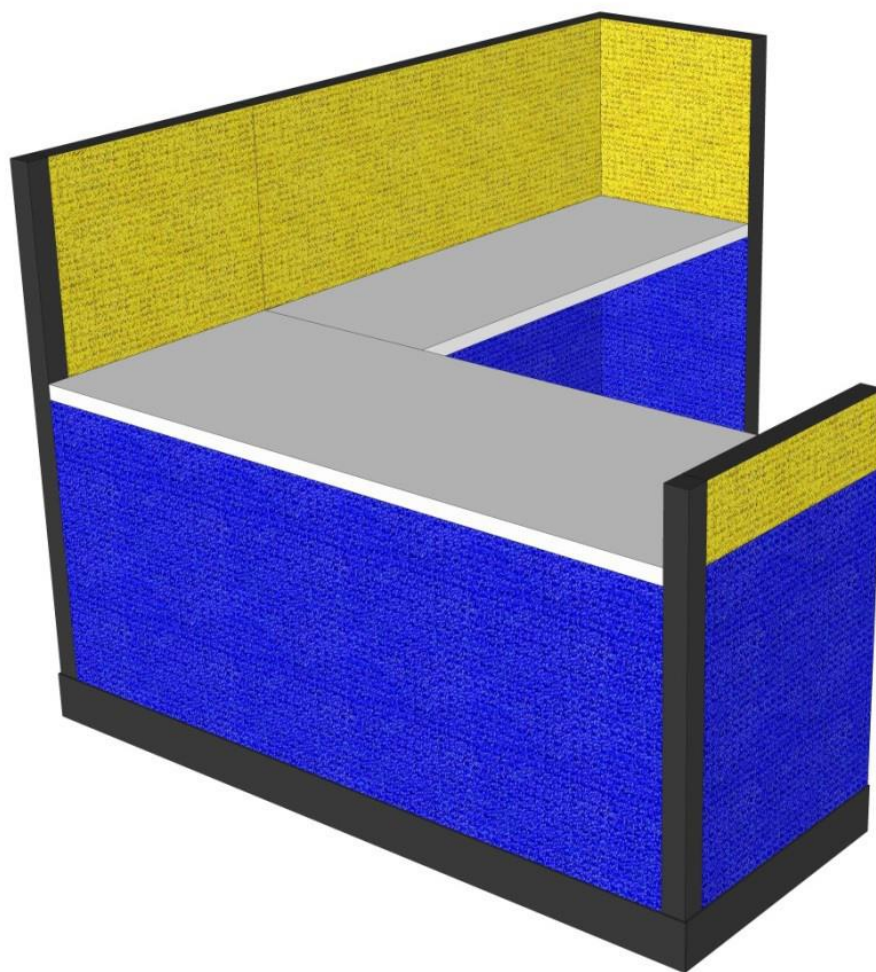

STAFF/CLERICAL WORKSTATION - (SW) – varies depending on layout

DESIGN	Modular workstation with 50 mm thick modular panels in cushioned fabric upholstery with 30mm thick MDF board tabletop in High Pressure Laminate finish.
CONSTRUCTION	
Worktop	1500mm (W) x 600mm (D) x 30mm thick medium density fiber (MDF) board in HPL finish, with 2 mm thick PVC edging and two (2) plastic grommet with rotating cover.
Frame, Trim, Capping, and Corner Posts	Extruded aluminum in powder-coated finish. Submit sample for approval
Modular Panel	50 mm thick modular panel in Teflon-coated fabric finish and 1/8" thick foam padding.
Skirting/Base	100mm (H) powder-coated aluminum panel with raceway for cables and three (3) knockouts for UPS / Normal Power / Datacom outlets.
COLORS/ FINISHES	
Modular Panel Fabric upholstery	Two-tone, Titch brand fabric or approved equal. <i>Top: Titch "Sunrise"</i> <i>Bottom: Titch "Expensive Blue"</i>
High pressure Laminate (HPL)	Formica or WilsonArt Laminates: <i>Tabletop : Folkstone "0927"</i>

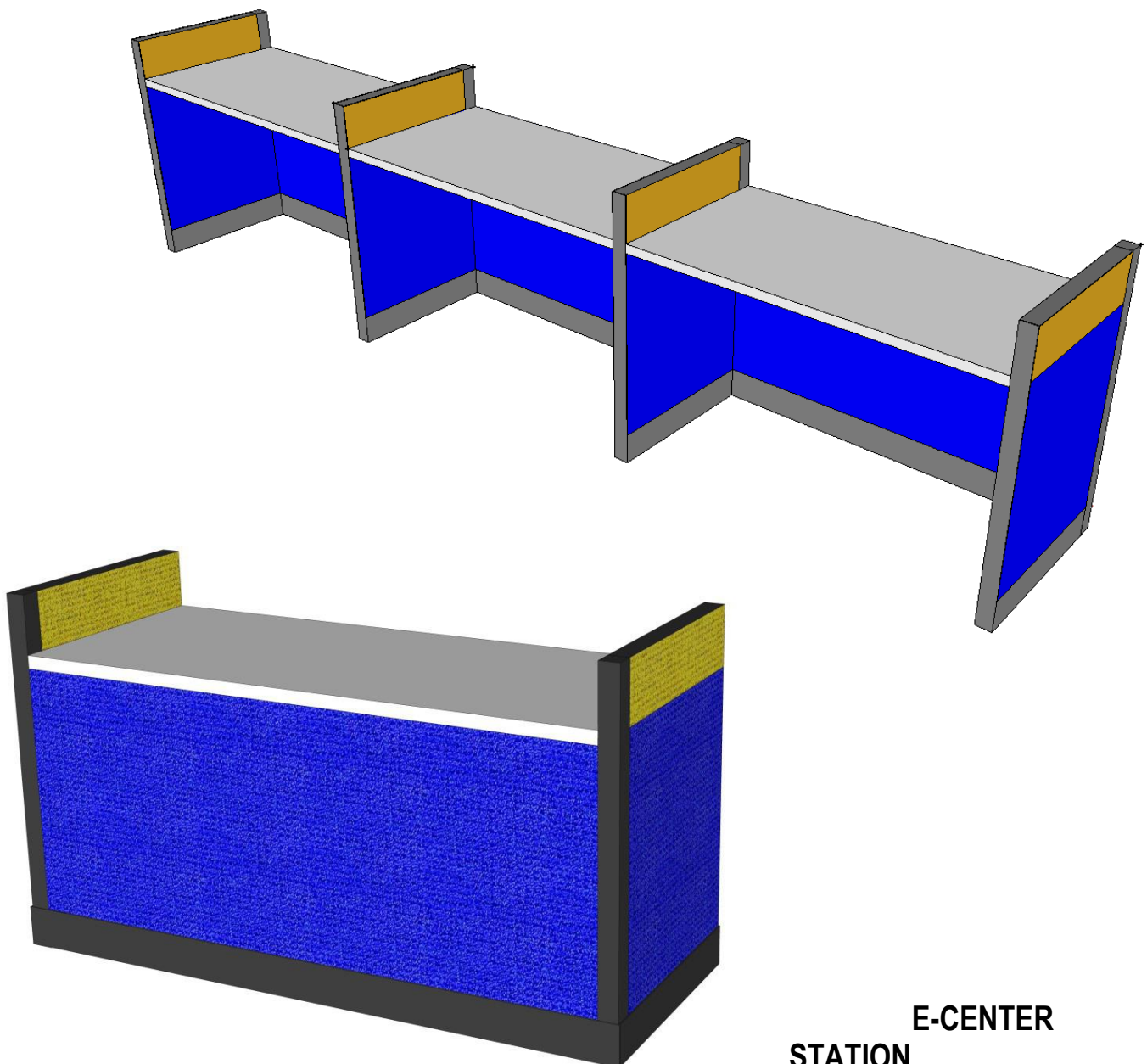

**E-CENTER
STATION**

DESIGN	Modular workstation with 32mm thick particle board panels in High Pressure Laminate (HPL) finish and 30mm thick Medium Density Fiber (MDF) board tabletop in HPL Finish
CONSTRUCTION	
Worktop	700mm (L) x 500mm (W) x 30mm thick Medium Density Fiber (MDF) board in HPL Finish and post-formed edge, with 2mm thick PVC edging and one (1) plastic grommet with rotating cover
Modesty and Side Panel	32mm thick particle board panels in High Pressure Laminate (HPL) finish.
Framing/Capping	Extruded aluminum in powder-coated finish. Color: <i>Submit sample for approval.</i>
Skirting/Base	100mm (H) powder-coated aluminum panel with raceway for cables and three (3) knock-out for UPS, Normal Power and Datacom Outlets.
ACCESSORIES	
CPU Holder	2- $\frac{3}{8}$ x 2 angle bar molded on PC CPU Dimensions fixed and anchored by 4- $\frac{3}{8}$ x $\frac{3}{4}$ wood screw.
Acrylic Plastic Divider	3mm thk white acrylic plastic divider mounted on modular partition using aluminum channel with silicone sealant
Pull Out Drawer for Scanner	700mm (L) x 500mm (W) x 19mm thick Medium Density Fiber (MDF) board in HPL Finish and post-formed edge, with 2mm thick PVC edging
COLOR/ FINISHES	
High Pressure Laminate Finish	Formica or WilsonArt Laminates. <i>Tabletop: Folkstone0927</i> <i>Panel : Expensive Blue and Sunrise Yellow”</i>

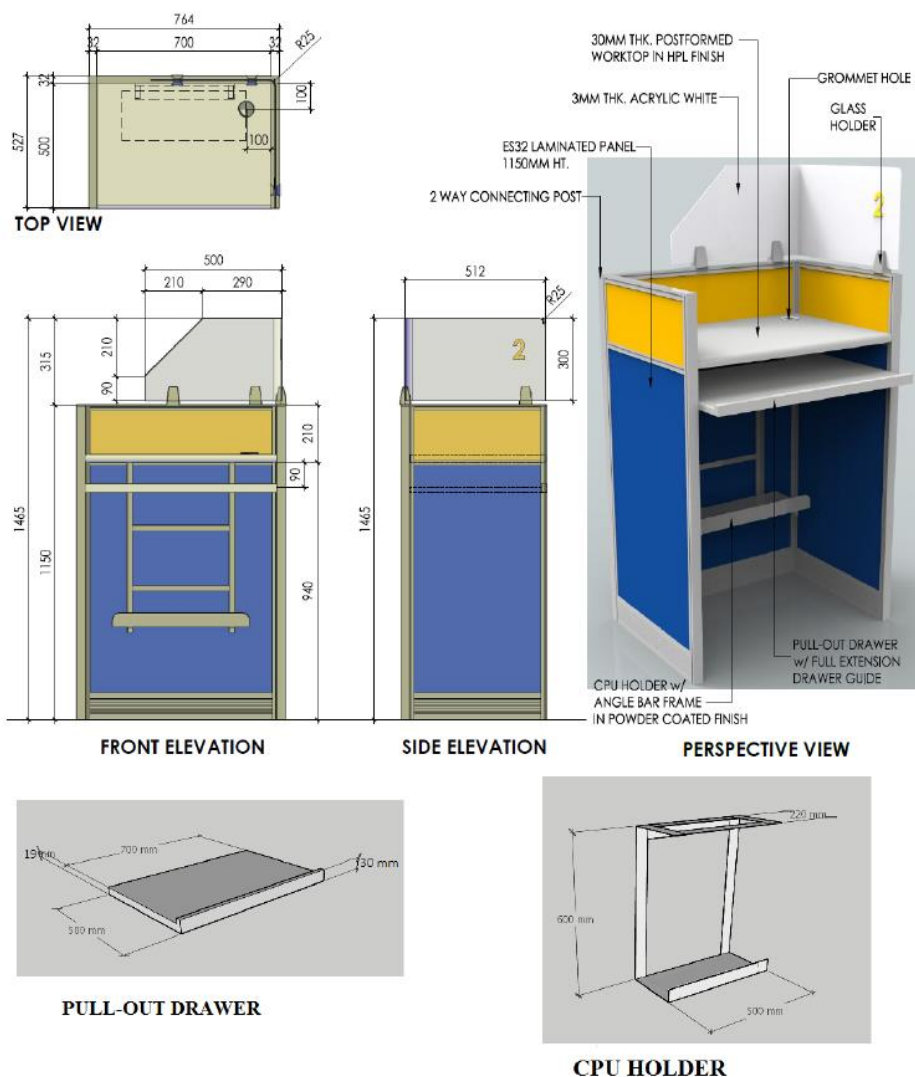

ID CAPTURE WORKSTATION

DESIGN	50mm thick Modular Partition with 2mm THK PVC Edging
CONSTRUCTION	
High Partition	1500 mm (H) using 50 mm thick modular panel in Teflon-coated fabric finish. Two-tone with 1/8" thick foam padding with adjustable gliders
Frame, Trim, Capping, and Corner Posts	Aluminum Extrusions in powder-coated finish. Submit sample for approval
Skirting/ Base	100mm (H) powder-coated aluminum panel with raceway for cables and three (3) knockouts for UPS / Normal Power / Datacom outlets.
COLOR/ FINISHES	
Modular Panel Fabric Upholstery	Two-tone, Titch brand fabric or approved equal. <i>Top: Titch "Sunrise";</i> <i>Bottom: Titch "Expensive Blue"</i>

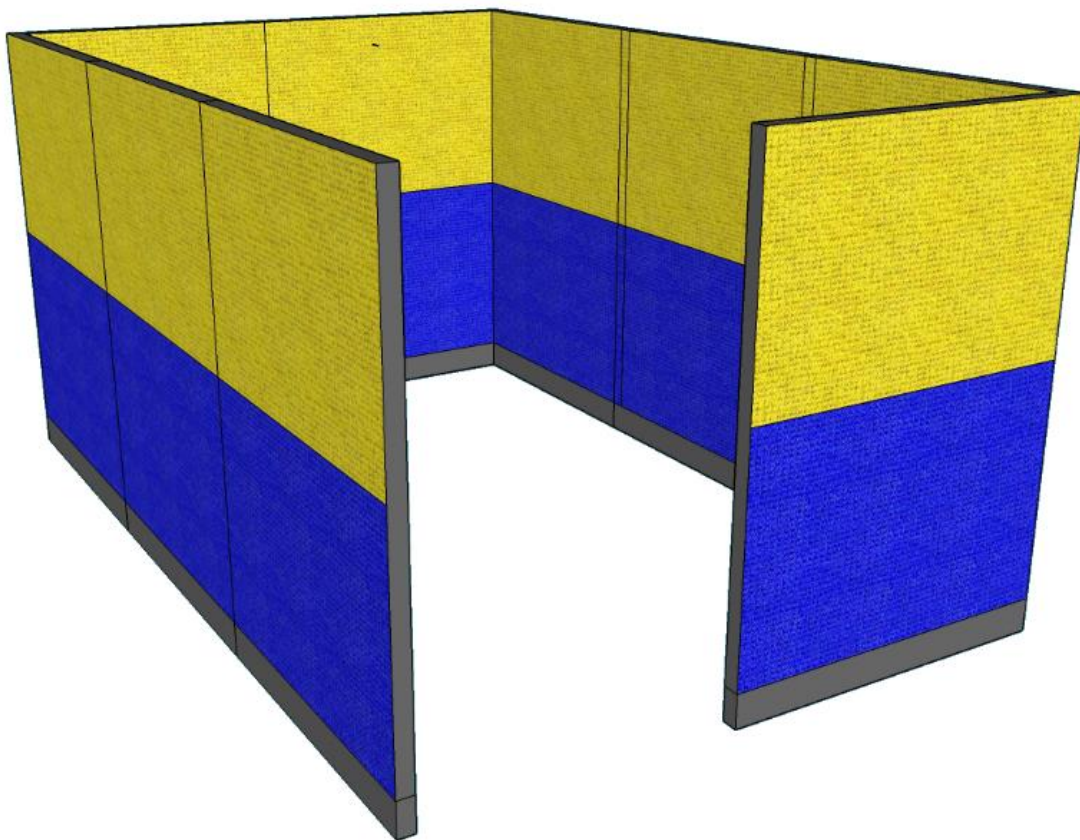

FREE-STANDING PRINTER TABLE - (FS1)

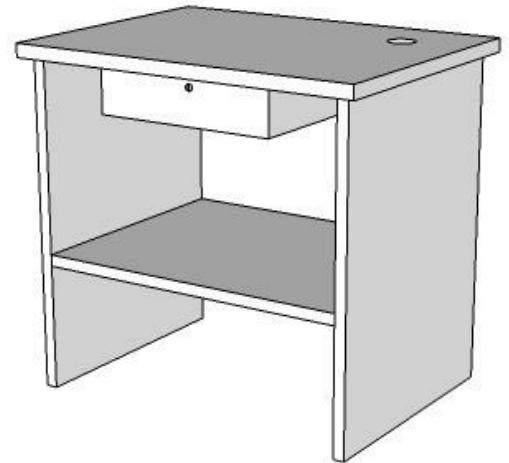

DESIGN	Free-standing rectangular desk in medium density fiber (MDF) board tabletop in HPL finish with lower shelf.
Dimensions	800mm (W) x 600mm (D) x 750mm (H)
CONSTRUCTION	
Tabletop	600 mm (D) x 800 mm (L) using 30 mm thick medium density fiber (MDF) board in high pressure laminate (HPL) finish, post-formed front/back edges with 2 mm thick PVC flat edging on side edges.
Leg/Support	25 mm thick medium density fiber (MDF) board in high pressure laminate (HPL) finish with 2mm thick PVC flat edging.
Shelves	25 mm thick medium density fiber (MDF) board in high pressure laminate (HPL) finish with 2mm thick PVC edging.
Drawer	400mm (W) x 350mm (D) x 100mm H, 19mm thick MDF board in HPL finish, with lock and recessed drawer pulls.
ACCESSORIES	
Foot Glide	Adjustable PVC foot glides, 2 pieces each panel.
Grommet	Plastic grommet with rotating cover.
COLOR / FINISHES	
High Pressure Laminate (HPL)	Formica or WilsonArt Laminates. <i>Tabletop and Supports : Folkstone "0927"</i>

FREE-STANDING COMPUTER TABLE – (FS2)

(For UMID Workstation)

DESIGN	Free-standing rectangular desk in medium density fiber (MDF) board tabletop and high pressure laminate (HPL) finish.
Dimensions	1000mm (W) x 600mm (D) x 750mm (H)
CONSTRUCTION	
Tabletop	600 mm (D) x 1000 mm (L) using 30 mm thick medium density fiber (MDF) board in high pressure laminate (HPL) finish, post-formed front/back edges with 2 mm thick PVC flat edging on side edges.
Leg/Support	Gauge 18 cold rolled steel in powder-coated finish; with PVC gliders on both supports and integrated cable management channel for power supply and datacom cables; Color: Black
Modesty Panel	Gauge 22 cold rolled steel in powder coated finish, complete with the necessary hardware and support for attachment to the tabletop and legs; Color: Black
ACCESSORIES	
Grommet	Plastic cable set with rotating cover; same color as worktop or white.
Raceway	integrated cable management channel for power supply and datacom cables;
COLOR / FINISHES	Specific colors subject for approval.
High Pressure Laminate (HPL)	Formica or WilsonArt Laminates: <i>Tabletop and Supports : Folkstone "0927"</i>
Legs/Modesty Panel	Powder-coated Black

EXECUTIVE CONFERENCE TABLE (6-SEATER)

(Conference Room for Small Branches Only)



DESIGN	6 or 8-seater boat-shaped conference table in medium density fiber (MDF) board in high pressure laminate (HPL) finish with wire management.
Dimensions	1200 mm (W) x 2400 mm (L) x 750 mm (H)
CONSTRUCTION	
Tabletop	30 mm thick medium density fiber (MDF) board in high pressure laminate (HPL) finish with 2mm thick PVC flat edging;
Legs/ Supports	30 mm thick medium density fiber (MDF) board in high pressure laminate (HPL) finish with 2mm thick PVC edging and adjustable PVC gliders on gable ends.

Modesty Panel	18 mm thick medium density fiber (MDF) board in high pressure laminate (HPL) finish with 2mm thick PVC edging.
Panel Connectors	Use recessed universal connectors.
COLOR	
High Pressure Laminate(HPL)	Formica or WilsonArt Laminates: <i>Tabletop: Lincoln Walnut code "7188"</i> <i>Support: Black "0909"</i>



EXECUTIVE CONFERENCE TABLE (12-SEATER)
 (Conference Room for Medium to Large Branch Only)

DESIGN	Modular floating tables supported by 40mm x 40mm tubular metal legs and beams.	
Dimensions	600mm (W) x 1500mm (L)x 750mm (H) per piece	
CONSTRUCTION		
Tabletop	30 mm thick medium density fiber (MDF) board in high pressure laminate (HPL) finish with 2 mm thick PVC flat edging.	
Legs/Supports	40mm x 40mm tubular metal legs in powder-coated finish	
COLOR		
High Pressure Laminate (HPL)	Formica or WilsonArt Laminates: <i>Tabletop:</i> Lincoln Walnut code "7188" <i>Support:</i> Black "0909"	

ROUND CONFERENCE TABLE



(Manager's Office)

DESIGN	4-seater round table in medium density fiber (MDF) board in high pressure laminates (HPL) finish.	
Dimensions	900 mm diameter x 750 mm (H)	
CONSTRUCTION		
Tabletop	30 mm thick medium density fiber (MDF) board in high pressure laminate finish (HPL) and 2 mm thick PVC flat edging same color as worktop.	
Supports/Legs	25 mm thick medium density fiber (MDF) board in high pressure laminate (HPL) finish with 2 mm thick PVC flat edging same color as worktop and adjustable PVC gliders on gable ends.	
COLOR		
High pressure Laminate (HPL)	Formica or WilsonArt Laminates: <i>Tabletop & Support:</i> Lincoln Walnut code "7188"	

EXECUTIVE CHAIR - (S1)

DESIGN	High-back swivel chair with synchronized tilt and swivel mechanism, recline and rocking feature, pneumatic seat height adjustment, rounded
---------------	--

	profile backrest with integral headrest, fixed padded armrest and 5-prong base.
Dimension	Backrest: 730 mm (H) x 490 mm (W)
	Seat: 490 mm (W) x 470 mm (D)
	Base Diameter: 640 to 670 mm
	Armrest Length: 240 mm - 300 mm
CONSTRUCTION	
Backrest	Reclining backrest with lumbar support made of plastic shell with high density molded foam, leatherette upholstery and rocking feature.
Tilt	Synchronized tilt/swivel mechanism that allows tilting forward at 80° and backward at 110°, with tilt tension adjustment, control lever that releases tilt for free float of backrest or tilt lock in a specific angle and safety feature that allows non-movement of backrest upon initial unlocking of lever.
Seat	Seat made of plastic shell with high density molded foam and upholstery.
Armrest	High Quality Chrome Solid Aluminum Fixed armrest and upholstered pads.
Gas Lift Mechanism	28mm diameter gas cylinder head with outer tube diameter of 50 mm - 60 mm, German Brand gas lift mechanism (Suspa, Stabilus or approved equal) Manufacturer's Certification required.
Wheel Casters	50 mm diameter twin wheel casters, nylon type.
Base	5-prong aluminum base or nylon base with crisscrossed inner core; load capacity of not less than 250 lbs (Manufacturer's Certification required).
Upholstery	Leatherette
COLOR	
Upholstery	Black
Frame/Base	Black nylon or glossy/satin metal finish.



SUPERVISOR'S CHAIR - (S2)

DESIGN	Mid-back swivel chair with synchronized tilt mechanism, pneumatic seat height adjustment, fixed contoured polypropylene armrest and 5-prong base.
Dimensions	Backrest Height: 550 mm
	Seat Width: 490 mm
	Seat Height: 470 mm (adjustable)
CONSTRUCTION	
Backrest	With lumbar support made of plastic shell and cushioned with high density molded foam.
Tilt	synchronized swivel/tilt mechanism that allows tilting forward at 80° and backward at 110°; with tilt tension adjustment, control lever that releases tilt for free float of backrest and safety feature that allows non-movement of backrest upon initial unlocking of lever.
Seat	Plastic shell with high density molded foam (Uratex or approved equal).
Armrest	Fixed contoured polypropylene arm frame and armrest.
Gas Lift Mechanism	28mm diameter gas cylinder head with outer tube diameter of 50 – 60 mm, German Brand gas lift mechanism (Suspa, Stabilus or approved equal) Manufacturer's Certification required.
Wheel Casters	50 mm diameter twin wheel casters, nylon type.
Base	5-prong metal or nylon base with crisscrossed inner core; load capacity of not less than 250 lbs (Manufacturer's Certification required).
Upholstery	Leatherette
COLOR	
Upholstery	Black
Frame/Base	Black nylon or glossy/satin metal finish.



NON-SUPERVISOR'S/STAFF AND CONFERENCE CHAIR - (S3)

DESIGN	Low back swivel chair with pneumatic seat height adjustment, single position tilt lock, molded polypropylene armrest and 5-prong nylon base.
---------------	--



Dimensions	Backrest Height: 460 mm
	Seat Width: 490 mm
	Seat Height: 584 mm to 838 mm
CONSTRUCTION	
Backrest	With lumbar support made of plastic shell with high density molded foam.
Tilt	Single position tilt lock or control lever which releases tilt for free float of backrest.
Seat	Made of plastic shell with high density molded foam (Uratex or approved equal).
Armrest	Fixed molded polypropylene arm frame and armrest.
Gas lift Mechanism	28mm diameter gas cylinder head with outer tube diameter of 50 – 60 mm, Suspa or Stabilus brand (Manufacturer's certification required).
Wheel Casters	50 mm diameter twin wheel casters, nylon type.
Base	5-prong black nylon base with crisscrossed inner core and load capacity of not less than 250 lbs (Manufacturer's Certification required).
Upholstery	Clerical Chair: Leatherette Conference Chair: Fabric
COLOR	
Upholstery	Clerical Chair: Black Conference Chair: Black

TELLER'S HIGH CHAIR WITH FOOTRING - (S4)

DESIGN	Low-back swivel chair with built-in lumbar support with pneumatic seat height adjustment, single position tilt lock, and 5-prong nylon base.
Dimensions	1170mm (H) x 660mm (W) x 660mm (D)
	Backrest Width: 458 mm
	Backrest Height: 460 mm
	Seat Width: 490 mm
	Seat Height: 470 mm (adjustable)
	Back Angle: 90 deg to 105 deg
CONSTRUCTION	
Tilt	Single position tilt lock or control lever which releases tilt for free float of backrest.
Backrest	With lumbar support made of plastic shell with high density molded foam.
Seat	Made of plastic shell with high density molded foam (Uratex or approved equal).
Gas Lift Mechanism	28mm diameter gas cylinder head with outer tube diameter of 50 – 60 mm, Suspa or Stabilus brand (Manufacturer's certification required).
Wheel Casters	50 mm diameter twin wheel casters, nylon type.
Foot Ring	18" diameter stainless steel foot ring.
Base	5-prong black nylon base with crisscrossed inner core and load capacity of not less than 250 lbs (Manufacturer's Certification required).
COLOR	
Upholstery	Pantone Blue Fabric



GUEST CHAIR 01 - (S5)

(For Executive Office)

DESIGN	Mid-back chair with cantilever tubular legs, cushioned seat and backrest, polypropylene armrest and cantilever legs.	
CONSTRUCTION		
Backrest and Seat	Polypropylene back and seat with 2" thick high density molded foam cushion (Uratex or approved equal) and leatherette upholstery.	
Legs	Tubular legs in powder-coated finish, cantilever-type; load capacity of not less than 250 lbs (Manufacturer's Certification is required).	
Arm/armrest	Fixed polypropylene armrest	
COLOR		
Upholstery	Pantone Blue Fabric	
Frame/Base	Black	

GUEST CHAIR 02 - (S6)

DESIGN	Low back chair with sled base in powder-coated finish; with armrest.	
CONSTRUCTION		
Backrest and Seat	Polypropylene back and seat with high density molded foam cushion (Uratex or approved equal), fabric upholstery and "waterfall" seat profile.	
Seat Support	parallel or intersecting ("X") seat support in tubular metal frame with seamless weld	
Frame/ Legs	18 mm (min.) diameter powder-coated tubular frame; sled-type base.	
COLOR		
Upholstery	Pantone Blue Fabric.	
Legs/ Frame	Black	

GANG CHAIR

DESIGN	4, 3-seater Powder Coated perforated Gang Chair	
Dimensions	4-seater – 2380mm x 680mm x 800mm with 3 leg support	
	3-seater – 1800mm x 680mm x 800mm with 2 leg support	
CONSTRUCTION		
Backrest and Seat	1.5mm perforated cold-rolled steel with powder coated finish	
Side Strips	2.2mm thick cold-rolled steel with surface chrome plating treatment	
Beam	1.8mm thick x 80mm x 40mm rectangular steel tube sprayed with static powder after anti-rust treatment	
Armrest/ Legs	1.2mm thick cold-rolled steel with surface chrome plating treatment	
COLOR		
Legs / Frame	Chrome finish	
Seat & Back	Powder Coated Blue	



GENERALIS'

DESIGN	L-shaped transaction counter in medium density fiber (MDF) board and marine plywood, high pressure laminate (HPL) finish, with built-in drawers and integrated outlet box/raceway for datacom/power outlets.
CONSTRUCTION	
Main Desk:	1400mm (W) x 750mm (D) x 750mm (H)
Worktop	30 mm thick MDF board with 1/2" thick synthetic stone in PVC film finish with 2 mm thick PVC edging and two (2) plastic grommet with rotating cover.
High partition / End panels	30mm thick MDF board in 2-tone high pressure laminate (HPL) finish with 2 mm thick PVC edging and adjustable PVC gliders. (refer to attached pictures)
Front Panel	25mm thick marine plywood panel with horizontal strips using 1/2" thick MDF board in HPL finish with embossed SSS logo in the middle. (verify logo dimensions with EMD)
Side Desk:	1000mm (W) x 450mm (D) x 750mm (H)
Worktop	30mm thick particle board in high-pressure laminate finish with 2 mm thick PVC edging and plastic grommet with rotating cover.
Modesty Panel	25 mm thick MDF board in HPL finish with 2 mm thick PVC edging and PVC gliders.
Side Supports	25 mm thick MDF board in HPL finish with 2 mm thick PVC edging and adjustable PVC gliders.
Under Counter Ledge	25mm thick MDF board in HPL finish with 2 mm thick PVC edging.
ACCESSORIES	
Raceway	19mm thick marine plywood integrated outlet box/raceway for UPS / Normal Power / Datacom outlets
Built-in drawer	400mm (W) x 600mm (D), 4 layers drawer in MDF board in HPL finish, with centralized lock and recessed drawer pulls.
SSS Logo	120 mm (W) x 100 mm (H), embossed SSS logo in 1.5 mm thick SS sheet. (verify dimensions with EMD)
Skirting	100 mm (H) Stainless Steel Skirting (Front Panel)
COLORS/ FINISHES	
High Pressure Laminate	Formica or WilsonArt Laminates: <i>Tabletop and Supports: Folkstone "0927" and Navy Blue "0969"</i> <i>Horizontal Strips: Navy Blue "0969" and Natural Maple "0756"</i>
Synthetic Stone	Cobalt Blue (Submit sample for approval)

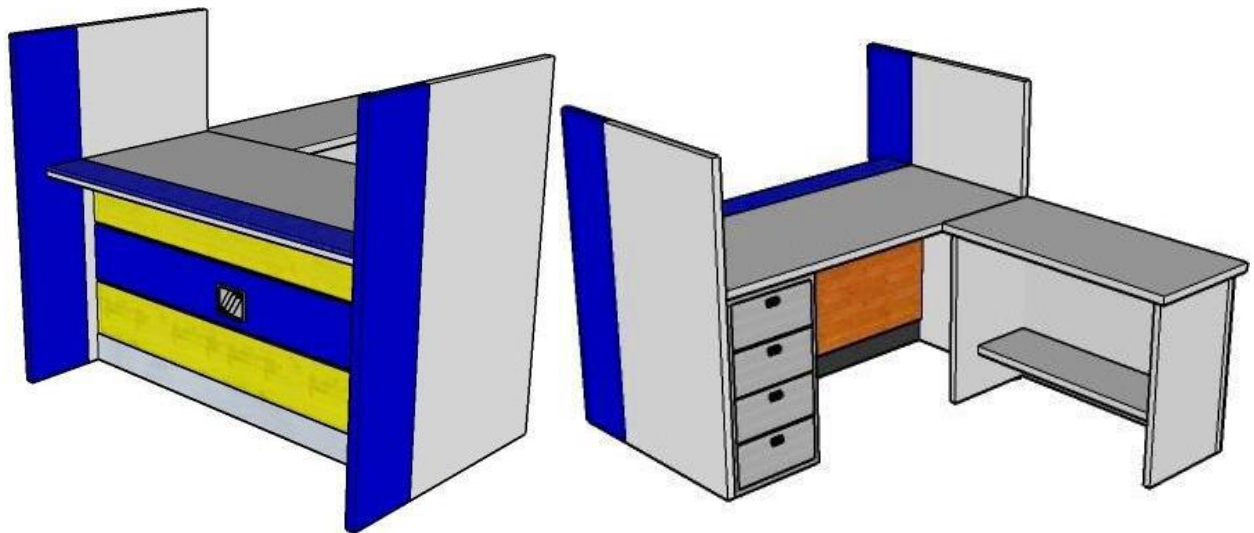

GENERAL INFORMATION BOOTH

DESIGN	U-shaped information booth in marine plywood carcass, HPL finish and provided with built-in shelves.
Dimensions	1800mm (W) x 1000mm (D) x 1100mm (H)
CONSTRUCTION	
Carcass/Body	3/4" thick marine plywood with horizontal strips of 1/4" thick plywood in HPL finish; provide stainless steel sheet skirting and PVC Gliders
Shelves	3/4" thick marine plywood, duco paint finish.
Worktop	3/4" thick marine plywood in HPL finish, with 50 mm thick built-up nosing and 2 mm thick PVC edging
ACCESSORIES	
SSS Logo	180 mm (W) x 150 mm (H), embossed SSS logo in 1.5 mm thick stainless steel sheet.(verify dimensions with EMD)
Skirting	100 mm (H) Stainless Steel Skirting (Front and Side Panel)
COLORS/ FINISHES	
High Pressure Laminate (HPL)	Formica or WilsonArt Laminates: <i>Tapleto</i> : Folkstone "0927" <i>Horizontal Strips</i> : Navy Blue "0969" and Natural Maple "0756"

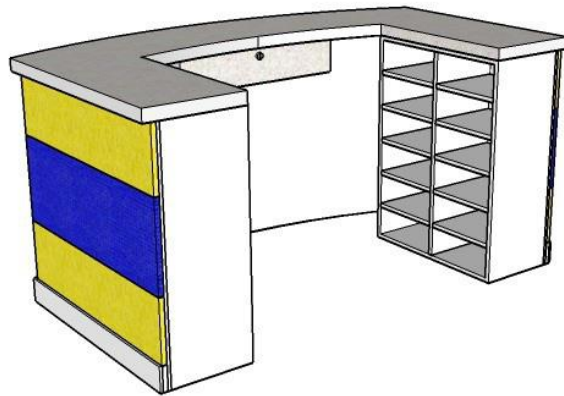
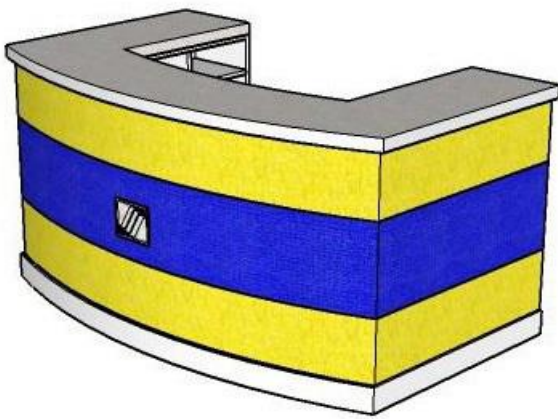

INFO

BOOTH

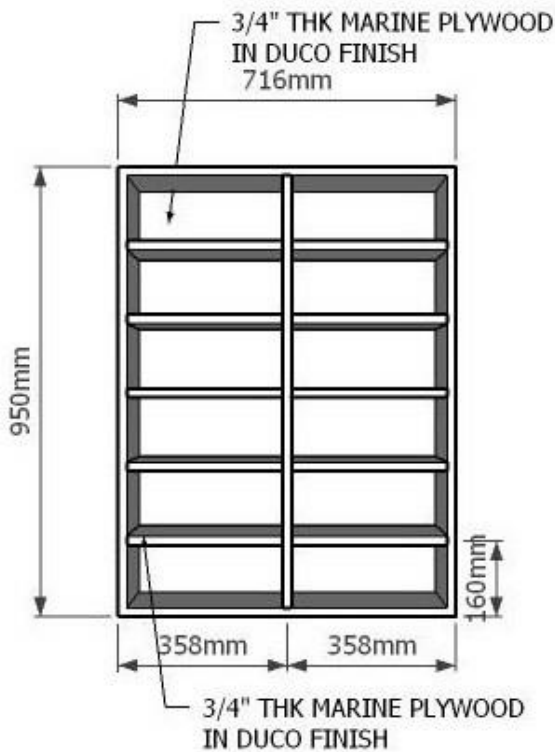

FORMS

**SHELVES
WRITING COUNTER – (FWC)**

DESIGN	Rectangular-shaped writing counter made of MDF board tabletop in high pressure laminate finish
Dimensions	1800mm (L) x 600mm (W) x 1000mm (H)
CONSTRUCTION	
Tabletop	30mm thick Medium Density Fiber (MDF) board in High Pressure Laminate (HPL) finish
Framing	2.00mm thick x 40mm Tubular in Powder Coated finish. Color: Submit sample for approval
COLORS/ FINISHES	
High pressure Laminate (HPL)	Formica or WilsonArt <i>Body:</i> Navy Blue "0969"

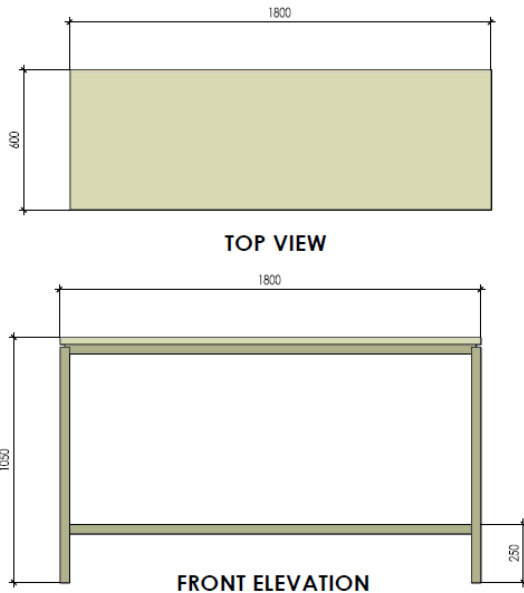

GUARD STATION – (GS)

DESIGN	D-shaped guard station in marine plywood carcass in HPL finish w/ 1/2" thick pure acrylic synthetic stone in PVC film finish and provided with built-in drawer.
Dimensions	600mm (D) x 800mm (W) x 1100mm (H)
CONSTRUCTION	
Carcass/Body	3/4" thick marine plywood in HPL finish with 6mm square groove and PVC gliders
Center Drawer w/ Lock	600mm W x 300mm D x 150mm H x 3/4" thick marine plywood in HPL finish with centerlock
Worktop	3/4" thick marine plywood in HPL finish; post-formed edges
Modesty Panel	1/4" thick Marine Plywood in HPL Finish
ACCESSORIES	
SSS Logo	180 mm (W) x 150 mm (H), embossed SSS logo in 1.5 mm thick stainless steel sheet.
Foot Rest	25mmØ Stainless Steel Footrest
COLORS/FINISHES	
High Pressure Laminate (HPL)	Formica or WilsonArt Laminates: <i>Worktop:</i> Folkstone "0927" <i>Body :</i> Navy Blue "0969"



MANAGER'S BACK CABINET - (MBC)

DESIGN	19mm thick marine plywood in HPL finish with 3 drawers and cabinets.
Dimensions	1800 mm (W) x 450 mm (D) x 750 mm (H)
CONSTRUCTION	
Body	19mm thick marine plywood in HPL finish with 2mm thick PVC edging same color with the HPL finish
Drawers	3/4" thick Marine Plywood in HPL finish
ACCESSORIES	
Cabinet/ Drawer Handle	Stainless Steel Handle
COLOR/ FINISHES	
High Pressure Laminate Finish	Formica or WilsonArt <i>Body: Lincoln Walnut code "7188"</i>



**OPEN
SHELVES (OSS)**

STEEL

DESIGN	6-Layer Open Steel Shelves in powder coated finish with Steel Stiffener on both sides.
Dimension	500mm (W) x 1000mm (D) x 2100mm (H)
CONSTRUCTION	
Vertical Post	Ga. #14 (2.0mm thk) cold-rolled steel and roll formed into a modified angle shape with 38mm x 38mm holes.
Shelves	Fabricated in cold-rolled sheet Ga. #18 (1.27mm) double bended on all side with bottom support in rectangular form, welded.
Stiffener	Ga. #18 (1.27mm) Steel Stiffener on both sides.
COLOR	Submit sample for approval



4-DRAWER LATERAL FILING CABINET

DESIGN	Powder-coated steel filing cabinet with four (4) pull-out drawers in metal glides, adjustable steel file dividers, anti-tilt mechanism, anti-tilt counterweight located at the bottom, built-in full recessed pull and central locking mechanism.
Dimension	900mm (W) x 500mm (D) x 1380mm (H)
CONSTRUCTION	
Cold rolled metal sheets in powder-coated finish, heavy-duty drawer suspension in ball bearing and zinc chromate finish with the following thickness:	
Pull-out Drawer	Fabricated in cold rolled shell Ga. #22 (0.80 mm) with 2 steel file divider and built-in PVC flush handle per drawer. Heavy-duty drawer suspension in ball-bearing slides and zinc chromate finish, with a minimum load capacity of 50 kgs/drawer (Manufacturer's certification required).
Interior Supports/ Braces	1.20 mm (Gauge # 18) cold-rolled steel
Carcase / Shell	Manufactured in cold rolled sheet Ga. #20 (0.90mm) with vertical support both sides, welded.
Rail	Made in heavy duty cold rolled sheet Ga. 17 (1.40mm) in full extension suspension on roller bearing in powder coated finish. With a minimum load capacity of 50kgs/drawer. (Manufacturer's Certification required)
COLOR	Light Gray (Submit sample for approval)



MOBILE PEDESTAL DRAWER

DESIGN	Cold Rolled steel with high quality powder coating finish with three (3) layer drawers in powder coated finish, with full extension ball-bearing slides, central lock system, recessed drawer pulls, with 2 pcs stationery tray/organizer and heavy-duty caster wheels.
Dimension	400mm (W) x 560mm (D) x 650mm (H)
CONSTRUCTION	
Body/Case	Manufactured in cold rolled sheet Ga. #22 (0.80mm) in powder coated finish.
Pull-out Drawer	Fabricated in cold rolled sheet Ga. #24 (0.60 mm) with central control lock on the top drawer.
Rail	Made in cold rolled sheet Ga. #20 (0.90mm), hang on roller bearing in powder coated finish.
Casters	Lockable Caster Wheel with fifth wheel for stability
COLOR	Submit sample for approval



GENERAL SPECIFICATIONS

- (1) Hooks and brackets shall be provided with locking devices to prevent accidental dismounting of worktop when attached to the panels/supports. Panels that are perpendicular or parallel to a fix wall shall be anchored to the wall using metal connectors, otherwise all assemblies shall be properly anchored to the floor.
- (2) Modular panels shall be fully interchangeable and can be dismantled or assembled without the use of special tools.
- (3) Panels and worktops with thickness that are not commercially available shall be fabricated using the same material, laminated together using appropriate adhesives and applicable technology.
- (4) Materials or accessories deemed necessary to complete the modular workstations but not specifically mentioned in the Specifications, Bid Breakdown Form, working drawings or in the other contract documents are inferred and shall be supplied, installed, and rendered by the contractor without extra cost to the owner. Such material shall be of the highest quality available and installed in an appropriate manner.

***Section VIII. Checklist of Technical and
Financial Documents***

Checklist of Technical and Financial Documents

I. TECHNICAL COMPONENT ENVELOPE

Class “A” Documents

Legal Documents

- (a) Valid PhilGEPS Certificate of Platinum Registration and Membership (Platinum Membership) (all pages);

Technical Documents

- (b) Statement of the prospective bidder of all its ongoing government and private contracts, including contracts awarded but not yet started, if any, whether similar or not similar in nature and complexity to the contract to be bid; **and**
- (c) Statement of the bidder’s Single Largest Completed Contract (SLCC) similar to the contract to be bid, except under conditions provided for in Sections 23.4.1.3 and 23.4.2.4 of the 2016 revised IRR of RA No. 9184, within 3 years period prior to the submission and receipt of Bids; **and**
- (d) Original copy of Bid Security (Cash, Letter of Credit, Surety Bond). If in the form of a Surety Bond, submit also a certification issued by the Insurance Commission; **Or** Original copy of Notarized Bid Securing Declaration; **and**
- (e) Conformity with the Schedule of Requirements (Section VI) and Technical Specifications (Section VII), which may include production/delivery schedule, manpower requirements, and/or after-sales/parts, if applicable; **and**
- (f) Original duly signed Omnibus Sworn Statement (OSS); **and** if applicable, Original Notarized Secretary’s Certificate in case of a corporation, partnership, or cooperative; or Original Special Power of Attorney of all members of the joint venture giving full power and authority to its officer to sign the OSS and do acts to represent the Bidder and copy Authority to Notarize issued to the Notary Public by the Regional Trial Court.

Other documentary requirements under RA No. 9184 (as applicable)

For foreign bidders claiming by reason of their country’s extension of reciprocal rights to Filipinos:

- (g) Copy of Treaty, International or Executive Agreement; **or**
- (h) Certification from the relevant government office of their country stating that Filipinos are allowed to participate in government procurement activities for the same item or product.
- (i) Certification from the DTI if the Bidder claims preference as a Domestic Bidder or Domestic Entity.

Class “B” Documents

- (j) If applicable, a duly signed joint venture agreement (JVA) in case the joint venture is already in existence;

or

duly notarized statements from all the potential joint venture partners stating that they will enter into and abide by the provisions of the JVA in the instance that the bid is successful.

Financial Documents

- (k) The Supplier’s audited financial statements, showing, among others, the Supplier’s total and current assets and liabilities, stamped “received” by the

BIR or its duly accredited and authorized institutions, for the preceding calendar year which should not be earlier than two (2) years from the date of bid submission; **and**

- (l) The prospective bidder's computation of Net Financial Contracting Capacity (NFCC);

or

A committed Line of Credit from a Universal or Commercial Bank in lieu of its NFCC computation.

II. FINANCIAL COMPONENT ENVELOPE

- (m) Original of duly signed and accomplished Financial Bid Form; and
- (n) Original of duly signed and accomplished Price Schedule(s)/Bid Breakdown and Bill of Quantities.

IMPORTANT REMINDERS

- A) Each and every page of the **Bid Forms/Price Schedule(s)/Breakdown**, under Section VIII: Checklist of Technical and Financial Documents hereof, shall be signed by the duly authorized representative/s of the Bidder. Failure to do so shall be a ground for the rejection of the bid.
- B) Any interlineations, erasures, or overwriting shall be valid only if they are signed or initialed by the duly authorized representative/s of the Bidder.
- C) Bid documents shall be compiled in a folder/binder with the Annexes properly labeled with tabs/separators.
- D) Bidders shall submit their bids through their duly authorized representative enclosed in separate sealed envelopes, which shall be submitted simultaneously:
- a) The first three individually sealed envelopes shall contain the folder/binder of the Eligibility Requirements and Technical Component of the bid; prepared in three copies labeled as follows:
- Envelop (1): ORIGINAL – Eligibility Requirements and Technical Component
Envelop (2): COPY1 – Eligibility Requirements and Technical Component
Envelop (3): COPY2 – Eligibility Requirements and Technical Component
- b) The next three individually sealed envelopes shall contain the folder/binder of the Financial Component of the bid; prepared in three copies labeled as follows:
- Envelop (4): ORIGINAL – Financial Component
Envelop (5): COPY1 – Financial Component
Envelop (6): COPY2 – Financial Component
- c) Bidders shall enclose, seal and mark the following:
- Envelop (7): Envelope (1) and Envelope (4) enclosed in one sealed envelope marked "ORIGINAL-BID"
- Envelop (8): Envelope (2) and Envelope (5) enclosed in one sealed envelope marked "COPY1-BID"



Envelop (9): Envelope (3) and Envelope (6) enclosed in one sealed envelope marked "COPY2-BID"

- d) Envelopes (7) to (9) shall then be enclosed in a single sealed, signed final/outer envelope/package/box
- e) All envelopes (Envelopes (1) to (9) and the final/outer envelope/package/box) shall indicate the following:
 - addressed to the Procuring Entity's BAC
 - name and address of the Bidder in capital letters
 - name of the contract/project to be bid in capital letters
 - bear the specific identification/reference code of this bidding process
 - bear a warning "DO NOT OPEN BEFORE..." the date and time for the opening of bids

<p>THE CHAIRPERSON BIDS AND AWARDS COMMITTEE 2ND FLOOR, SSS MAIN BUILDING EAST AVENUE, DILIMAN, QUEZON CITY</p> <p>NAME OF BIDDER : _____ ADDRESS : _____</p> <p>NAME OF PROJECT: _____ ITB REFERENCE NUMBER: _____</p> <p style="text-align: center;">DO NOT OPEN BEFORE (the date and time for the opening of bids)</p>

- E) Bids submitted after the deadline shall only be marked for recording purpose, shall not be included in the opening of bids, and shall be returned to the bidder unopened.
- F) Bidders shall submit a copy of the Authority to Notarize issued by the Regional Trial Court to the Notarial Public.

FORMS

Bid Form for the Procurement of Goods

BID FORM

**SUPPLY, DELIVERY AND INSTALLATION OF MODULAR OFFICE SYSTEM
AND FURNITURE FOR VARIOUS SSS BRANCH OFFICES
Lot I: NCR and Nearby Luzon Branches**

Date: _____

Project Identification No.: _____

To: **SOCIAL SECURITY SYSTEM**
East Avenue, Diliman, Quezon City

Having examined the Philippine Bidding Documents (PBDs) including the Supplemental or Bid Bulletin Numbers [insert numbers], the receipt of which is hereby duly acknowledged, we, the undersigned, offer to Supply, Delivery and Installation of Modular Office System and Furniture for Various SSS Branch Offices - Lot I: NCR and Nearby Luzon Branches in conformity with the said PBDs for the sum of [total Bid amount in words and figures] or the total calculated bid price, as evaluated and corrected for computational errors, and other bid modifications in accordance with the Price Schedules/Bid Breakdown attached herewith and made part of this Bid. The total bid price includes the cost of all taxes, such as, but not limited to: [specify the applicable taxes, e.g. (i) value added tax (VAT), (ii) income tax, (iii) local taxes, and (iv) other fiscal levies and duties], which are itemized herein or in the Price Schedules/Bid Breakdown,

If our Bid is accepted, we undertake:

- a. to deliver the goods in accordance with the delivery schedule specified in the Schedule of Requirements of the Philippine Bidding Documents (PBDs);
- b. to provide a performance security in the form, amounts, and within the times prescribed in the PBDs;
- c. to abide by the Bid Validity Period specified in the PBDs and it shall remain binding upon us at any time before the expiration of that period.

[Insert this paragraph if Foreign-Assisted Project with the Development Partner:

Commissions or gratuities, if any, paid or to be paid by us to agents relating to this Bid, and to contract execution if we are awarded the contract, are listed below:

Name and address of agent	Amount and Purpose of Commission or gratuity
_____	_____
_____	_____
_____	_____

(if none, state "None")

Until a formal Contract is prepared and executed, this Bid, together with your written acceptance thereof and your Notice of Award, shall be binding upon us.



We understand that you are not bound to accept the Lowest Calculated Bid or any Bid you may receive.

We certify/confirm that we comply with the eligibility requirements pursuant to the PBDs.

The undersigned is authorized to submit the bid on behalf of [name of the bidder] as evidenced by the attached [state the written authority].

We acknowledge that failure to sign each and every page of this Bid Form, including the attached Schedule of Prices/Bid Breakdown, shall be a ground for the rejection of our bid.

Name: _____

Legal capacity: _____

Signature: _____

Duly authorized to sign the Bid for and behalf of: _____

Date: _____



Bid Form for the Procurement of Goods

BID FORM

**SUPPLY, DELIVERY AND INSTALLATION OF MODULAR OFFICE SYSTEM
AND FURNITURE FOR VARIOUS SSS BRANCH OFFICES
Lot II: Luzon Branches**

Date: _____

Project Identification No.: _____

To: **SOCIAL SECURITY SYSTEM**
East Avenue, Diliman, Quezon City

Having examined the Philippine Bidding Documents (PBDs) including the Supplemental or Bid Bulletin Numbers [insert numbers], the receipt of which is hereby duly acknowledged, we, the undersigned, offer to Supply, Delivery and Installation of Modular Office System and Furniture for Various SSS Branch Offices - Lot II: Luzon Branches in conformity with the said PBDs for the sum of [total Bid amount in words and figures] or the total calculated bid price, as evaluated and corrected for computational errors, and other bid modifications in accordance with the Price Schedules/Bid Breakdown attached herewith and made part of this Bid. The total bid price includes the cost of all taxes, such as, but not limited to: [specify the applicable taxes, e.g. (i) value added tax (VAT), (ii) income tax, (iii) local taxes, and (iv) other fiscal levies and duties], which are itemized herein or in the Price Schedules/Bid Breakdown,

If our Bid is accepted, we undertake:

- a. to deliver the goods in accordance with the delivery schedule specified in the Schedule of Requirements of the Philippine Bidding Documents (PBDs);
- b. to provide a performance security in the form, amounts, and within the times prescribed in the PBDs;
- c. to abide by the Bid Validity Period specified in the PBDs and it shall remain binding upon us at any time before the expiration of that period.

[Insert this paragraph if Foreign-Assisted Project with the Development Partner:

Commissions or gratuities, if any, paid or to be paid by us to agents relating to this Bid, and to contract execution if we are awarded the contract, are listed below:

Name and address of agent	Amount and Currency	Purpose of Commission or gratuity
_____	_____	_____
_____	_____	_____
_____	_____	_____

(if none, state "None")

Until a formal Contract is prepared and executed, this Bid, together with your written acceptance thereof and your Notice of Award, shall be binding upon us.



We understand that you are not bound to accept the Lowest Calculated Bid or any Bid you may receive.

We certify/confirm that we comply with the eligibility requirements pursuant to the PBDs.

The undersigned is authorized to submit the bid on behalf of [name of the bidder] as evidenced by the attached [state the written authority].

We acknowledge that failure to sign each and every page of this Bid Form, including the attached Schedule of Prices/Bid Breakdown, shall be a ground for the rejection of our bid.

Name: _____

Legal capacity: _____

Signature: _____

Duly authorized to sign the Bid for and behalf of: _____

Date: _____



Bid Form for the Procurement of Goods

BID FORM

SUPPLY, DELIVERY AND INSTALLATION OF MODULAR OFFICE SYSTEM AND FURNITURE FOR VARIOUS SSS BRANCH OFFICES

Lot III: VisMin Branches

Date: _____

Project Identification No.: _____

To: **SOCIAL SECURITY SYSTEM**
East Avenue, Diliman, Quezon City

Having examined the Philippine Bidding Documents (PBDs) including the Supplemental or Bid Bulletin Numbers [insert numbers], the receipt of which is hereby duly acknowledged, we, the undersigned, offer to Supply, Delivery and Installation of Modular Office System and Furniture for Various SSS Branch Offices - Lot III: VisMin Branches in conformity with the said PBDs for the sum of [total Bid amount in words and figures] or the total calculated bid price, as evaluated and corrected for computational errors, and other bid modifications in accordance with the Price Schedules/Bid Breakdown attached herewith and made part of this Bid. The total bid price includes the cost of all taxes, such as, but not limited to: [specify the applicable taxes, e.g. (i) value added tax (VAT), (ii) income tax, (iii) local taxes, and (iv) other fiscal levies and duties], which are itemized herein or in the Price Schedules/Bid Breakdown,

If our Bid is accepted, we undertake:

- a. to deliver the goods in accordance with the delivery schedule specified in the Schedule of Requirements of the Philippine Bidding Documents (PBDs);
- b. to provide a performance security in the form, amounts, and within the times prescribed in the PBDs;
- c. to abide by the Bid Validity Period specified in the PBDs and it shall remain binding upon us at any time before the expiration of that period.

[Insert this paragraph if Foreign-Assisted Project with the Development Partner:

Commissions or gratuities, if any, paid or to be paid by us to agents relating to this Bid, and to contract execution if we are awarded the contract, are listed below:

Name and address of agent	Amount and Purpose of Commission or gratuity
_____	_____
_____	_____

(if none, state "None")

Until a formal Contract is prepared and executed, this Bid, together with your written acceptance thereof and your Notice of Award, shall be binding upon us.

We understand that you are not bound to accept the Lowest Calculated Bid or any Bid you may receive.



We certify/confirm that we comply with the eligibility requirements pursuant to the PBDs.

The undersigned is authorized to submit the bid on behalf of [name of the bidder] as evidenced by the attached [state the written authority].

We acknowledge that failure to sign each and every page of this Bid Form, including the attached Schedule of Prices/Bid Breakdown, shall be a ground for the rejection of our bid.

Name: _____

Legal capacity: _____

Signature: _____

Duly authorized to sign the Bid for and behalf of: _____

Date: _____



Price Schedule(s)/Bid Breakdown

Name of Bidder _____

Invitation to Bid Number _____

Cost Component (Note: Include all applicable components)	Quantity	Cost per Branch	Total Cost
See Form Supplied Price Schedule(s)/ Bid Breakdown together with Bill of Quantities			
TOTAL			

Note:

1. Any bid exceeding the sub-limit per branch shall not be accepted.
2. Bids must be inclusive of freight cost and all applicable charges and taxes.
3. Fill up all required items/field in the bid breakdown. Failure to indicate any of the following shall mean outright disqualification since bid is considered Non-Responsive.
 - If the item is given for free, indicate dash (-), zero (0) or free
 - If the item is not applicable, indicate N/A
4. All documents shall be signed, and each and every page thereof shall be initialed, by the duly authorized representative/s of the Bidder.
5. Warranty requirement is at no cost to SSS.

Name: _____

Legal capacity: _____

Signature: _____

Duly authorized to sign the Bid for and behalf of: _____





Republic of the Philippines
SOCIAL SECURITY SYSTEM

East Ave., Diliman, Quezon City
 Tel. Nos. (832) 920-8401 * (832) 920-8464

Project : SUPPLY, DELIVERY AND INSTALLATION OF MODULAR OFFICE SYSTEMS AND FURNITURE FOR
 VARIOUS SSS BRANCHES OFFICES
 Lot I - NCR and Nearby Luzon Branches

PRICE SCHEDULE(S)/ BID BREAKDOWN

	SSS BRANCH NAME	SUB-LIMIT	QTY	UNIT	TOTAL AMOUNT
1	SSS MALABON	3,937,222.00	1	LOT	
2	SSS PASAY-ROXAS	4,565,224.00	1	LOT	
3	SSS MARIKINA	4,439,114.40	1	LOT	
4	SSS TAGAYTAY	4,166,045.84	1	LOT	
5	SSS ROSARIO-EPZA	4,419,367.00	1	LOT	
GRAND TOTAL					

Amount in Words:	
-------------------------	--

Note:

- 1 Any bid exceeding the sub-limit per branch shall not be accepted.
- 2 Bids must be inclusive of freight cost and all applicable charges and taxes.
- 3 Fill up all required items/field in the bid breakdown. Failure to indicate any of the following shall mean outright disqualification since bid is considered Non-Responsive.
 - If the item is given for free, indicate dash (-), zero (0) or free
 - If the item is not applicable, indicate N/A
- 4 All documents shall be signed, and each and every page thereof shall be initialed, by the duly authorized representative/s of the Bidder.
- 5 Warranty requirement is at no cost to SSS.

Name: _____

Legal capacity: _____

Signature: _____

Duly authorized to sign the Bid for and behalf of: _____



Project **SUPPLY, DELIVERY AND INSTALLATION OF MODULAR OFFICE SYSTEM AND FURNITURE FOR VARIOUS SSS BRANCH OFFICES**
 Location **SSS Malabon, 4/F Malabon Citysquare, C-4 Road Corner Dagat-dagatan Avenue, Longos, Malabon City**

BILL OF QUANTITIES

ITEM	DESCRIPTION		QTY	UNIT	UNIT COST	VAT (12%)	TOTAL COST
(A)	(B)		(C)	(D)	(E)	(F)	(G)
I	MODULAR OFFICE SYSTEMS						
	1. Branch Head Workstation (BHW)						
a.	1	pc.	D-shaped Free-Standing Executive Table, 1800mm L x 750mm D x 750mm H in 30mm thick MDF Board Tabletop w/ Plastic Grommet w/ Rotating Cover and 25mm thick MDF Board Side Support in HPL Finish				
b.	1	pc.	1.0	set		-	-
	Side Return Table 1200mm L x 450mm D x 750mm H x 30mm thick MDF Board CS/ Tabletop w/ Plastic Grommet w/ Rotating Cover, Ga.18 Weld Sheet in Powder Coated Finish, Legs Support and Ga.32 Sheet Modesty Panel in Powder Coated Finish						
c.	Accessories						
1.	1	pc.	Center Drawer, 540mm W x 400mm D x 95mm H				
2.	1	pc.	Keyboard Tray, Hard Plastic				
	2. Section Head Workstation (SHW-1)						
a.	Modular Panels & Supports						
1.	8	pcs.	Fabric Screen Panel, Two-tone, 1200mm W x 1200mm H x 50mm thick with Powder Coated Aluminum Panel Raceway for Cable & Outlets				
2.	8	pcs.	Fabric Screen Panel, Two-tone, 550mm W x 1200mm H x 50mm thick with Powder Coated Aluminum Panel Raceway for Cable & Outlets				
3.	8	pcs.	Fabric Screen Panel, Two-tone, 450mm W x 1200mm H x 50mm thick with Powder Coated Aluminum Panel Raceway for Cable & Outlets				
4.	8	pcs.	Fabric Screen Panel, Monotone, 1500mm W x 720mm H x 50mm thick with Powder Coated Aluminum Panel Raceway for Cable & Outlets				
5.	8	pcs.	Fabric Screen Panel, Two-tone, 550mm W x 900mm H x 50mm thick with Powder Coated Aluminum Panel Raceway for Cable & Outlets				
6.	8	pcs.	8.0	sets		-	-
	Aluminum End Trim, 1200mm H						
7.	8	pcs.	Aluminum End Trim, 900mm H				
8.	8	pcs.	Aluminum End Trim, 480mm H				
9.	8	pcs.	Aluminum End Trim, 180mm H				
10.	16	pcs.	Corner Post, 2-way, 1200mm H				
11.	8	pcs.	Corner Post, 2-way, 900mm H				
b.	Modular Worktop						
1.	8	pcs.	Rectangular Worktop, 1500mm L x 600mm W x 30mm thick MDF Board in HPL Finish, w/ Spcl. Plastic Grommet w/ Rotating Cover				
2.	8	pcs.	Rectangular Worktop, 1200mm L x 450mm W x 30mm thick MDF Board in HPL Finish, w/ Spcl. Plastic Grommet w/ Rotating Cover				
c.	Accessories						
1.	8	units	Center Drawer, 540mm W x 400mm D x 95mm H				
2.	8	units	Keyboard Tray, Hard Plastic				
	3. Staff Workstation (SW-1)						
a.	Modular Panels & Supports						
1.	12	pcs.	Fabric Screen Panel, Monotone, 1200mm W x 720mm H x 50mm thick with Powder Coated Aluminum Panel Raceway for Cable & Outlets				
2.	24	pcs.	Fabric Screen panel, Two-tone, 550mm W x 900mm H x 50mm thick with Powder Coated Aluminum Panel Raceway for Cable & Outlets				
3.	24	pcs.	Aluminum End Trim, 900mm H				
4.	24	pcs.	Aluminum End Trim, 180mm H				
5.	24	pcs.	Corner Post, 2-way, 900mm H				
b.	Modular Worktop						
1.	12	pcs.	Rectangular Worktop, 1200mm L x 600mm W x 30mm thick MDF Board in HPL Finish, w/ Spcl. Plastic Grommet w/ Rotating Cover				
c.	Accessories						
1.	12	units	Keyboard Tray, Hard Plastic				
	4. Staff Workstation (SW-2)						
a.	Modular Panels & Supports						
1.	3	pcs.	Fabric Screen Panel, Two-tone, 1200mm W x 1200mm H x 50mm thick with Powder Coated Aluminum Panel Raceway for Cable & Outlets				
2.	4	pcs.	Fabric Screen panel, Two-tone, 550mm W x 900mm H x 50mm thick with Powder Coated Aluminum Panel Raceway for Cable & Outlets				
3.	4	pcs.	Aluminum End Trim, 900mm H				
4.	4	pcs.	Aluminum End Trim, 300mm H				
5.	4	pcs.	Corner Post, 2-way, 1200mm H				
b.	Modular Worktop						
1.	3	pcs.	Rectangular Worktop, 1200mm L x 600mm W x 30mm thick MDF Board in HPL Finish, w/ Spcl. Plastic Grommet w/ Rotating Cover				
c.	Accessories						
1.	3	units	Keyboard Tray, Hard Plastic				
	5. Staff Workstation (SW-3: four-wheeler back to back)						
a.	Modular Panels & Supports						
1.	2	pcs.	Fabric Screen Panel, Two-tone, 1200mm W x 1200mm H x 50mm thick with Powder Coated Aluminum Panel Raceway for Cable & Outlets				
2.	4	pcs.	Fabric Screen panel, Two-tone, 550mm W x 900mm H x 50mm thick with Powder Coated Aluminum Panel Raceway for Cable & Outlets				
3.	4	pcs.	Aluminum End Trim, 900mm H				
4.	4	pcs.	Aluminum End Trim, 300mm H				
5.	2	pcs.	Corner Post, 3-way, 1200mm H				
6.	1	pc.	Corner Post, 4-way, 1200mm H				
b.	Modular Worktop						
1.	4	pcs.	Rectangular Worktop, 1200mm L x 600mm W x 30mm thick MDF Board in HPL Finish, w/ Spcl. Plastic Grommet w/ Rotating Cover				
c.	Accessories						
1.	4	units	Keyboard Tray, Hard Plastic				

ITEM	DESCRIPTION	QTY	UNIT	UNIT COST	VRP (12%)	TOTAL COST
(A)	(B)	(C)	(D)	(E)	(F)	(G)
	4. Computer Workstation (For BMC)					
	Free Standing Computer Table (F12), 1000mm L x 400mm D x 750mm H x 30mm Hx, MDF based in HPL, Finish, Post Formed Panel & Back Bridges w/ Dia. 18 Legs Support Powder Coated Finish w/ Integrated Cable Management Channel w/ Plastic Channel w/ Rolling Cover	10	units		-	-
	7. ID Capture Workstation					
	7a. Mobile Panels & Supports					
	1. 14 p/n. Polaris Screen Panel, Two-tone, 1000mm W x 1800mm H x 30mm Hx with Powder Coated Aluminium Panel Backing for Cables & Outlets	14	units		-	-
	2. 4 p/n. Corner Pad, 3-way, 1800mm H	4	units		-	-
	3. 4 p/n. Aluminium End Trim, 1800mm H	4	units		-	-
	7b. Counter Station (1700mm Subtotal length)					
	7b. Mobile Panels & Supports					
	1. 20 p/n. Polaris Screen Panel, Two-tone, 800mm W x 1100mm H x 30mm Hx with Powder Coated Aluminium Panel Backing for Cables & Outlets	20	units		-	-
	2. 10 p/n. Polaris Screen Panel, Two-tone, 700mm W x 1100mm H x 30mm Hx with Powder Coated Aluminium Panel Backing for Cables & Outlets	10	units		-	-
	3. 20 p/n. Aluminium End Trim, 1100mm H	20	units		-	-
	4. 20 p/n. Corner Pad, 3-way, 1100mm H	20	units		-	-
	7b. Mobile Worktop					
	1. 10 p/n. Rectangular Worktop, 700mm L x 800mm W x 30mm Hx, MDF based in HPL, Finish, w/ 1 p/n. Plastic Channel w/ Rolling Cover	10	units		-	-
	7b. Accessories					
	1. 10 p/n. CPU Holder	10	units		-	-
	2. 10 p/n. Acrylic Plastic Divider	10	units		-	-
	3. 10 p/n. Polished Cover for Scanner	10	units		-	-
	8. Desks & Tables					
	Free Standing Table (F1) - 800mm L x 400mm D x 740mm H, MDF based in HPL, Finish w/ Plastic Channel w/ Rolling Cover	40	units		-	-
	Executive Conference Table (3-seater, Back Slope w/ Wire Management) MDF based in HPL, Finish	1.0	unit		-	-
	Board Conference Table, 1000mm dia, MDF based in HPL, Finish	1.0	unit		-	-
	SUB-TOTAL - IOP II - MODULAR OFFICE SYSTEM					-
II	SEATED FURNITURE					
	1. 21 - Reception Chair, 2-piece, High Back	21.00	units		-	-
	2. 21 - Supervisor's Chair, 1-piece, Mid Back w/ Armrest	8.00	units		-	-
	3. 21 - Non-Supervisor's Chair/Staff Chair, 1-piece, Low Back w/ Armrest	38.00	units		-	-
	4. 21 - Teller's High Chair w/ Footrest, 2-piece, Mid Back	1.00	unit		-	-
	5. 21 - Guest Chair 1, 2-piece, Mid Back, Curved Top (For Reception) w/ Armrest	2.00	units		-	-
	6. 21 - Guest Chair 2, 2-piece, Mid Back w/ Armrest, w/ Foam Cushion	34.00	units		-	-
	7. 21 - 4 Seater Dining Chair, 200mm x 200mm x 80mm, Powder Coated Steel	20.00	units		-	-
	SUB-TOTAL - IOP II - SEATED FURNITURE					-
III	CONTRACT FURNITURE					
	1. Transaction Counter / General Counter (2x2)					
	1a. Mobile Panels & Supports					
	1. 8 p/n. Side Support Panel, 800mm W x 1200mm H x 30mm Hx, MDF based in HPL, Finish	8	units		-	-
	2. 4 p/n. Front Mobility Panel, 1400mm W x 700mm H x 30mm Hx, Marine Plywood w/ Horizontal Slats using 1/2" Hx, MDF based in HPL, Finish	4	units		-	-
	3. 4 p/n. Side Mobility Panel, 1000mm W x 700mm H x 30mm Hx, MDF based in HPL, Finish	4	units		-	-
	4. 8 p/n. Side Support Panel, 800mm W x 700mm H x 30mm Hx, MDF based in PVC Film Finish	8	units		-	-
	1b. Mobile Worktop					
	1. 4 p/n. Rectangular Worktop, 1400mm L x 700mm W x 30mm Hx, w/ Synthetic Stone (Acrylic) w/ Plastic Channel w/ Rolling Cover	4	units		-	-
	2. 4 p/n. Rectangular Worktop, 1000mm L x 400mm W x 30mm Hx, w/ Synthetic Stone (Acrylic) w/ Plastic Channel w/ Rolling Cover	4	units		-	-
	3. 4 p/n. Undercounter Ledge, 800mm L x 200mm W x 30mm Hx, Particle Board in HPL, Finish w/ Plastic Channel w/ Rolling Cover	4	units		-	-
	1c. Accessories					
	1. 4 p/n. 4-layer Bullfinch Drawer, 400mm W x 400mm D x 30mm Hx, MDF based in HPL, Finish	4	units		-	-
	2. 4 p/n. 120mm W x 100mm H ID Logo in Stainless Steel Sheet	4	units		-	-
	3. 4 p/n. Reinforced Tray, Hard Plastic	4	units		-	-
	2. Information Booth (Info)					
	Dropped, 1800mm L x 1000mm W x 1100mm H x 15mm Hx, Marine Plywood Corcose w/ Bullfinch Drawers	1.0	unit		-	-
	3. Name Writing Counter (NWC)					
	400mm W x 1800mm L x 150mm H Rectangular Shaped Writing Counter made of MDF based on top w/ HPL Side and Aluminium-coated tubular backing leg	40	units		-	-
	4. Guard's Pad					
	Dropped Guard Station in Marine Plywood Corcose, HPL, Finish w/ Bullfinch Drawers, Stainless Steel Detailing & Reinforced Logo	20	units		-	-
	5. Manager's Desk Cabinet (MDC)					
	1800mm W x 600mm D x 700mm H 15mm Hx, Marine Plywood in PVC Film Finish or Approved Equal	1.0	unit		-	-
	SUB-TOTAL - IOP III - CONTRACT FURNITURE					-
IV	ITEMS, SUPPLIES, CABINETS & DRAWERS					
	1. Open Steel Drawers (OSD) 4-layer, 12x18	20.0	units		-	-
	2. Lateral filing Cabinet, 4-Drawers	1.0	units		-	-
	3. Mobile Perforated Drawers 3-Drawers, 400mm W x 600mm D x 60mm H	20.0	units		-	-
	SUB-TOTAL - IOP IV - ITEMS, SUPPLIES, CABINETS & DRAWERS					-
	GRAND TOTAL					-

ITEM	DESCRIPTION	UNIT	UNIT	UNIT CODE	UNIT (17%)	UNIT CODE
(A)	(B)	(C)	(D)	(E)	(F)	(G)

GENERAL CONDITIONS

- For uniformity and evaluation purposes, a bidder shall adhere to the herein prescribed format of BOC, specifically to the format for computation, given quantity and inclusive pay items. Any deviation from the format shall be a ground for disqualification of bid.
 - Fill up of required items/field in the BOC. Failure to indicate any of the following shall mean outright disqualification since bid is considered non-responsive:
 - If item is given for free, indicate dash (-), zero (0) or free
 - If the item is not applicable, indicate N/A
- Each bidder shall be provided with hard copy of the BOC Form (attached in the PEO) and an electronic copy for faster and easier encoding. The hard copy shall serve as the bidder's reference as to completeness of each item, quantity, formula, format, etc. in the BOC Form considering that the electronic copy is prone to alterations during encoding. Any discrepancy on the contents (specifically on the quantity and inclusive pay items) between the hard copy and electronic, the contents of the hard copy shall prevail.
- Bidder ~~are~~ **not** allowed to include any pay items that were not included in the form supplied by the Committee. In instances where necessary work items are inadvertently left out in BOC Form, a bidder should make a written query to the Bids and Awards Committee so that the same shall be addressed in the Bid Subject which will be issued to all participating bidders.
- All documents must be signed, and each and every page thereof must be initialed by the duly authorized representative/s of the Bidder.
 - Unit Price of the Purchase Item shall include the following:
 - Materials, Subcontract and installation costs
 - Overhead expenses such as office expenses, supervision, transportation allowances, and bonding costs (Premium on CAR, Bid Security, Performance Security, Surety for advance payment, Warranty bond)
 - Contingencies, miscellaneous expenses and Contractor's Profit margin
- It is the responsibility of the Bidder to check the arithmetical computation provided therein.

Submitted by: _____
 (Name of Bidder / Company Name)

Prepared by: _____
 (Company Representative - Signature over printed name)

Address: _____

Telephone #: _____

Date: _____



Republic of the Philippines
SOCIAL SECURITY SYSTEM
 East Ave., Diliman, Quezon City

Project: SUPPLY, DELIVERY AND INSTALLATION OF MODULAR OFFICE SYSTEM AND FURNITURE FOR VARIOUS SSS BRANCH OFFICES
Location: Seaside Village Along Dela Rama rd, Jala Hilala St., CCP Complex, Bldg. 076, Pasay City

BILL OF QUANTITIES

ITEM	DESCRIPTION	QTY	UNIT	UNIT COST	VA (12%)	TOTAL COST
(A)	(B)	(C)	(D)	(E)	(F)	(G)
1. MODULAR OFFICE SYSTEM						
1. Branch Head Workstation (BHW)						
a.	1 pc.					
	Drivoped Free-Standing Executive Table, 1800mm L x 750mm D x 750mm H w/ 30mm Hs MDF Board Tabletop w/ Plastic Grannnel w/ Rotating Cover and 30mm Hs MDF Board Side Support in RFL Finish					
b.	1 pc.	1.0	ml			
	Side Return Table 1200mm L x 450mm D x 750mm H x 30mm Hs MDF Board Cantilevered w/ Plastic Grannnel w/ Rotating Cover, Galv. Metal Steel H Powder Coated Mesh Legs Support and Galv. Steel Meshy Panel in Powder Coated Mesh					
c.	Accessories					
1.	1 pc.					
	Center Drawer, 450mm W x 450mm D x 100mm H					
2.	1 pc.					
	Desktop Tray, Wood Finish					
2. Assistant Branch Head Workstation (ABHW)						
a. Modular Panels & Supports						
1.	1 pc.					
	Polaris Screen panel, Teal-tone, 1000mm W x 1200mm H x 40mm Hs with Powder Coated Aluminum Panel Backstay for Cable & Cables and Counter Glass					
2.	2 pc.					
	Polaris Screen panel, Teal-tone, 700mm W x 1200mm H x 40mm Hs with Powder Coated Aluminum Panel Backstay for Cable & Cables and Counter Glass					
3.	1 pc.					
	Polaris Screen Panel, Teal-tone, 450mm W x 1200mm H x 40mm Hs with Powder Coated Aluminum Panel Backstay for Cable & Cables and Counter Glass					
4.	2 pc.	1.0	ml			
	Aluminum End Ties, 1000mm H					
5.	1 pc.					
	Corner Pad, 3-way, 1000mm H					
b. Modular Worktop						
1.	1 pc.					
	Rectangular Worktop, 1200mm L x 450mm W x 30mm Hs MDF Board in RFL Finish, w/ 2pc. Plastic Grannnel w/ Rotating Cover					
2.	1 pc.					
	Rectangular Worktop, 1000mm L x 450mm W x 30mm Hs MDF Board in RFL Finish, w/ 2pc. Plastic Grannnel w/ Rotating Cover					
3.	1 pc.					
	Wood Meshy Panel, 1200mm W x 450mm H x 30mm Hs MDF Board in RFL Finish					
c.	Accessories					
1.	1 unit					
	Center Drawer, 450mm W x 450mm D x 100mm H					
2.	1 unit					
	Desktop Tray, Wood Finish					
3. Section Head Workstation (SHW-1)						
a. Modular Panels & Supports						
1.	3 pc.					
	Polaris Screen Panel, Teal-tone, 1000mm W x 1200mm H x 40mm Hs with Powder Coated Aluminum Panel Backstay for Cable & Cables					
2.	3 pc.					
	Polaris Screen Panel, Teal-tone, 450mm W x 1200mm H x 40mm Hs with Powder Coated Aluminum Panel Backstay for Cable & Cables					
3.	3 pc.					
	Polaris Screen Panel, Teal-tone, 400mm W x 1200mm H x 40mm Hs with Powder Coated Aluminum Panel Backstay for Cable & Cables					
4.	3 pc.					
	Polaris Screen Panel, Teal-tone, 1000mm W x 900mm H x 40mm Hs with Powder Coated Aluminum Panel Backstay for Cable & Cables					
5.	3 pc.					
	Polaris Screen Panel, Teal-tone, 450mm W x 900mm H x 40mm Hs with Powder Coated Aluminum Panel Backstay for Cable & Cables					
6.	3 pc.	3.0	mls			
	Aluminum End Ties, 1000mm H					
7.	3 pc.					
	Aluminum End Ties, 900mm H					
8.	3 pc.					
	Aluminum End Ties, 300mm H					
9.	10 pc.					
	Corner Pad, 3-way, 1000mm H					
10.	3 pc.					
	Corner Pad, 3-way, 900mm H					
b. Modular Worktop						
1.	3 pc.					
	Rectangular Worktop, 1200mm L x 450mm W x 30mm Hs MDF Board in RFL Finish, w/ 2pc. Plastic Grannnel w/ Rotating Cover					
2.	3 pc.					
	Rectangular Worktop, 1000mm L x 450mm W x 30mm Hs MDF Board in RFL Finish, w/ 2pc. Plastic Grannnel w/ Rotating Cover					
c.	Accessories					
1.	3 units					
	Center Drawer, 450mm W x 450mm D x 100mm H					
2.	3 units					
	Desktop Tray, Wood Finish					
4. Section Head Workstation (SHW-2)						
a. Modular Panels & Supports						
1.	1 pc.					
	Polaris Screen Panel, Teal-tone, 1000mm W x 1200mm H x 40mm Hs with Powder Coated Aluminum Panel Backstay for Cable & Cables					
2.	1 pc.					
	Polaris Screen Panel, Teal-tone, 450mm W x 1200mm H x 40mm Hs with Powder Coated Aluminum Panel Backstay for Cable & Cables					
3.	1 pc.					
	Polaris Screen Panel, Teal-tone, 400mm W x 1200mm H x 40mm Hs with Powder Coated Aluminum Panel Backstay for Cable & Cables					
4.	1 pc.					
	Polaris Screen Panel, Teal-tone, 1000mm W x 900mm H x 40mm Hs with Powder Coated Aluminum Panel Backstay for Cable & Cables					
5.	1 pc.					
	Polaris Screen Panel, Teal-tone, 450mm W x 900mm H x 40mm Hs with Powder Coated Aluminum Panel Backstay for Cable & Cables					
6.	1 pc.	1.0	ml			
	Aluminum End Ties, 1000mm H					
7.	3 pc.					
	Aluminum End Ties, 900mm H					
8.	1 pc.					
	Aluminum End Ties, 300mm H					
9.	1 pc.					
	Corner Pad, 3-way, 1000mm H					
10.	1 pc.					
	Corner Pad, 3-way, 900mm H					
11.	1 pc.					
	Corner Pad, 3-way, 1000mm H					
12.	1 pc.					
	Corner Pad, 3-way, 1000mm H					

ITEM	DESCRIPTION			QTY	UNIT	UNIT COST	VMF (137%)	TOTAL COST
(A)	(B)			(C)	(D)	(E)	(F)	(G)
	6. Module Worktop							
	1	1	pc.	Rectangular Worktop, 1800mm L x 600mm W x 30mm H, MDF Based In-HP, Finish, w/ (2)pc. Plastic Corners w/ Rotating Cover				
	2	1	pc.	Rectangular Worktop, 1000mm L x 600mm W x 30mm H, MDF Based In-HP, Finish, w/ (2)pc. Plastic Corners w/ Rotating Cover				
	6. Accessories							
	1	1	unit	Center Drawer, 600mm W x 600mm D x 160mm H				
	2	1	unit	Recessed Tray, Hard Plastic				
	7. Section Head Workstation (2W x 1)							
	a. Module Panels & Supports							
	1	1	pc.	Polarko Screen Panel, Two-tone, 1100mm W x 1200mm H x 60mm H, with Powder Coated Aluminum Panel Recess for Cable & Outlets				
	2	1	pc.	Polarko Screen Panel, Two-tone, 600mm W x 1200mm H x 60mm H, with Powder Coated Aluminum Panel Recess for Cable & Outlets				
	3	1	pc.	Polarko Screen Panel, Two-tone, 600mm W x 1200mm H x 60mm H, with Powder Coated Aluminum Panel Recess for Cable & Outlets				
	4	1	pc.	Polarko Screen Panel, Two-tone, 1800mm W x 600mm H x 60mm H, with Powder Coated Aluminum Panel Recess for Cable & Outlets				
	5	1	pc.	Polarko Screen Panel, Two-tone, 1000mm W x 1200mm H x 60mm H, with Powder Coated Aluminum Panel Recess for Cable & Outlets				
	6	1	pc.	Polarko Screen Panel, Two-tone, 600mm W x 600mm H x 60mm H, with Powder Coated Aluminum Panel Recess for Cable & Outlets	10	unit		
	7	1	pc.	Aluminum End Trim, 1200mm H				
	8	1	pc.	Aluminum End Trim, 600mm H				
	9	1	pc.	Aluminum End Trim, 300mm H				
	10	2	pc.	Corner Pad, 2-way, 1200mm H				
	11	1	pc.	Corner Pad, 2-way, 600mm H				
	b. Module Worktop							
	1	1	pc.	Rectangular Worktop, 1800mm L x 600mm W x 30mm H, MDF Based In-HP, Finish, w/ (2)pc. Plastic Corners w/ Rotating Cover				
	2	1	pc.	Rectangular Worktop, 1000mm L x 600mm W x 30mm H, MDF Based In-HP, Finish, w/ (2)pc. Plastic Corners w/ Rotating Cover				
	c. Accessories							
	1	1	unit	Center Drawer, 600mm W x 600mm D x 160mm H				
	2	1	unit	Recessed Tray, Hard Plastic				
	8. Section Head Workstation (2W x 2) Header							
	a. Module Panels & Supports							
	1	1	pc.	Polarko Screen Panel, Two-tone, 600mm W x 1200mm H x 60mm H, with Powder Coated Aluminum Panel Recess for Cable & Outlets				
	2	2	pc.	Polarko Screen Panel, Two-tone, 600mm W x 1200mm H x 60mm H, with Powder Coated Aluminum Panel Recess for Cable & Outlets				
	3	2	pc.	Polarko Screen Panel, Two-tone, 600mm W x 1200mm H x 60mm H, with Powder Coated Aluminum Panel Recess for Cable & Outlets				
	4	2	pc.	Polarko Screen Panel, Two-tone, 1800mm W x 1200mm H x 60mm H, with Powder Coated Aluminum Panel Recess for Cable & Outlets				
	5	2	pc.	Polarko Screen Panel, Two-tone, 1000mm W x 1200mm H x 60mm H, with Powder Coated Aluminum Panel Recess for Cable & Outlets				
	6	2	pc.	Polarko Screen Panel, Two-tone, 600mm W x 600mm H x 60mm H, with Powder Coated Aluminum Panel Recess for Cable & Outlets	10	unit		
	7	2	pc.	Aluminum End Trim, 1200mm H				
	8	2	pc.	Aluminum End Trim, 600mm H				
	9	2	pc.	Aluminum End Trim, 300mm H				
	10	2	pc.	Corner Pad, 2-way, 1200mm H				
	11	2	pc.	Corner Pad, 2-way, 600mm H				
	b. Module Worktop							
	1	2	pc.	Rectangular Worktop, 1800mm L x 600mm W x 30mm H, MDF Based In-HP, Finish, w/ (2)pc. Plastic Corners w/ Rotating Cover				
	2	2	pc.	Rectangular Worktop, 1000mm L x 600mm W x 30mm H, MDF Based In-HP, Finish, w/ (2)pc. Plastic Corners w/ Rotating Cover				
	c. Accessories							
	1	2	units	Center Drawer, 600mm W x 600mm D x 160mm H				
	2	2	units	Recessed Tray, Hard Plastic				
	9. Shelf Workstation (2W x 1)							
	a. Module Panels & Supports							
	1	12	pc.	Polarko Screen Panel, Aluminum, 1200mm H x 600mm W x 60mm H, with Powder Coated Aluminum Panel Recess for Cable & Outlets				
	2	24	pc.	Polarko Screen Panel, Two-tone, 600mm W x 600mm H x 60mm H, with Powder Coated Aluminum Panel Recess for Cable & Outlets	12.0	unit		
	3	24	pc.	Aluminum End Trim, 600mm H				
	4	24	pc.	Aluminum End Trim, 300mm H				
	5	24	pc.	Corner Pad, 2-way, 600mm H				
	b. Module Worktop							
	1	12	pc.	Rectangular Worktop, 1200mm L x 600mm W x 30mm H, MDF Based In-HP, Finish, w/ (2)pc. Plastic Corners w/ Rotating Cover				
	c. Accessories							
	1	12	units	Recessed Tray, Hard Plastic				
	10. Shelf Workstation (2W x 2) Header							
	a. Module Panels & Supports							
	1	8	pc.	Polarko Screen Panel, Two-tone, 1200mm W x 1200mm H x 60mm H, with Powder Coated Aluminum Panel Recess for Cable & Outlets				
	2	4	pc.	Polarko Screen Panel, Two-tone, 600mm W x 1200mm H x 60mm H, with Powder Coated Aluminum Panel Recess for Cable & Outlets				
	3	4	pc.	Polarko Screen Panel, Two-tone, 600mm W x 600mm H x 60mm H, with Powder Coated Aluminum Panel Recess for Cable & Outlets				
	4	4	pc.	Aluminum End Trim, 1200mm H				
	5	4	pc.	Aluminum End Trim, 600mm H				
	6	4	pc.	Aluminum End Trim, 300mm H				
	7	4	pc.	Corner Pad, 2-way, 1200mm H				
	8	4	pc.	Corner Pad, 2-way, 600mm H				
	b. Module Worktop							
	1	8	pc.	Rectangular Worktop, 1200mm L x 600mm W x 30mm H, MDF Based In-HP, Finish, w/ (2)pc. Plastic Corners w/ Rotating Cover				
	c. Accessories							
	1	8	units	Recessed Tray, Hard Plastic				

ITEM	DESCRIPTION	QTY	UNIT	UNIT CODE	UNIT PRICE	TOTAL COST
(A)	(B)	(C)	(D)	(E)	(F)	(G)
F. Staff Workstation (29'2 center)						
a. Module Panels & Supports						
1.	8	pcs.	Polaris Screen Panel, Two-tone, 1300mm W x 1300mm H x 30mm Hk with Powder Coated Aluminum Panel Backing for Cables & Outlets			
2.	8	PCS.	Polaris Screen panel, Two-tone, 600mm W x 1200mm H x 30mm Hk with Powder Coated Aluminum Panel Backing for Cables & Outlets			
3.	4	PCS.	Polaris Screen panel, Two-tone, 600mm W x 900mm H x 30mm Hk with Powder Coated Aluminum Panel Backing for Cables & Outlets			
4.	8	pcs.	Aluminum End Trim, 1300mm H	40	unit	-
5.	4	pcs.	Aluminum End Trim, 900mm H			
6.	4	pcs.	Aluminum End Trim, 600mm H			
7.	4	pcs.	Corner Pad, 3-way, 1300mm H			
8.	8	pcs.	Corner Pad, 4-way, 1300mm H			
b. Module Worktop						
1.	8	PCS.	Rectangular Worktop, 1300mm L x 600mm W x 30mm Hk, MDP Based in HP, Finish w/ 1 Spk, Plastic Granniel w/ Rotating Cover			
c. Accessories						
1.	8	units	Defused Tray, Head Pad(s)			
10. 10-Computer Workstation						
a. Module Panels & Supports						
1.	7	PCS.	Polaris Screen Panel, Two-tone, 1000mm W x 1000mm H x 30mm Hk with Powder Coated Aluminum Panel Backing for Cables & Outlets	1.0	unit	-
2.	2	pcs.	Corner Pad, 3-way, 1000mm H			
3.	2	pcs.	Aluminum End Trim, 1000mm H			
b. Module Worktop						
1.	14	PCS.	Rectangular Worktop, 700mm L x 600mm W x 30mm Hk, MDP Based in HP, Finish w/ 1 pc. Plastic Granniel w/ Rotating Cover			
c. Accessories						
1.	14	unit	CPU Holder			
2.	14	unit	Acrylic Plastic Divider			
3.	14	unit	Fullout Cover for Spline			
F. Desks & Tables						
a. Free-standing Plastic Table (PT) - 600mm L x 600mm D x 750mm H, MDP Based in HP, Finish w/ Plastic Granniel w/ Rotating Cover						
	10	unit				
b. Set of 4 - Modular Meeting Tables (600mm W x 1000mm L) supported by 48mm powder-coated tubular metal legs and bases						
	1.0	unit				
c. Round Conference Table, 900mm dia., MDP Based in HP, Finish						
	1.0	unit				
SUB-TOTAL - LCF I - MODULAR OFFICE SYSTEM						

ITEM	DESCRIPTION	QTY	UNIT	UNIT CODE	UNIT PRICE	TOTAL COST
G. BATHING FURNITURE						
1.	11 - Executive Chair, System, High-Back	2.00	unit			
2.	11 - Supervisor's Chair, System, Mid-Back w/ Armrest	3.00	unit			
3.	11 - Non-Supervisor's Chair/Soft Chair, 1-piece, Low Back w/ Armrest	47.00	unit			
4.	11 - Teller's High Chair w/ Backing, 2-piece, Mid-Back	1.00	unit			
5.	11 - Guard Chair 1, 3-piece, Mid-Back, Cantilever Type (For Executive) w/ Armrest	4.00	unit			
6.	11 - Guard Chair 2, 3-piece, Mid-Back w/ Armrest, w/ Room Condition	24.00	unit			
7.	11 - 4-Wheeler-Gang Chair, 200mm x 60mm x 60mm, Powder Coated Steel	17.00	unit			
SUB-TOTAL - LCF II - BATHING FURNITURE						

ITEM	DESCRIPTION	QTY	UNIT	UNIT CODE	UNIT PRICE	TOTAL COST
H. CONTRACT FURNITURE						
1. Reception Counter / Generalist Counter (29')						
a. Module Panels & Supports						
1.	12	pcs.	Side Support Panel, 600mm W x 1200mm H x 30mm Hk, MDP Based in HP, Finish			
2.	4	PCS.	Panel Modesty Panel, 1400mm W x 700mm H x 30mm Hk, Marble Physical w/ (Horizontal Strips w/ing) 1/2" Hk, MDP Based in HP, Finish			
3.	4	pcs.	Side Modesty Panel, 1000mm W x 700mm H x 30mm Hk, MDP Based in HP, Finish			
4.	12	pcs.	Side Support Panel, 600mm W x 700mm H x 30mm Hk, MDP Based in PVC Film Finish			
b. Module Worktop						
1.	4	PCS.	Rectangular Worktop, 1400mm L x 100mm W x 30mm Hk, w/ Synthetic Stone (Acrylic) w/ Plastic Granniel w/ Rotating Cover	40	unit	-
2.	4	PCS.	Rectangular Worktop, 1000mm L x 600mm W x 30mm Hk, w/ Synthetic Stone (Acrylic) w/ Plastic Granniel w/ Rotating Cover			
3.	4	PCS.	Undercounter Ledge, 800mm L x 200mm W x 30mm Hk, Marble Based in HP, Finish w/ Plastic Granniel w/ Rotating Cover			
c. Accessories						
1.	4	units	4-Layer Bullfinch Drawer, 400mm W x 400mm D x 30mm Hk, MDP Based in HP, Finish			
2.	4	units	100mm W x 100mm H 80 Logo in Stainless Steel Sheet			
3.	4	units	Defused Tray, Head Pad(s)			
2. Information Booth (Info)						
	1.0	unit	Drilluped, 1800mm L x 1000mm W x 1100mm H x 30mm Hk, Marble Physical Corncase w/ Bullfinch Drawers			
3. News-Writing Counter (NWC)						
	1.0	unit	600mm W x 1800mm L x 1000mm H Rectangular Shaped Writing Counter made of MDP Based (drilluped in HP, Finish and 48mm powder-coated tubular steel leg)			
4. Guard's Post						
	1.0	unit	Drilluped Guard Station in Marble Physical Corncase, HP, Finish w/ Bullfinch Drawers, Stainless Steel Steel Siding & Enclosed Logo			
5. Manager's Desk / Cabinet (MDC)						
	1.0	unit	1800mm W x 600mm D x 750 mm H Three Hk, Marble Physical in PVC Film Finish or Approved Equal			
SUB-TOTAL - LCF III - CONTRACT FURNITURE						

ITEM	DESCRIPTION	QTY	UNIT	UNIT COST	UNIT PRICE	TOTAL COST
(A)	(B)	(C)	(D)	(E)	(F)	(G)
ITEMS SHOWN, CASHED & DRAWN						
1.	Open Steel Shelving (OS) 4-Draw, 60" H	20.0	units		-	-
2.	Lateral filing Cabinet, 4-Draws	20.0	units		-	-
3.	Mobile Padded Drawer 3-Draws, 48" H x 36" W x 24" D x 24" D x 18" H	40.0	units		-	-
SUB-TOTAL (COTN - ITEMS SHOWN, CASHED & DRAWN)						-
GRAND TOTAL						-

GENERAL CONDITIONS

- For uniformity and evaluation purposes, a bidder shall adhere to the terms prescribed herein of BOD, specifically to the terms for completion, given quantity and inclusive pay items. Any deviation from the format shall be ground for disqualification of bid.
 - If up of required items listed in the BOD, failure to include any of the following shall mean outright disqualification since bid is considered nonresponsive:
 - * If item is given for free, indicate dash (-) zero (0) or free
 - * If the item is not applicable, indicate N/A
- Each bidder shall be provided with hard copy of the BOD Form (attached in the PEO) and an electronic copy for trade and e-procurement. The hard copy shall serve as the bidder's reference as to completeness of each item, quantity, formula, format, etc. in the BOD Form considering that the electronic copy is prone to alterations during scanning. Any discrepancy on the contents (specifically on the quantity and inclusive pay items) between the hard copy and electronic, the contents of the hard copy shall prevail.
- Bidder are not allowed to include any pay items that were not included in the form supplied. All quantities, in instances where necessary work items are inadvertently left out in BOD Form, a bidder should make a written query to the Bid and Award Committee so that the same shall be addressed in the Bid Bulletin which will be issued to all participating bidders.
- All documents must be signed, and each and every page thereof must be initialed by the duly authorized representative(s) of the bidder.
 - Full Price of the Purchase Item shall include the following:
 - Materials, fabrication and installation costs
 - Overhead expenses such as office expenses, supervision, transportation allowances, and bonding costs (Penetration CAN, Bid Security, Performance Security, Surety for advance payment, Warranty bond)
 - Contingencies, miscellaneous expenses and Contractor's profit margin
- It is the responsibility of the bidder to check the official BOD computer provided herein.

Submitted by: _____
 (Name of Bidder / Company Name)

Prepared by: _____
 (Company Representative - Signature over printed name)

Address: _____

Telephone #: _____

Date: _____



Republic of the Philippines
SOCIAL SECURITY SYSTEM
 East Ave., Diliman, Quezon City

Project: **SEFFY, DELIVERY AND INSTALLATION OF MODULAR OFFICE SYSTEM AND FURNITURE FOR VARIOUS SSS BRANCH OFFICES**
 Location: **SSS Marikina, 3F Beland, Gil Fernando Ave., cor Guerillo St, Marikina City**

BILL OF QUANTITIES

ITEM	DESCRIPTION	QTY	UNIT	UNIT COST	VR1 (12%)	TOTAL COST
(A)	(B)	(C)	(D)	(E)	(F)	(G)
1	MODULAR OFFICE SYSTEMS					
	1. Doctor Head Workstation (DHF-1)					
	a. Module Panels & Supports					
1.	4 ppa. Polaris Screen Panel, Two-tone, 1200mm W x 1200mm H x 40mm Hk with Powder Coated Aluminum Panel Backing for Cable & Outlets					
2.	4 ppa. Polaris Screen Panel, Two-tone, 600mm W x 1200mm H x 40mm Hk with Powder Coated Aluminum Panel Backing for Cable & Outlets					
3.	4 ppa. Polaris Screen Panel, Two-tone, 600mm W x 1200mm H x 40mm Hk with Powder Coated Aluminum Panel Backing for Cable & Outlets					
4.	4 ppa. Polaris Screen Panel, Monochrome, 1500mm W x 700mm H x 40mm Hk with Powder Coated Aluminum Panel Backing for Cable & Outlets					
5.	4 ppa. Polaris Screen Panel, Two-tone, 600mm W x 900mm H x 40mm Hk with Powder Coated Aluminum Panel Backing for Cable & Outlets					
6.	4 ppa. Aluminum End Ties, 1200mm H	40	sets			
7.	4 ppa. Aluminum End Ties, 900mm H					
8.	4 ppa. Aluminum End Ties, 600mm H					
9.	4 ppa. Aluminum End Ties, 1800mm H					
10.	12 ppa. Corner Pad, 3-way, 1200mm H					
11.	4 ppa. Corner Pad, 3-way, 900mm H					
	b. Module Worktop					
1.	4 ppa. Rectangular Worktop, 1500mm L x 600mm W x 30mm Hk, MDF Board In-PP, Finish, w/ (2)pa. Plastic Corners w/ Rabbeting Cover					
2.	4 ppa. Rectangular Worktop, 1200mm L x 600mm W x 30mm Hk, MDF Board In-PP, Finish, w/ (2)pa. Plastic Corners w/ Rabbeting Cover					
	c. Accessories					
1.	4 units. Cable Chassis, 600mm W x 600mm D x 160mm H					
2.	4 units. Desktop Tray, Hard Plastic					
	2. Doctor's Workstation (DWO)					
	a. Module Panels & Supports					
1.	2 ppa. Polaris Screen Panel, Two-tone, 1200mm W x 1200mm H x 40mm Hk with Powder Coated Aluminum Panel Backing for Cable & Outlets					
2.	4 ppa. Polaris Screen Panel, Two-tone, 600mm W x 1200mm H x 40mm Hk with Powder Coated Aluminum Panel Backing for Cable & Outlets					
3.	1 ppa. Polaris Screen Panel, Two-tone, 700mm W x 1200mm H x 40mm Hk with Powder Coated Aluminum Panel Backing for Cable & Outlets					
4.	2 ppa. Polaris Screen Panel, Two-tone, 600mm W x 1200mm H x 40mm Hk with Powder Coated Aluminum Panel Backing for Cable & Outlets					
5.	2 ppa. Polaris Screen Panel, Monochrome, 1500mm W x 700mm H x 40mm Hk with Powder Coated Aluminum Panel Backing for Cable & Outlets					
6.	2 ppa. Polaris Screen Panel, Two-tone, 600mm W x 900mm H x 40mm Hk with Powder Coated Aluminum Panel Backing for Cable & Outlets					
7.	2 ppa. Aluminum End Ties, 1200mm H	20	sets			
8.	2 ppa. Aluminum End Ties, 900mm H					
9.	2 ppa. Aluminum End Ties, 1800mm H					
10.	4 ppa. Corner Pad, 3-way, 1200mm H					
11.	2 ppa. Corner Pad, 3-way, 900mm H					
	b. Module Worktop					
1.	2 ppa. Rectangular Worktop, 1500mm L x 600mm W x 30mm Hk, MDF Board In-PP, Finish, w/ (2)pa. Plastic Corners w/ Rabbeting Cover					
2.	2 ppa. Rectangular Worktop, 1200mm L x 600mm W x 30mm Hk, MDF Board In-PP, Finish, w/ (2)pa. Plastic Corners w/ Rabbeting Cover					
	c. Accessories					
1.	2 units. Cable Chassis, 600mm W x 600mm D x 160mm H					
2.	2 units. Desktop Tray, Hard Plastic					
	3. Staff Workstation (SW-1)					
	a. Module Panels & Supports					
1.	24 ppa. Polaris Screen Panel, Monochrome, 1200mm W x 700mm H x 40mm Hk with Powder Coated Aluminum Panel Backing for Cable & Outlets					
2.	32 ppa. Polaris Screen Panel, Two-tone, 600mm W x 900mm H x 40mm Hk with Powder Coated Aluminum Panel Backing for Cable & Outlets					
3.	32 ppa. Aluminum End Ties, 900mm H	24.0	sets			
4.	32 ppa. Aluminum End Ties, 1800mm H					
5.	32 ppa. Corner Pad, 3-way, 900mm H					
	b. Module Worktop					
1.	24 ppa. Rectangular Worktop, 1200mm L x 600mm W x 30mm Hk, MDF Board In-PP, Finish, w/ (2)pa. Plastic Corners w/ Rabbeting Cover					
	c. Accessories					
1.	24 units. Desktop Tray, Hard Plastic					
	4. Computer Workstation (CW-WMG)					
	a. Free-Standing Computer Table (FST), 1000mm L x 600mm D x 740mm H x 30mm Hk, MDF Board In-PP, Finish, Post-Formed Panel & Back Edges w/ Co. 18 Legs Support/ Powder Coated Finish w/ Integrated Cable Management Channel w/ Plastic Corners w/ Rabbeting Cover	1.0	units			
	5. IC Capture Workstation					
	a. Module Panels & Supports					
1.	14 ppa. Polaris Screen Panel, Two-tone, 1000mm W x 1800mm H x 40mm Hk with Powder Coated Aluminum Panel Backing for Cable & Outlets	1.0	sets			
2.	4 ppa. Corner Pad, 3-way, 1800mm H					
3.	4 ppa. Aluminum End Ties, 1800mm H					
	6. E-Reader Workstation					
	a. Module Panels & Supports					
1.	28 ppa. Polaris Screen Panel, Two-tone, 600mm W x 1180mm H x 30mm Hk with Powder Coated Aluminum Panel Backing for Cable & Outlets					

ITEM	DESCRIPTION			QTY	UNIT	UNIT COST	VAL (17%)	TOTAL COST
(A)	(B)			(C)	(D)	(E)	(F)	(G)
	1.	14	pcs.	Polaris Screen Panel, Tempered, 750mm W x 1100mm H x 30mm TH with Powder Coated Aluminium Panel Backing for Cable & Outlet				
	2.	28	pcs.	Aluminium End Trim, 1100mm H				
	3.	28	pcs.	Corner Post, 2-way, 1100mm H	14.0	unit	-	-
	b. Module Worktop							
	1.	14	pcs.	Rectangular Worktop, 750mm L x 800mm W x 30mm TH, MDP Based in HPL Finish w/ 1 pc. Plastic Corner/w/ Rounding Cover				
	c. Accessories							
	1.	14	unit	CPD Holder				
	2.	14	unit	Acrylic Plastic Divider				
	3.	14	unit	Full-rod Drawer for Storage				
	7. Desk & Tables							
	a.	Free Standing White Table (RT) - 800mm L x 400mm D x 740mm H MDP Based in HPL Finish w/ Plastic Corner/w/ Rounding Cover			1.0	unit	-	-
	b.	Executive Conference Table (2-seater, fixed Edge w/ Wire Management) MDP Based in HPL Finish			1.0	unit	-	-
	c.	Round Conference Table 700mm dia. MDP Based in HPL Finish			1.0	unit	-	-
	SUB-TOTAL - LOT I - ADDITIONAL OFFICE SUPPLIES							-
II	MEETING FURNITURE							
	1.	22	pc	Superior's Chair, 1-piece, Mesh Back w/ Armrest	6.00	unit	-	-
	2.	22	pc	Non-Superior's Chair/Soft Chair, 1-piece, Low Back w/ Armrest	6.00	unit	-	-
	3.	24	pc	Teller's High Chair w/ Footing, 2-piece, Mesh Back	4.00	unit	-	-
	4.	24	pc	Round Chair 2, 2-piece, Mesh Back w/ Armrest, w/ Room Cushion	17.00	unit	-	-
	5.	17	pc	4-Seater Gang Chair, 150mm x 60mm x 60mm, Powder Coated Steel	9.0	unit	-	-
	6.	17	pc	4-Seater Gang Chair, 200mm x 60mm x 60mm, Powder Coated Steel	20.00	unit	-	-
	SUB-TOTAL - LOT II - MEETING FURNITURE							-
III	CONTACT FURNITURE							
	1. Reception Counter / Memorial Counter (2x2)							
	a. Module Panels & Supports							
	1.	12	pcs.	Side Support Panel, 800mm W x 1200mm H x 30mm TH, MDP Based in HPL Finish				
	2.	4	PCS	Panel Modesty Panel, 1400mm W x 700mm H x 30mm TH, Marine Physical w/ Horizontal Strips using 1/2" TH MDP Based in HPL Finish				
	3.	4	pcs.	Side Modesty Panel, 1000mm W x 700mm H x 30mm TH, MDP Based in HPL Finish				
	4.	12	pcs.	Side Support Panel, 400mm W x 700mm H x 30mm TH, MDP Based in PVC Film Finish				
	b. Module Worktop							
	1.	4	pcs.	Rectangular Worktop, 1400mm L x 1000mm W x 30mm TH, w/ Synthetic Stone (Acrylic) w/ Plastic Corner/w/ Rounding Cover	40	unit	-	-
	2.	4	pcs.	Rectangular Worktop, 1000mm L x 400mm W x 30mm TH, w/ Synthetic Stone (Acrylic) w/ Plastic Corner/w/ Rounding Cover				
	3.	4	PCS	Undercounter Ledge, 800mm L x 300mm W x 30mm TH, Marble Based in HPL Finish w/ Plastic Corner/w/ Rounding Cover				
	c. Accessories							
	1.	4	unit	4-Way Built-in Drawer, 400mm W x 400mm D x 30mm TH MDP Based in HPL Finish				
	2.	4	unit	100mm W x 100mm H 100 Logo in Stainless Steel Sheet				
	3.	4	unit	Embossed Tray, Hard Plastic				
	2. Information Booth (Info)							
	Drop-in, 1800mm L x 1000mm W x 1100mm H x 30mm TH Marine Physical Corianse w/ Built-in Drawers			1.0	unit	-	-	-
	3. Guard's Post							
	Drop-in Guard Station in Marine Physical Corianse, HPL Finish w/ Built-in Drawers, Stainless Steel Siding & Embossed Logo			1.0	unit	-	-	-
	SUB-TOTAL - LOT III - CONTACT FURNITURE							-
IV	DESK, DRAWER, CABINETS & DRAWERS							
	1. Open Steel Drawers (OSD) - 4-layer, Co. II			37.0	unit	-	-	-
	2. Mobile Prolonged Drawers - 2-Drawers, 400mm W x 360mm D x 460mm H			33.0	unit	-	-	-
	SUB-TOTAL - LOT IV - DESK, DRAWER, CABINETS & DRAWERS							-
	GRAND TOTAL							-

GENERAL CONDITIONS

- For uniformity and evaluation purposes, a bidder shall adhere to the herein prescribed format of BOC, specifically in the format for computation, given quantity and include pay items. Any deviation from the format shall be a ground for disqualification of bid.
 - If up of required items listed in the BOC, bidder to indicate any of the following shall mean outright disqualification since bid is considered non-responsive:
 - * If item is given for free, indicate dash (-), zero (0) or free
 - * If the item is not applicable, indicate N/A
- Each bidder shall be provided with hard copy of the BOC Form (attached in the BIDD) and an electronic copy for table and easier encoding. The hard copy shall serve as the bidder's reference as to completeness of work items, quantity, format, format, etc. in the BOC Form considering that the electronic copy is prone to alterations during encoding. Any discrepancy on the contents (quantity and include pay items) between the hard copy and electronic, the contents of the hard copy shall prevail.
- Bidder are not allowed to include any pay items that were not included in the form supplied BOC of Quantities. In instances where necessary work items are inadvertently left out in BOC Form, a bidder should make a written query to the Bids and Awards Committee so that the same shall be addressed in the Bid Bulletin which will be issued to all participating bidders.
- All documents must be signed, and each and every page thereof must be initialed by the duly authorized representative(s) of the Bidder.
- Unit Price of the Furniture item shall include the following:
 - Materials, fabrication and installation cost
 - Overhead expenses such as office expenses, supervision, transportation allowances, and training costs (Premium on CMI, Bid Security, Performance Security, Surety for advance payment, Warranty bond)
 - Contingencies, miscellaneous expenses and Contractor's Profit margin
- It is the responsibility of the Bidder to check the official computer provided therein.

Submitted by: _____
 (Name of Bidder / Company Name)
 Prepared by: _____
 (Company Representative - Signature over printed name)
 Address: _____
 Telephone #: _____
 Date: _____



Republic of the Philippines
SOCIAL SECURITY SYSTEM
 East Ave., Diliman, Quezon City

Project: **SEPCO, DELIVERY AND INSTALLATION OF MODULAR OFFICE SYSTEM AND FURNITURE FOR VARIOUS SSS BRANCHES**
 Location: **SSS Tagaytay, UGF, Primark Town Center - Tagaytay, Mahalika-East, Tagaytay City**

BILL OF QUANTITIES

ITEM	DESCRIPTION	QTY	UNIT	UNIT COST	VAJ (12%)	TOTAL COST
(A)	(B)	(C)	(D)	(E)	(F)	(G)
1. MODULAR OFFICE SYSTEMS						
1. Branch Head Workstation (BHW)						
a.	1	pc.	Divided Free-Standing Executive Table, 1800mm L x 750mm D x 750mm H w/ 30mm Hs MDF Board (tabletop w/ Plastic Coated w/ Rotating Cover and 30mm Hs MDF Board Side Support in HPL Finish	1.0	-	-
b.	1	pc.	Side Return Table 1200mm L x 450mm D x 750mm H x 30mm Hs MDF Board (tabletop w/ Plastic Coated w/ Rotating Cover, Co. 18 Mahal Steel in Powder Coated Finish Legs Support and Co. 21 Steel Meshy Panel in Powder Coated Finish	1.0	-	-
c.	Accessories					
1.	1	pc.	Center Drawer, 360mm W x 450mm D x 60mm H			
2.	1	pc.	Recessed Tray, Hard Plastic			
2. Assistant Branch Head Workstation (ABHW)						
a.	Module Panels & Supports					
1.	1	pc.	Polka Screen panel, Teal-tone, 1200mm W x 1800mm H x 30mm Hs with Powder Coated Aluminum Panel Backery for Cable & Outlets and Quarter Glass			
2.	1	pc.	Polka Screen panel, Teal-tone, 700mm W x 1800mm H x 30mm Hs with Powder Coated Aluminum Panel Backery for Cable & Outlets and Quarter Glass			
3.	1	pc.	Polka Screen Panel, Teal-tone, 450mm W x 1800mm H x 30mm Hs with Powder Coated Aluminum Panel Backery for Cable & Outlets and Quarter Glass			
4.	2	pc.	Aluminum End Ties, 1800mm H	1.0	-	-
5.	1	pc.	Corner Pad, 2-way, 1800mm H			
b.	Module Worktop					
1.	1	pc.	Rectangular Worktop, 1800mm L x 450mm W x 30mm Hs MDF Board in HPL Finish, w/ 2 Spa, Plastic Coated w/ Rotating Cover			
2.	1	pc.	Rectangular Worktop, 1200mm L x 450mm W x 30mm Hs MDF Board in HPL Finish, w/ 2 Spa, Plastic Coated w/ Rotating Cover			
3.	1	pc.	Panel Meshy Panel, 1800mm W x 450mm H x 30mm Hs MDF Board in HPL Finish			
c.	Accessories					
1.	1	unit	Center Drawer, 360mm W x 450mm D x 60mm H			
2.	1	unit	Recessed Tray, Hard Plastic			
3. Section Head Workstation (SHW-1)						
a.	Module Panels & Supports					
1.	3	pc.	Polka Screen Panel, Teal-tone, 1200mm W x 1200mm H x 30mm Hs with Powder Coated Aluminum Panel Backery for Cable & Outlets			
2.	3	pc.	Polka Screen Panel, Teal-tone, 600mm W x 1200mm H x 30mm Hs with Powder Coated Aluminum Panel Backery for Cable & Outlets			
3.	3	pc.	Polka Screen Panel, Teal-tone, 450mm W x 1200mm H x 30mm Hs with Powder Coated Aluminum Panel Backery for Cable & Outlets			
4.	3	pc.	Polka Screen Panel, Teal-tone, 1800mm W x 700mm H x 30mm Hs with Powder Coated Aluminum Panel Backery for Cable & Outlets			
5.	3	pc.	Polka Screen Panel, Teal-tone, 360mm W x 900mm H x 30mm Hs with Powder Coated Aluminum Panel Backery for Cable & Outlets			
6.	3	pc.	Aluminum End Ties, 1200mm H	3.0	-	-
7.	3	pc.	Aluminum End Ties, 900mm H			
8.	3	pc.	Aluminum End Ties, 450mm H			
9.	3	pc.	Aluminum End Ties, 1800mm H			
10.	3	pc.	Corner Pad, 2-way, 1200mm H			
11.	3	pc.	Corner Pad, 2-way, 900mm H			
b.	Module Worktop					
1.	3	pc.	Rectangular Worktop, 1800mm L x 450mm W x 30mm Hs MDF Board in HPL Finish, w/ 2 Spa, Plastic Coated w/ Rotating Cover			
2.	3	pc.	Rectangular Worktop, 1200mm L x 450mm W x 30mm Hs MDF Board in HPL Finish, w/ 2 Spa, Plastic Coated w/ Rotating Cover			
c.	Accessories					
1.	3	units	Center Drawers, 360mm W x 450mm D x 60mm H			
2.	3	units	Recessed Tray, Hard Plastic			
4. Section Head Workstation (SHW-2) - Doctor's Workstation						
a.	Module Panels & Supports					
1.	2	pc.	Polka Screen Panel, Teal-tone, 1200mm W x 1200mm H x 30mm Hs with Powder Coated Aluminum Panel Backery for Cable & Outlets			
2.	2	pc.	Polka Screen Panel, Teal-tone, 450mm W x 1200mm H x 30mm Hs with Powder Coated Aluminum Panel Backery for Cable & Outlets			
3.	2	pc.	Polka Screen Panel, Teal-tone, 450mm W x 1200mm H x 30mm Hs with Powder Coated Aluminum Panel Backery for Cable & Outlets			
4.	2	pc.	Polka Screen Panel, Teal-tone, 1800mm W x 900mm H x 30mm Hs with Powder Coated Aluminum Panel Backery for Cable & Outlets			
5.	2	pc.	Polka Screen Panel, Teal-tone, 360mm W x 900mm H x 30mm Hs with Powder Coated Aluminum Panel Backery for Cable & Outlets			
6.	2	pc.	Polka Screen Panel, Teal-tone, 600mm W x 1200mm H x 30mm Hs with Powder Coated Aluminum Panel Backery for Cable & Outlets			
7.	2	pc.	Polka Screen Panel, Teal-tone, 450mm W x 1200mm H x 30mm Hs with Powder Coated Aluminum Panel Backery for Cable & Outlets	2.0	-	-
8.	4	pc.	Aluminum End Ties, 1200mm H			
9.	2	pc.	Aluminum End Ties, 900mm H			
10.	2	pc.	Aluminum End Ties, 1800mm H			
11.	4	pc.	Corner Pad, 2-way, 1200mm H			
12.	2	pc.	Corner Pad, 2-way, 900mm H			

ITEM	DESCRIPTION			QTY	UNIT	UNIT COST	VAI (17%)	TOTAL COST
(A)	(B)			(C)	(D)	(E)	(F)	(G)
	6. Module Worktop							
	1.	2	mm	Rectangular Worktop, 1000mm L x 600mm W x 30mm H, MDF Based in HPL, Finish w/ 2-ply, Plastic Coated w/ Rotating Cover				
	2.	2	mm	Rectangular Worktop, 1000mm L x 600mm W x 30mm H, MDF Based in HPL, Finish w/ 2-ply, Plastic Coated w/ Rotating Cover				
	6. Accessories							
	1.	2	units	Circle Drawer, 600mm W x 600mm D x 100mm H				
	2.	2	units	Defaced Tray, Hard Plastic				
	7. Staff Workstation (2P-1)							
	a. Module Panels & Supports							
	1.	11	mm	Polka Screen Panel, Mainframe, 1000mm W x 700mm H x 60mm H with Powder Coated Aluminium Panel Backing for Cable & Cables				
	2.	22	mm	Polka Screen panel, Two-tone, 600mm W x 1000mm H x 60mm H with Powder Coated Aluminium Panel Backing for Cable & Cables				
	3.	22	mm	Aluminium End Trim, 600mm H	11.0	unit		
	4.	22	mm	Aluminium End Trim, 1800mm H				
	5.	22	mm	Corner Post, 2-way, 600mm H				
	b. Module Worktop							
	1.	11	mm	Rectangular Worktop, 1000mm L x 600mm W x 30mm H, MDF Based in HPL, Finish w/ 2-ply, Plastic Coated w/ Rotating Cover				
	c. Accessories							
	1.	11	units	Defaced Tray, Hard Plastic				
	8. Staff Workstation (2P-2)							
	a. Module Panels & Supports							
	1.	18	mm	Polka Screen Panel, Two-tone, 1000mm W x 1000mm H x 60mm H with Powder Coated Aluminium Panel Backing for Cable & Cables				
	2.	36	mm	Polka Screen panel, Two-tone, 600mm W x 1000mm H x 60mm H with Powder Coated Aluminium Panel Backing for Cable & Cables				
	3.	36	mm	Aluminium End Trim, 600mm H	18.0	unit		
	4.	36	mm	Aluminium End Trim, 600mm H				
	5.	36	mm	Corner Post, 2-way, 1000mm H				
	b. Module Worktop							
	1.	18	mm	Rectangular Worktop, 1000mm L x 600mm W x 30mm H, MDF Based in HPL, Finish w/ 2-ply, Plastic Coated w/ Rotating Cover				
	c. Accessories							
	1.	18	units	Defaced Tray, Hard Plastic				
	9. Computer Workstation (For 6M2)							
	a. Free-standing Computer Table (F1) - 1000mm L x 600mm D x 700mm H x 60mm H, MDF Based in HPL, Finish w/ Plastic Coated w/ Rotating Cover			20	unit			
	b. Free-standing Computer Table (F2) - 1000mm L x 600mm D x 700mm H x 60mm H, MDF Based in HPL, Finish w/ Plastic Coated w/ Rotating Cover			20	unit			
	c. Set of 4 - Module Seating Tables (600mm W x 1000mm L) supported by 60mm powder-coated tubular metal legs and bases			1.0	unit			
	d. Round Conference Table, 600mm dia, MDF Based in HPL, Finish			1.0	unit			
	SUB-TOTAL - LOT 1 - MODULAR OFFICE SYSTEM							
	10. METAL FURNITURE							
	1. 2P - Executive Chair, 5-piece, High Back			1.00	unit			
	2. 2P - Supervisor's Chair, 5-piece, Mid Back w/ Armrest			8.00	unit			
	3. 2P - Non-Supervisor's Chair/Staff Chair, 5-piece, Low Back w/ Armrest			87.00	unit			
	4. 2P - Teller's High Chair w/ Footing, 2-piece, Mid Back			6.00	unit			
	5. 2P - Guest Chair 1, 2-piece, Mid Back, Curved/Level Top (For Executive) w/ Armrest			2.00	unit			
	6. 2P - Guest Chair 2, 2-piece, Mid Back w/ Armrest, w/ Room Divider			30.00	unit			
	7. 2P - 4-Drawer Gang Chair, 250mm x 600mm 60mm, Powder Coated Steel			2.0	unit			
	8. 2P - 6-Drawer Gang Chair, 250mm x 600mm 60mm, Powder Coated Steel			12.00	unit			
	SUB-TOTAL - LOT 2 - METAL FURNITURE							
	11. CONTRACT FURNITURE							
	1. Reception Counter / Generalist Counter (2P-1)							
	a. Module Panels & Supports							
	1.	14	mm	Side Support Panel, 600mm W x 1000mm H x 30mm H, MDF Based in HPL, Finish				
	2.	7	mm	Front Modesty Panel, 1400mm W x 700mm H x 30mm H, Marine Plywood w/ Horizontal Strips using 1/2" HPL MDF Based in HPL, Finish				
	3.	7	mm	Side Modesty Panel, 1000mm W x 700mm H x 30mm H, MDF Based in HPL, Finish				
	4.	14	mm	Side Support Panel, 600mm W x 700mm H x 30mm H, MDF Based in PVC Film Finish				
	b. Module Worktop							
	1.	7	mm	Rectangular Worktop, 1400mm L x 700mm W x 30mm H, w/ Synthetic Stone (Acrylic) w/ Plastic Coated w/ Rotating Cover	7.0	unit		
	2.	7	mm	Rectangular Worktop, 1000mm L x 600mm W x 30mm H, w/ Synthetic Stone (Acrylic) w/ Plastic Coated w/ Rotating Cover				
	3.	7	mm	Undercounter ledge, 600mm L x 200mm W x 20mm H, Particle Board in HPL, Finish w/ Plastic Coated w/ Rotating Cover				
	c. Accessories							
	1.	7	units	4-Way Bull-Horn Drawer, 600mm W x 600mm D x 30mm H, MDF Based in HPL, Finish				
	2.	7	units	1200mm W x 1000mm H 000 Legs in Stainless Steel Steel				
	3.	7	units	Defaced Tray, Hard Plastic				
	2. Teller's Booth							
	3000mm D x 1000mm L x 1800mm H Single Booth, 60mm H, MDF in HPL, Finish with Door, Side Drawer and Cash Drawer				unit	121,000.00	14,640.00	
	3. Information Booth (Info)							
	Unfinished, 1800mm L x 1000mm W x 1100mm H x 60mm H, Marine Plywood Coated w/ Bull-Horn Drawers			1.0	unit			

ITEM	DESCRIPTION	QTY	UNIT	UNIT COST	VAR (17%)	TOTAL COST
(A)	(B)	(C)	(D)	(E)	(F)	(G)
	B. Non-Wiring Cables (NWC)					
	400mm W x 1000mm L x 1000mm H Rectangular Shaped Wiring Cables made of MDF board (belong to NWC, NDB and 400mmx1000mmx1000mm (belong to))	30	units		-	-
	B. Guard's Post					
	Drill-pipe Guard Station in Marine Physical Canvas, 400 mm Width w/ 400mm Diameter, Stainless Steel Steel Siding & Reinforced Logo	10	unit		-	-
	B. Manager's Desk Cabinet (MDC)					
	1000mm W x 600mm D x 750mm H Three (3) Marine Physical in PVC Film Mesh or Approved Equal	10	unit		-	-
SUB-TOTAL - LOT II - CONTRACT FURNISH						-

NO	ITEM, QUANTITY, CATEGORY & DRAWING	QTY	UNIT	UNIT COST	VAR	TOTAL COST
1	Open Steel Shelving (OSS) 400mm W x 1000mm H	30.0	units		-	-
2	Lateral Railing Cabinet 400mm W x 1000mm H	10.0	units		-	-
3	Mobile Reinforced Drawers 3-Drawers, 400mm W x 600mm D x 750mm H	10.0	units		-	-
SUB-TOTAL - LOT IV - ITEM, QUANTITY, CATEGORY & DRAWING						-

NO	PERIOD COVERED including Labor and Other Expenses	QTY	UNIT	UNIT COST	VAR	TOTAL COST
GRAND TOTAL						-

GENERAL CONDITIONS

- For uniformity and evaluation purposes, a Bidder shall adhere to the format prescribed format of BOC, specifically in the format for computation, given quantity and inclusive pay items. Any deviation from the format shall be a ground for disqualification of bid.
 - Fill up of required items/field in the BOC. Failure to indicate any of the following shall mean outright disqualification since bid is considered non-responsive:
 - * If item is given for free, indicate dash (-), zero (0) or free
 - * If the item is not applicable, indicate N/A
- Each Bidder shall be provided with hard copy of the BOC Form (attached in the PIC) and an electronic copy for later and easier encoding. The hard copy shall serve as the Bidder's reference as to completeness of each item, quantity, format, etc. in the BOC Form considering that the electronic copy is prone to alterations during encoding. Any discrepancy on the contents (quantity and inclusive pay items) between the hard copy and electronic, the contents of the hard copy shall prevail.
- Bidder are not allowed to include any pay items that were not indicated in the form supplied BOC of Quantities. In instances where necessary work items are inadvertently left out in BOC Form, a Bidder should make a written query to the Bids and Awards Committee so that the same shall be addressed in the Bid Bulletin which will be issued to all participating bidders.
- All documents must be signed, and each and every page thereof must be initialed by the duly authorized representative(s) of the Bidder.
- Unit Price of the Purchase Item shall include the following:
 - Materials, fabrication and installation costs
 - Overhead expenses such as office expenses, supervision, transportation allowances, and training costs (Premium on CMA, Bid Security, Performance Security, Surety for advance payment, Warranty bond)
 - Contingencies, miscellaneous expenses and Contractor's profit margin
- It is the responsibility of the Bidder to check the aforementioned computation provided herein.

Submitted by: _____
(Name of Bidder / Company Name)

Prepared by: _____
(Company Representative - Signature over printed name)

Address: _____

Telephone #: _____

Date: _____



Republic of the Philippines
SOCIAL SECURITY SYSTEM
 East Ave., Diliman, Quezon City

Project: **SEPPY, DELIVERY AND INSTALLATION OF MODULAR OFFICE SYSTEM AND FURNITURE FOR VARIOUS SSS BRANCH OFFICES**
 Location: **SSS Rosario, G/F & 3/F 348 Abutin Building, Tejero Convention, Gen. Tioa Drive, Rosario, Cavite**

BILL OF QUANTITIES

ITEM	DESCRIPTION	QTY	UNIT	UNIT COST	VAT (12%)	TOTAL COST
(A)	(B)	(C)	(D)	(E)	(F)	(G)
1	MODULAR OFFICE SYSTEM					
	1. Branch Head Workstation (BHW)					
a.	1 pc. Driveway Free-Standing Executive Table, 1800mm L x 750mm D x 750mm H in 30mm BS MDF Board (tabletop w/ Plastic Grannell w/ Rotating Cover and 30mm BS MDF faced Side Support in HPL Finish					
b.	1 pc. Side Return Table 1200mm L x 600mm D x 750mm H x 30mm BS MDF Board (tabletop w/ Plastic Grannell w/ Rotating Cover, Galv. Metal Steel in Powder Coated Finish Legs Support and Galv. Steel Modesty Panel in Powder Coated Finish	1.0	pc.			
c.	Accessories					
1.	1 pc. Center Drawer, 600mm W x 400mm D x 100mm H					
2.	1 pc. Detached Tray, Head Panel					
	2. Assistant Branch Head Workstation (ABHW)					
a.	Module Panels & Supports					
1.	1 pc. Polaris Screen panel, Two-tone, 1000mm W x 1800mm H x 40mm BS with Powder Coated Aluminum Panel Backery for Cable & Outlets and Counter Glass					
2.	2 pc. Polaris Screen panel, Two-tone, 700mm W x 1800mm H x 40mm BS with Powder Coated Aluminum Panel Backery for Cable & Outlets and Counter Glass					
3.	1 pc. Polaris Screen Panel, Two-tone, 600mm W x 1800mm H x 40mm BS with Powder Coated Aluminum Panel Backery for Cable & Outlets and Counter Glass					
4.	2 pc. Aluminum End Ties, 1000mm H	1.0	pc.			
5.	1 pc. Corner Pad, 2-way, 1000mm H					
b.	Module Worktop					
1.	1 pc. Rectangular Worktop, 1800mm L x 600mm W x 30mm BS MDF Board in HPL Finish, w/ 2 pcs. Plastic Grannell w/ Rotating Cover					
2.	1 pc. Rectangular Worktop, 1200mm L x 600mm W x 30mm BS MDF Board in HPL Finish, w/ 2 pcs. Plastic Grannell w/ Rotating Cover					
3.	1 pc. Front Modesty Panel, 1800mm W x 600mm H x 20mm BS MDF Board in HPL Finish					
c.	Accessories					
1.	1 unit Center Drawer, 600mm W x 400mm D x 100mm H					
2.	1 unit Detached Tray, Head Panel					
	3. Section Head Workstation (SHW-1)					
a.	Module Panels & Supports					
1.	8 pc. Polaris Screen Panel, Two-tone, 1000mm W x 1800mm H x 40mm BS with Powder Coated Aluminum Panel Backery for Cable & Outlets					
2.	8 pc. Polaris Screen Panel, Two-tone, 600mm W x 1800mm H x 40mm BS with Powder Coated Aluminum Panel Backery for Cable & Outlets					
3.	8 pc. Polaris Screen Panel, Two-tone, 600mm W x 1800mm H x 40mm BS with Powder Coated Aluminum Panel Backery for Cable & Outlets					
4.	8 pc. Polaris Screen Panel, Two-tone, 1000mm W x 700mm H x 40mm BS with Powder Coated Aluminum Panel Backery for Cable & Outlets					
5.	8 pc. Polaris Screen Panel, Two-tone, 600mm W x 900mm H x 40mm BS with Powder Coated Aluminum Panel Backery for Cable & Outlets					
6.	8 pc. Aluminum End Ties, 1000mm H	1.0	pc.			
7.	8 pc. Aluminum End Ties, 900mm H					
8.	8 pc. Aluminum End Ties, 600mm H					
9.	8 pc. Aluminum End Ties, 1800mm H					
10.	18 pc. Corner Pad, 2-way, 1000mm H					
11.	8 pc. Corner Pad, 2-way, 900mm H					
b.	Module Worktop					
1.	8 pc. Rectangular Worktop, 1800mm L x 600mm W x 30mm BS MDF Board in HPL Finish, w/ 2 pcs. Plastic Grannell w/ Rotating Cover					
2.	8 pc. Rectangular Worktop, 1200mm L x 600mm W x 30mm BS MDF Board in HPL Finish, w/ 2 pcs. Plastic Grannell w/ Rotating Cover					
c.	Accessories					
1.	8 units Center Drawer, 600mm W x 400mm D x 100mm H					
2.	8 units Detached Tray, Head Panel					
	4. Staff Workstation (SW-1)					
a.	Module Panels & Supports					
1.	14 pc. Polaris Screen Panel, Two-tone, 1000mm W x 700mm H x 40mm BS with Powder Coated Aluminum Panel Backery for Cable & Outlets					
2.	28 pc. Polaris Screen panel, Two-tone, 600mm W x 900mm H x 40mm BS with Powder Coated Aluminum Panel Backery for Cable & Outlets					
3.	28 pc. Aluminum End Ties, 900mm H	14.0	pc.			
4.	28 pc. Aluminum End Ties, 1800mm H					
5.	28 pc. Corner Pad, 2-way, 900mm H					
b.	Module Worktop					
1.	14 pc. Rectangular Worktop, 1200mm L x 600mm W x 30mm BS MDF Board in HPL Finish, w/ 2 pcs. Plastic Grannell w/ Rotating Cover					
c.	Accessories					
1.	14 units Detached Tray, Head Panel					

ITEM	DESCRIPTION	QTY	UNIT	UNIT COST	VAT (13%)	TOTAL COST
(A)	(B)	(C)	(D)	(E)	(F)	(G)
	6. Staff Workstation (29-D)					
	a. Module Panels & Supports					
1.	8 pks. Polaris Screen Panel, Two-tone, 1300mm W x 1300mm H x 30mm Hk with Powder Coated Aluminium Panel Backway for Cables & Outlets					
2.	16 pks. Polaris Screen panel, Two-tone, 800mm W x 900mm H x 30mm Hk with Powder Coated Aluminium Panel Backway for Cables & Outlets					
3.	16 pks. Aluminium End Ties, 600mm H	1.0	unit			
4.	16 pks. Aluminium End Ties, 800mm H					
5.	16 pks. Corner Pad, 2-way, 1300mm H					
	b. Module Worktop					
1.	8 pks. Rectangular Worktop, 1000mm L x 600mm W x 30mm Hk. MDF Based in HPL, Finish w/ (Spec. Plastic) Coated w/ Bubbling Cover					
	c. Accessories					
1.	8 units. Detachable Tray, Hard Plastic					
	7. Staff Workstation (29-B, Screenless back to back)					
	a. Module Panels & Supports					
1.	2 pks. Polaris Screen Panel, Two-tone, 1300mm W x 1300mm H x 30mm Hk with Powder Coated Aluminium Panel Backway for Cables & Outlets					
2.	8 pks. Polaris Screen panel, Two-tone, 800mm W x 900mm H x 30mm Hk with Powder Coated Aluminium Panel Backway for Cables & Outlets					
3.	8 pks. Aluminium End Ties, 600mm H	1.0	unit			
4.	8 pks. Aluminium End Ties, 800mm H					
5.	2 pks. Corner Pad, 2-way, 1300mm H					
6.	2 pks. Corner Pad, 2-way, 1300mm H					
	b. Module Worktop					
1.	4 pks. Rectangular Worktop, 1000mm L x 600mm W x 30mm Hk. MDF Based in HPL, Finish w/ (Spec. Plastic) Coated w/ Bubbling Cover					
	c. Accessories					
1.	4 units. Detachable Tray, Hard Plastic					
	8. Staff Workstation (29-A Two seater back to back)					
	a. Module Panels & Supports					
1.	2 pks. Polaris Screen Panel, Two-tone, 1300mm W x 1300mm H x 30mm Hk with Powder Coated Aluminium Panel Backway for Cables & Outlets					
2.	4 pks. Polaris Screen panel, Two-tone, 800mm W x 900mm H x 30mm Hk with Powder Coated Aluminium Panel Backway for Cables & Outlets					
3.	4 pks. Aluminium End Ties, 600mm H	1.0	unit			
4.	4 pks. Aluminium End Ties, 800mm H					
5.	2 pks. Corner Pad, 2-way, 1300mm H					
	b. Module Worktop					
1.	2 pks. Rectangular Worktop, 1000mm L x 600mm W x 30mm Hk. MDF Based in HPL, Finish w/ (Spec. Plastic) Coated w/ Bubbling Cover					
	c. Accessories					
1.	4 units. CPU Holder					
2.	4 units. Acrylic Plastic Divider					
3.	4 units. Pullout Drawer for Scanner					
	9. Computer Workstation (For SMD)					
	a. Free-Standing Computer Table (FST), 1000mm L x 600mm D x 740mm H. MDF Based in HPL, Finish, Post-Treated Panel & Back Edges w/ Co. 18 Legs Support Powder-Coated Finish w/ Integrated Cable Management Channel w/ Plastic Coated w/ Bubbling Cover	1.0	unit			
	10. ID-Capture Workstation					
	a. Module Panels & Supports					
1.	16 pks. Polaris Screen Panel, Two-tone, 1000mm W x 1800mm H x 30mm Hk with Powder Coated Aluminium Panel Backway for Cables & Outlets	1.0	unit			
2.	4 pks. Corner Pad, 2-way, 1800mm H					
3.	4 pks. Aluminium End Ties, 1800mm H					
	11. Desks & Tables					
	a. Free-Standing Table (FT) - 800mm L x 600mm D x 740mm H. MDF Based in HPL, Finish w/ Plastic Coated w/ Bubbling Cover	1.0	unit			
	b. Set of 4 - Module Meeting tables (600mm W x 1800mm L) supported by 40mm powder-coated chrome metal legs and bases	1.0	unit			
	c. Round Conference Table 600mm dia. MDF Based in HPL, Finish	1.0	unit			
	SUB-TOTAL - LDF I - REGULAR OFFICE SYSTEMS					
	II. Meeting Furniture					
1.	01 - Executive Chair, 2-piece, High Back	1.00	unit			
2.	02 - Supervisor's Chair, 1-piece, Mid Back w/ Armrest	10.00	unit			
3.	03 - Receptionist's Chair/Staff Chair, 1-piece, Low Back w/ Armrest	65.00	unit			
4.	04 - Visitor's High Chair w/ Footring, 2-piece, Mid Back	1.00	unit			
5.	05 - Board Chair 1, 2-piece, Mid Back, Cantilever Type (for Banquette) w/ Armrest	220.00	unit			
6.	06 - Board Chair 2, 2-piece, Mid Back w/ Armrest, w/ Padded Cushion	39.00	unit			
7.	07 - 8-Seater Dining Chair, 180mm x 60mm 60mm, Powder Coated Steel	1.0	unit			
8.	08 - 4-Seater Dining Chair, 180mm x 60mm 60mm, Powder Coated Steel	10.0	unit			
	SUB-TOTAL - LDF II - MEETING FURNITURE					

ITEM	DESCRIPTION	QTY	UNIT	UNIT COST	VAT (13%)	TOTAL COST
(A)	(B)	(C)	(D)	(E)	(F)	(G)
III CONTACT CENTER						
1. Reception Counter / General Counter (GRC)						
a. Module Panels & Supports						
1.	12	pcs.	Side Support Panel, 600mm W x 1000mm H x 20mm Th, MDF based in HPL Finish			
2.	4	pcs.	Front Module Panel, 1400mm W x 700mm H x 20mm Th, Marine Plywood w/ Horizontal Strips using 1/2" Th. MDF based in HPL Finish			
3.	4	pcs.	Side Module Panel, 1000mm W x 700mm H x 20mm Th, MDF based in HPL Finish			
4.	12	pcs.	Side Support Panel, 600mm W x 700mm H x 20mm Th, MDF based in PVC Film Finish			
b. Module Worktop						
1.	4	pcs.	Rectangular Worktop, 1400mm L x 700mm W x 20mm Th, w/ Synthetic Stone (Acrylic) w/ Plastic Channel w/ Rabbet Cover	4.0	units	-
2.	4	pcs.	Rectangular Worktop, 1000mm L x 400mm W x 20mm Th, w/ Synthetic Stone (Acrylic) w/ Plastic Channel w/ Rabbet Cover			
3.	4	pcs.	Undercounter ledge, 800mm L x 200mm W x 20mm Th, Particle Board in HPL Finish w/ Plastic Channel w/ Rabbet Cover			
c. Accessories						
1.	4	units	4 Layer Bullbit Covers, 400mm W x 400mm D x 20mm Th, MDF based in HPL Finish			
2.	4	units	100mm W x 100mm H 3D Logo in Stainless Steel Sheet			
3.	4	units	Replacement Tray, Hard Plastic			
2. Information Booth (IB)						
Dropped, 1800mm L x 1000mm W x 1100mm H x 18mm Th, Marine Plywood Corcase w/ Bullbit Covers						
1.0				1.0	unit	-
3. News Writing Counter (NWC)						
400mm W x 1800mm L x 1000mm H, Rectangular Shaped Writing Counter made of MDF based substrate in HPL Finish and 40mm powder-coated tubular desk leg						
1.0				1.0	units	-
4. Guard's Post						
Dropped, Guard Station in Marine Plywood Corcase, HPL Finish w/ Bullbit Covers, Stainless Steel Siding & Branded Logo						
1.0				1.0	unit	-
5. Manager's Desk Cabinet (MDC)						
1800mm W x 600mm D x 700mm H 18mm Th, Marine Plywood in PVC Film Finish or Approved Equal						
1.0				1.0	unit	-
SUB-TOTAL (LOT III) - CONTACT CENTER						
IV ITES, DESKTOP, CABINETS & DRAWERS						
1. Open Steel Drawers (OSD) - 40mm, 40x30						
				24.0	units	-
2. Lateral Filing Cabinet - 40mm						
				10.0	units	-
3. Mobile Pivoted Drawers 30mm, 400mm W x 600mm D x 600mm H						
				39.0	units	-
SUB-TOTAL (LOT IV) - ITES, DESKTOP, CABINETS & DRAWERS						
V PRINCE CHAIRS including labor and other expenses						
GRAND TOTAL						

GENERAL CONDITIONS

- For uniformity and evaluation purposes, a bidder shall adhere to the herein prescribed format of BOD, specifically to the formula for computation, given quantity and exclusive pay items. Any deviation from the format shall be a ground for disqualification of bid.
 - If set up of required items/field in the BOD, failure to indicate any of the following shall mean outright disqualification since bid is considered non-responsive:
 - * If item is given for free, indicate dash (-), zero (0) or free.
 - * If the item is not applicable, indicate N/A.
- Each bidder shall be provided with hard copy of the BOD Form (attached in the FBO) and an electronic copy for faster and easier encoding. The hard copy shall serve as the bidder's reference as to completeness of each item, quantity, formula, format, etc. in the BOD Form considering that the electronic copy is prone to alterations during encoding. Any discrepancy on the contents (quantity and the quantity and exclusive pay items) between the hard copy and electronic, the contents of the hard copy shall prevail.
- Bidder are not allowed to include any pay items that were not included in the form supplied by the Committee. In instances where necessary work items are inadvertently left out in BOD Form, a bidder should make a written query to the Bids and Awards Committee so that the same shall be addressed in the Bid Sublet which will be issued to all participating bidders.
- All documents must be signed, and each and every page thereof must be initialed by the duly authorized representative/s of the Bidder.
 - Unit Price of the Purchase Item shall include the following:
 - Material, fabrication and installation costs
 - Overhead expenses such as office expenses, supervision, transportation allowances, and financing costs (Premium on Cash, Bid Security, Performance Security, Surety for advance payment, Warranty bond)
 - Contingencies, miscellaneous expenses and Contractor's profit margin
- It is the responsibility of the Bidder to check the official/computer provided items.

Submitted by: _____
 (Name of Bidder / Company Name)

Required by: _____
 (Company Representative - Signature over printed name)

Address: _____

Telephone #: _____

Date: _____



Republic of the Philippines
SOCIAL SECURITY SYSTEM
 East Ave., Dilliman, Quezon City
 Tel. Nos. (632) 920-6401 * (632) 920-6464

Project : **SUPPLY, DELIVERY AND INSTALLATION OF MODULAR OFFICE SYSTEMS AND FURNITURE FOR VARIOUS SSS BRANCHES OFFICES**
Lot II - Luzon Branches

PRICE SCHEDULE(S)/ BID BREAKDOWN

	SSS BRANCH NAME	SUB-LIMIT	QTY	UNIT	TOTAL AMOUNT
1	SSS VIGAN	3,017,755.08	1	LOT	
2	SSS BALER	1,348,308.00	1	LOT	
3	SSS SAN PEDRO	2,508,790.00	1	LOT	
4	SSS TUGUEGARAO	4,625,000.00	1	LOT	
5	SSS TABACO	2,795,091.08	1	LOT	
GRAND TOTAL					

Amount in Words	
------------------------	--

Note:

- 1 Any bid exceeding the sub-limit per branch shall not be accepted.
- 2 Bids must be inclusive of freight cost and all applicable charges and taxes.
- 3 Fill up all required items/field in the bid breakdown. Failure to indicate any of the following shall mean outright disqualification since bid is considered Non-Responsive.
 - If the item is given for free, indicate dash (-), zero (0) or free
 - If the item is not applicable, indicate N/A
- 4 All documents shall be signed, and each and every page thereof shall be initialed, by the duly authorized representative/s of the Bidder.
- 5 Warranty requirement is at no cost to SSS.

Name: _____

Legal capacity: _____

Signature: _____

Duly authorized to sign the Bid for and behalf of: _____



Republic of the Philippines
SOCIAL SECURITY SYSTEM
 West Ave., Ortigas, Quezon City

Project: **SUPPLY, DELIVERY AND INSTALLATION OF MODULAR OFFICE SYSTEM AND FURNITURE FOR VARIOUS SSS BRANCH OFFICES**
 Location: **355 Nigan, 2F UNP Town Center, Brgy. Tamag, Nigan City, Ilocos Sur**

BILL OF QUANTITIES								
ITEM	DESCRIPTION			QTY	UNIT	UNIT COST	VAT (12%)	TOTAL COST
[A.]	[B.]			[C.]	[D.]	[E.]	[F.]	[G.]
MODULAR OFFICE SYSTEM								
1. Branch Head Workstation (BHW)								
	14.	1	pc.	Integrated Free-Standing Executive Table, 1800mm L x 1100mm D x 1100mm H in 30mm FR MDF Board (Antistatic w/ Plastic Coating) w/ Bolted Corner and 120mm FR MDF Board Side Support in RPJ Panel				
	15.	1	pc.	1.0	wt			
	Side Belter Table (300mm L x 400mm D x 700mm H) 30mm FR MDF Board (Antistatic w/ Plastic Coating) w/ Bolted Corner, Cast-Aluminum Base in Powder Coated Reg. Legs Support and Cast-Aluminum Movable Panel in Powder Coated Mesh							
	c. Accessories							
	1.	1	pc.	Center Drawer, 600mm W x 400mm D x 100mm H				
	2.	1	pc.	Keyboard Tray, 600mm W x 400mm D x 100mm H				
1. Branch Head Workstation (BHW-1)								
	14. Modular Panels & Supports							
	1.	4	pc.	Antistatic Screen Panel, Two-tone, 1000mm W x 1000mm H x 30mm FR with Powder Coated Aluminum Panel Backing for Cables & Coils				
	2.	4	pc.	Antistatic Screen Panel, Two-tone, 600mm W x 1000mm H x 30mm FR with Powder Coated Aluminum Panel Backing for Cables & Coils				
	3.	4	pc.	Antistatic Screen Panel, Two-tone, 600mm W x 1000mm H x 30mm FR with Powder Coated Aluminum Panel Backing for Cables & Coils				
	4.	4	pc.	Antistatic Screen Panel, Horizontal, 1000mm W x 700mm H x 30mm FR with Powder Coated Aluminum Panel Backing for Cables & Coils				
	5.	4	pc.	Antistatic Screen Panel, Two-tone, 1200mm W x 600mm H x 30mm FR with Powder Coated Aluminum Panel Backing for Cables & Coils				
	6.	4	pc.	Aluminum End Bar, 1000mm H				
	7.	4	pc.	Aluminum End Bar, 600mm H				
	8.	4	pc.	Aluminum End Bar, 600mm H				
	9.	4	pc.	Aluminum End Bar, 1000mm H				
	10.	12	pc.	Corner Post, 2-way, 1000mm H				
	11.	4	pc.	Corner Post, 2-way, 600mm H				
	15. Modular Worktop							
	1.	4	pc.	Backtopped Worktop, 1000mm L x 600mm W x 30mm FR MDF Board in RPJ Panel w/ Spun-Plastic Coating w/ Bolted Corner				
	2.	4	pc.	Backtopped Worktop, 1000mm L x 600mm W x 30mm FR MDF Board in RPJ Panel w/ Spun-Plastic Coating w/ Bolted Corner				
	c. Accessories							
	1.	4	wt.	Center Drawer, 600mm W x 400mm D x 100mm H				
	2.	4	wt.	Keyboard Tray, 600mm W x 400mm D x 100mm H				
1. Staff Workstation (SW-1)								
	14. Modular Panels & Supports							
	1.	3	pc.	Antistatic Screen Panel, Horizontal, 1000mm W x 700mm H x 30mm FR with Powder Coated Aluminum Panel Backing for Cables & Coils				
	2.	10	pc.	Antistatic Screen Panel, Two-tone, 1200mm W x 600mm H x 30mm FR with Powder Coated Aluminum Panel Backing for Cables & Coils				
	3.	10	pc.	Aluminum End Bar, 600mm H				
	4.	10	pc.	Aluminum End Bar, 1000mm H				
	5.	10	pc.	Corner Post, 2-way, 600mm H				
	15. Modular Worktop							
	1.	3	pc.	Backtopped Worktop, 1000mm L x 600mm W x 30mm FR MDF Board in RPJ Panel w/ Spun-Plastic Coating w/ Bolted Corner				
	c. Accessories							
	1.	3	wt.	Keyboard Tray, 600mm W x 400mm D x 100mm H				
1. Staff Workstation (SW-2, Two-seater desk in back)								
	14. Modular Panels & Supports							
	1	2	pc.	Antistatic Screen Panel, Two-tone, 1000mm W x 1000mm H x 30mm FR with Powder Coated Aluminum Panel Backing for Cables & Coils				
	2	4	pc.	Antistatic Screen Panel, Two-tone, 1200mm W x 600mm H x 30mm FR with Powder Coated Aluminum Panel Backing for Cables & Coils				
	3	4	pc.	Aluminum End Bar, 600mm H				
	4	4	pc.	Aluminum End Bar, 1000mm H				
	5	2	pc.	Corner Post, 2-way, 1000mm H				
	6	1	pc.	Corner Post, 2-way, 1000mm H				
	15. Modular Worktop							
	1	4	pc.	Backtopped Worktop, 1000mm L x 600mm W x 30mm FR MDF Board in RPJ Panel w/ Spun-Plastic Coating w/ Bolted Corner				
	c. Accessories							
	1	4	wt.	Keyboard Tray, 600mm W x 400mm D x 100mm H				
1. Computer Workstation (for BMS)								
	14.			Free-Standing Computer Table (FC), 1000mm L x 600mm D x 700mm H x 30mm FR MDF Board in RPJ Panel, Front-Inward Panel & Back Edges w/ Cast-Aluminum Support Powder Coated Mesh w/ Integrated Cable Management Channel w/ Plastic Coating w/ Bolted Corner				
				4.0	wt.			
1. ID Capture Workstation								
	14. Modular Panels & Supports							
	1.	14	pc.	Antistatic Screen Panel, Two-tone, 1000mm W x 1000mm H x 30mm FR with Powder Coated Aluminum Panel Backing for Cables & Coils				
	2.	4	pc.	Corner Post, 2-way, 1000mm H				
	3.	4	pc.	Aluminum End Bar, 1000mm H				
	15. Modular Worktop							
	1.	3	pc.	Backtopped Worktop, 1000mm L x 600mm W x 30mm FR MDF Board in RPJ Panel w/ Spun-Plastic Coating w/ Bolted Corner				
	c. Accessories							
	1.	3	wt.	CPU Holder				
	2.	3	wt.	Airjet Plastic Shaker				
	3.	3	wt.	Roller Drawer for Scanner				

BID#	DESCRIPTION	QTY	UNIT	UNIT COST	VAT (13%)	TOTAL COST	
(A)	(B)	(C)	(D)	(E)	(F)	(G)	
A. Desks & Tables							
	1. Round/Rectangular Table (RT) - 800mm L x 600mm D x 750mm H MDF based in RP, Finish of Plastic Commercial Building Coats	2.0	units		-	-	
	2. Set of 2 - Modular Seating Tables (ST) 600mm W x 500mm L supported by 40mm powder coated tubular metal legs and bases	1.0	set		-	-	
	3. Round Conference Table, 900mm dia, MDF based in RP Finish	1.0	unit		-	-	
		SUB TOTAL - LOT 1 - MODULAR OFFICE FURNITURE					-
B. OFFICE EQUIPMENT							
	1.01 - Executive Chair, System, High Back	1.00	unit		-	-	
	1.02 - Supervisor's Chair, System, Mid Back w/ Armrest	3.00	units		-	-	
	1.03 - Staff/Supervisor's Chair/Office Chair, System, Low Back w/ Armrest	20.00	units		-	-	
	1.04 - Visitor's High Chair w/ Footrest, System, Mid Back	3.00	units		-	-	
	1.05 - Guest Chair 1, System, Mid Back, Comforter Type (for Reception w/ Armrest)	1.00	unit		-	-	
	1.06 - Guest Chair 2, System, Seat base w/ Armrest, w/ Foam Cushion	24.00	units		-	-	
	1.07 - 4 Seater Group Chair (200mm dia, 400mm dia, 400mm dia, 400mm dia)	11.00	units		-	-	
		SUB TOTAL - LOT 1 - OFFICE EQUIPMENT					-
C. CONTRACT FURNITURE							
1. Reception Counter / Reception Counter (RC)							
a. Modular Panels & Supports							
	1. B	pcs.	Side Support Panel, 600mm W x 1200mm H x 20mm TH, MDF based in RP Finish				
	2. A	PCS	Front Mainbody Panel, 1800mm W x 750mm H x 20mm TH, Modular Plywood w/ Melamine/Decorating LSP/PA MDF based in RP Finish				
	3. A	pcs.	Side Mainbody Panel, 1000mm W x 750mm H x 20mm TH, MDF based in RP Finish				
	4. B	pcs.	Side Support Panel, 400mm W x 700mm H x 20mm TH, MDF based in PVC Res Finish				
b. Modular Worktop							
	1. A	PCS	Rectangular Worktop, 1800mm L x 750mm W x 20mm TH, w/ Synthetic Stone (Quartz) w/ Plastic Commercial w/ Building Coats	4.0		-	
	2. A	PCS	Rectangular Worktop, 1000mm L x 400mm W x 20mm TH, w/ Synthetic Stone (Quartz) w/ Plastic Commercial w/ Building Coats				
	3. A	pcs.	Undercounter Edge, 800mm L x 200mm W x 20mm TH, Particle Board in RP Finish w/ Plastic Commercial Building Coats				
c. Accessories							
	1. A	units	4 Layer Ball in Cones, 400mm W x 400mm D x 20mm TH, MDF based in RP Finish				
	2. A	units	100mm W x 100mm H/30 Legs in Melamine Steel Sheet				
	3. A	units	Expanded Top, Steel Finish				
	1. Information Booth (Info)		Drop-top, 1800mm L x 1000mm W x 1000mm H x 20mm TH Modular Plywood Counter w/ Ball in Cones	1.0		-	
	1. News Writing Counter (NWC)		400mm W x 1800mm L x 1000mm H Rectangular Shaped Writing Counter made of MDF based finishing in RP Finish and 40mm powder coated tubular standing leg	1.0		-	
	1. Quartz's Post		Drop-top Counter Station in Modular Plywood Counter, RP, Finish w/ Ball in Cones, Exhibits Steel Sheet Dining & Restaurant Legs	1.0		-	
	1. Manager's Desk Cabinet (MDC)		1800mm W x 600mm D x 750 mm H 1 Row TH Modular Plywood in PVC Res Finish w/ Approved Sign	1.0		-	
		SUB TOTAL - LOT 1 - CONTRACT FURNITURE					-
D. TRAVEL EXPENSE, CATERING & DISHWASH							
	1. Open Road Expenses (ORE) 4 days, One/18	20.0	units		-	-	
	2. Catering & Dishwash, 4 Days	3.0	units		-	-	
	3. Mobile Permitted Expenses, 5-Days, 400mm W x 1600mm D x 400mm H	24.0	units		-	-	
		SUB TOTAL - LOT 1 - TRAVEL EXPENSE, CATERING & DISHWASH					-
E. BIDDING CHARGE (including Labor and Other Expenses)							
						GRAND TOTAL	

GENERAL CONDITIONS

- For utility and evaluation purposes, a bidder shall adhere to the terms (provided) format of BOC, specifically in the format for a computer, given quantity and exclusive pay item. Any deviation from the format shall be a ground for disqualification of bid.
 - BE up all required items listed in the BOC, failure to indicate any of the following shall mean outright disqualification since bid is considered non-comparable.
 - * Items to give for free, indicate dash (-), zero (0) or free
 - * If item is not applicable, indicate N/A
- Each bidder shall be provided with hard copy of the BOC form (attached in the PSD) and an electronic copy for bid and tender encoding. The hard copy shall serve as the bidder's reference as to completeness of each item, quantity, format, format, etc. in the BOC form considering that the electronic copy is prone to alterations during encoding. Any discrepancy on the contents (especially on the quantity and exclusive pay item) between the hard copy and electronic, the contents of the hard copy shall prevail.
- Bidder are not allowed to include any pay item that were not included in the form supplied BE of Quantities, in instances where necessary work items are inadvertently left out in BOC form, a bidder should make a written query to the National Awards Committee so that the same shall be addressed in the BE of Quantities which will be issued to all participating bidders.
- All documents must be signed, and each and every page thereof must be initialed by the duly authorized representative(s) of the bidder.
 - Unit Price of the Pay Item shall include the following:
 - Materials, fabrication and installation costs
 - Operational expenses such as office expenses, supervision, transportation allowances, and bonding costs (Premium on CMI, Bid Security, Performance Security, Surety for advance payment, Warranty bond)
 - Contingencies, Miscellaneous Expenses and Contractor's Profit margin
- It is the responsibility of the Bidder to check the sufficiency of computer provided items.

Submitted by: _____
(Name of Bidder / Company Name)

Prepared by: _____
(Company Representative - Signature over printed name)

Address: _____

Telephone #: _____

Date: _____



Project: **FREE**
 Location: **SSS Bldg, S/T NE Pacific Mall Bldg, Bgy. Subayan, Baler, Aurora**

BILL OF QUANTITIES

ITEM	DESCRIPTION	QTY	UNIT	UNIT COST	VAT (12%)	TOTAL COST
(A)	(B)	(C)	(D)	(E)	(F)	(G)
1	MODULAR OFFICE SYSTEMS					
	1. Branch Head Workstation (BWH)					
a.	1 pc. Driveway Free-Standing Executive Table, 1800mm L x 750mm D x 750mm H w/ 30mm Blk MDF Board Topping w/ Plastic Coarment w/ Rotating Cover and 30mm Blk MDF Board Side Support in RFL Finish					
b.	1 pc. Side Return Table 1200mm L x 600mm D x 750mm H x 30mm Blk MDF Board Coarment w/ Plastic Coarment w/ Rotating Cover, Co. 18 Metal Steel in Powder Coated Finish Legs Support and Co.20 Steel Meshy Panel in Powder Coated Finish	1.0	unit		-	-
c.	Accessories					
1.	1 pc. Center Drawer, 600mm W x 400mm D x 100mm H					
2.	1 pc. Detached Tray, Head Panel					
	2. Section Head Workstation (SHW-1)					
a.	Module Panels & Supports					
1.	3 pcs. Polaris Screen Panel, Two-tone, 1200mm W x 1200mm H x 30mm Blk with Powder Coated Aluminum Panel Backery for Cable & Outlets					
2.	3 pcs. Polaris Screen Panel, Two-tone, 600mm W x 1200mm H x 30mm Blk with Powder Coated Aluminum Panel Backery for Cable & Outlets					
3.	3 pcs. Polaris Screen Panel, Two-tone, 600mm W x 1200mm H x 30mm Blk with Powder Coated Aluminum Panel Backery for Cable & Outlets					
4.	3 pcs. Polaris Screen Panel, Monochrome, 1000mm W x 700mm H x 30mm Blk with Powder Coated Aluminum Panel Backery for Cable & Outlets					
5.	3 pcs. Polaris Screen Panel, Two-tone, 600mm W x 900mm H x 30mm Blk with Powder Coated Aluminum Panel Backery for Cable & Outlets					
6.	3 pcs. Aluminum End Ties, 1200mm H	3.0	unit		-	-
7.	3 pcs. Aluminum End Ties, 900mm H					
8.	3 pcs. Aluminum End Ties, 600mm H					
9.	3 pcs. Aluminum End Ties, 300mm H					
10.	4 pcs. Corner Pad, 3-way, 1200mm H					
11.	3 pcs. Corner Pad, 3-way, 900mm H					
b.	Module Worktop					
1.	3 pcs. Rectangular Worktop, 1200mm L x 600mm W x 30mm Blk MDF Board in RFL Finish, w/ 2yrs. Plastic Coarment w/ Rotating Cover					
2.	3 pcs. Rectangular Worktop, 1200mm L x 600mm W x 30mm Blk MDF Board in RFL Finish, w/ 2yrs. Plastic Coarment w/ Rotating Cover					
c.	Accessories					
1.	3 units. Center Drawer, 600mm W x 400mm D x 100mm H					
2.	3 units. Detached Tray, Head Panel					
	3. Staff Workstation (SW-1)					
a.	Module Panels & Supports					
1.	4 pcs. Polaris Screen Panel, Monochrome, 1000mm W x 700mm H x 30mm Blk with Powder Coated Aluminum Panel Backery for Cable & Outlets					
2.	12 pcs. Polaris Screen Panel, Two-tone, 600mm W x 900mm H x 30mm Blk with Powder Coated Aluminum Panel Backery for Cable & Outlets					
3.	12 pcs. Aluminum End Ties, 900mm H	4.0	unit		-	-
4.	12 pcs. Aluminum End Ties, 300mm H					
5.	12 pcs. Corner Pad, 3-way, 900mm H					
b.	Module Worktop					
1.	4 pcs. Rectangular Worktop, 1200mm L x 600mm W x 30mm Blk MDF Board in RFL Finish, w/ 2yrs. Plastic Coarment w/ Rotating Cover					
c.	Accessories					
1.	4 units. Detached Tray, Head Panel					
	4. Computer Workstation (PC/SMC)					
a.	Free-Standing Computer Table (F12), 1000mm L x 600mm D x 750mm H x 30mm Blk MDF Board in RFL Finish, Post-Slotted Panel & Back Edges w/ Co. 18 Legs Support Powder-Coated Finish w/ Integrated Cable Management Channel w/ Plastic Coarment w/ Rotating Cover	1.0	unit		-	-
	5. ID Capture Workstation					
a.	Module Panels & Supports					
1.	2 pcs. Polaris Screen Panel, Two-tone, 1000mm W x 1200mm H x 30mm Blk with Powder Coated Aluminum Panel Backery for Cable & Outlets	1.0	unit		-	-
2.	3 pcs. Corner Pad, 3-way, 1200mm H					
3.	2 pcs. Aluminum End Ties, 1200mm H					
	6. Desks & Tables					
a.	Executive Conference Table (3-seater, Back Slope w/ Wire Management) MDF Board in RFL Finish	1.0	unit		-	-
	SUB-TOTAL - LCP I - MODULAR OFFICE SYSTEMS					
2	BATHING FURNITURE					
1.	21 - Executive Chair, 2-piece, High Back	1.00	unit		-	-
2.	22 - Supervisor's Chair, 1-piece, Mid Back w/ Armrest	2.00	unit		-	-
3.	23 - Non-Supervisor's Chair/Staff Chair, 1-piece, Low Back w/ Armrest	14.00	unit		-	-
4.	24 - Teller's High Chair w/ Rotating, 2-piece, Mid Back	1.00	unit		-	-
5.	25 - Board Chair 1, 2-piece, Mid Back, Cantilever Type (For Executive) w/ Armrest	2.00	unit		-	-
6.	26 - Board Chair 2, 2-piece, Mid Back w/ Armrest w/ Padded Cushion	11.00	unit		-	-
7.	27 - 3-Seater Gang Chair, 180mm x 60mm x 60mm, Powder Coated Steel	3.0	unit		-	-
8.	28 - 4-Seater Gang Chair, 210mm x 60mm x 60mm, Powder Coated Steel	3.0	unit		-	-
	SUB-TOTAL - LCP II - BATHING FURNITURE					

ITEM	DESCRIPTION	QTY	UNIT	UNIT COST	VAT (13%)	TOTAL COST
(A)	(B)	(C)	(D)	(E)	(F)	(G)
III CONTACT CENTER						
1. Reception Counter / Generalist Counter (GNC)						
a. Module Panels & Supports						
1.	4	PNL	Side Support Panel, 800mm W x 1000mm H x 20mm TH, MDF Based in HPL Finish			
2.	2	PNL	Front Module Panel, 1400mm W x 700mm H x 20mm TH, Marine Plywood w/ Horizontal Strips using 1/2" TH MDF Based in HPL Finish			
3.	2	PNL	Side Module Panel, 1000mm W x 700mm H x 20mm TH, MDF Based in HPL Finish			
4.	4	PNL	Side Support Panel, 400mm W x 700mm H x 20mm TH, MDF Based in PVC Film Finish			
b. Module Worktop						
1.	2	PNL	Rectangular Worktop, 1400mm L x 700mm W x 20mm TH, w/ Synthetic Stone (Acrylic) w/ Plastic Channel w/ Rounding Curve	20	units	-
2.	2	PNL	Rectangular Worktop, 1000mm L x 400mm W x 20mm TH, w/ Synthetic Stone (Acrylic) w/ Plastic Channel w/ Rounding Curve			
3.	2	PNL	Undercounter Ledge, 800mm L x 200mm W x 20mm TH, Particle Board in HPL Finish w/ Plastic Channel w/ Rounding Curve			
c. Accessories						
1.	2	units	4-Layer Bull-It Covers, 400mm W x 400mm D x 20mm TH, MDF Based in HPL Finish			
2.	2	units	100mm W x 100mm H 300 Logo in Stainless Steel Sheet			
3.	2	units	Replacable Tray, Hard Plastic			
2. Information Booth (IBO)						
Dropped, 1800mm L x 1000mm W x 1100mm H x 30mm TH, Marine Plywood Cabinet w/ Bull-It Drawers						
1.0		unit				-
3. News Writing Counter (NWC)						
400mm W x 1800mm L x 1000mm H, Rectangular Shaped Writing Counter made of MDF based substrate in HPL Finish and 40mm powder-coated tubular desk leg						
1.0		unit				-
4. Guard's Post						
Dropped Guard Station in Marine Plywood Cabinet, HPL Finish w/ Bull-It Drawers, Stainless Steel Siding & Branded Logo						
1.0		unit				-
5. Manager's Desk Cabinet (MDC)						
1800mm W x 400mm D x 700mm H 30mm TH, Marine Plywood in PVC Film Finish or Approved Equal						
1.0		unit				-
SUB-TOTAL - LOT III - CONTACT CENTER						
IV ITSS, SERVER, CABINET & DRAWER						
1. Open Steel Drawers (OSD), 4-Drawer, 60x60						
20		units				-
2. Lateral Plug Cabinet, 4-Drawers						
20		units				-
3. Mobile Perforated Drawers, 3-Drawers, 400mm W x 600mm D x 400mm H						
10		units				-
SUB-TOTAL - LOT IV - ITSS, SERVER, CABINET & DRAWER						
V FRONT CHAIRS including labor and other expenses						
GRAND TOTAL						

GENERAL CONDITIONS

- For uniformity and evaluation purposes, a bidder shall adhere to the herein prescribed format of BOD, specifically to the format for computation, given quantity and exclusive pay items. Any deviation from the format shall be a ground for disqualification of bid.
 - Setup of required items/field in the BOD. Failure to indicate any of the following shall mean outright disqualification since bid is considered non-responsive:
 - * If item is given for free, indicate dash (-), zero (0) or free
 - * If the item is not applicable, indicate N/A
- Each bidder shall be provided with hard copy of the BOD Form (attached in the FBD) and an electronic copy for later and easier encoding. The hard copy shall serve as the bidder's reference as to completeness of each item, quantity, formula, format, etc. in the BOD Form considering that the electronic copy is prone to alterations during encoding. Any discrepancy on the contents (quantity and the quantity and exclusive pay items) between the hard copy and electronic, the contents of the hard copy shall prevail.
- Bidder are not allowed to include any pay items that were not included in the form supplied BOD of Quantities. In instances where necessary work items are inadvertently left out in BOD Form, a bidder should make a written query to the Bids and Awards Committee so that the same shall be addressed in the Bid Bulletin which will be issued to all participating bidders.
- All documents must be signed, and each and every page thereof must be initialed by the duly authorized representative(s) of the Bidder.
 - Unit Price of the Purchase Item shall include the following:
 - Materials, fabrication and installation costs
 - Overhead expenses such as office expenses, expenditure, transportation allowances, and bonding costs (Premium on CMT, Bid Security, Performance Security, Surety for advance payment, Warranty bond)
 - Contingencies, miscellaneous expenses and Contractor's profit margin
- It is the responsibility of the Bidder to check the official computer provided items.

Submitted by: _____
 (Name of Bidder / Company Name)

Prepared by: _____
 (Company Representative - Signature over printed name)

Address: _____

Telephone #: _____

Date: _____



Republic of the Philippines
SOCIAL SECURITY SYSTEM
 East Ave., Diliman, Quezon City

Project: **FRF1**
 Location: 2nd Floor Robinson's Galleria South, San Pedro, Laguna

BILL OF QUANTITIES							
ITEM	DESCRIPTION			QTY	UNIT	UNIT COST	TOTAL COST
(A)	(B)			(C)	(D)	(E)	(F)
1	MODULAR OFFICE SYSTEM						
	1. Branch Head Workstation (BHW)						
a.	1	pc.	2-angled Free-Standing Executive Table, 1800mm L x 750mm D x 750mm H in 30mm Hx MDF Board/Tabling w/ Plastic Coarmental w/ Rotating Cover and 30mm Hx MDF Board Side Support in HPL Finish				
b.	1	pc.	Side Return Table 1200mm L x 400mm D x 750mm H x 30mm Hx MDF Board CAM/Tabling w/ Plastic Coarmental w/ Rotating Cover, Co.18 Metal Steel in Powder Coated With Legs Support and Co.22 Steel Meshy Panel in Powder Coated Mesh	1.0	unit		
c.	Accessories						
1.	1	pc.	Center Drawer, 600mm W x 400mm D x 100mm H				
2.	1	pc.	Desktop Tray, Head Panel				
	2. Section Head Workstation (SHW 1)						
a.	Module Panels & Supports						
1.	3	pc.	Polaris Screen Panel, Two-tone, 1200mm W x 1200mm H x 30mm Hx with Powder Coated Aluminum Panel Backery for Cable & Outlets				
2.	3	pc.	Polaris Screen Panel, Two-tone, 600mm W x 1200mm H x 30mm Hx with Powder Coated Aluminum Panel Backery for Cable & Outlets				
3.	3	pc.	Polaris Screen Panel, Two-tone, 600mm W x 1200mm H x 30mm Hx with Powder Coated Aluminum Panel Backery for Cable & Outlets				
4.	3	pc.	Polaris Screen Panel, Alternating, 1800mm W x 750mm H x 30mm Hx with Powder Coated Aluminum Panel Backery for Cable & Outlets				
5.	3	pc.	Polaris Screen Panel, Two-tone, 600mm W x 900mm H x 30mm Hx with Powder Coated Aluminum Panel Backery for Cable & Outlets				
6.	3	pc.	Aluminum End Ties, 1200mm H	30	units		
7.	3	pc.	Aluminum End Ties, 900mm H				
8.	3	pc.	Aluminum End Ties, 600mm H				
9.	3	pc.	Aluminum End Ties, 300mm H				
10.	10	pc.	Corner Pad, 2-way, 1200mm H				
11.	3	pc.	Corner Pad, 2-way, 900mm H				
b.	Module Worktop						
1.	3	pc.	Rectangular Worktop, 1200mm L x 600mm W x 30mm Hx MDF Board in HPL Finish, w/ 2 pcs. Plastic Coarmental w/ Rotating Cover				
2.	3	pc.	Rectangular Worktop, 1200mm L x 600mm W x 30mm Hx MDF Board in HPL Finish, w/ 2 pcs. Plastic Coarmental w/ Rotating Cover				
c.	Accessories						
1.	3	units	Center Drawer, 600mm W x 400mm D x 100mm H				
2.	3	units	Desktop Tray, Head Panel				
	3. Staff Workstation (SW 1)						
a.	Module Panels & Supports						
1.	12	pc.	Polaris Screen Panel, Alternating, 1200mm W x 750mm H x 30mm Hx with Powder Coated Aluminum Panel Backery for Cable & Outlets				
2.	24	pc.	Polaris Screen panel, Two-tone, 600mm W x 900mm H x 30mm Hx with Powder Coated Aluminum Panel Backery for Cable & Outlets	12.0	units		
3.	24	pc.	Aluminum End Ties, 900mm H				
4.	24	pc.	Aluminum End Ties, 600mm H				
5.	24	pc.	Corner Pad, 2-way, 900mm H				
b.	Module Worktop						
1.	12	pc.	Rectangular Worktop, 1200mm L x 600mm W x 30mm Hx MDF Board in HPL Finish, w/ 2 pcs. Plastic Coarmental w/ Rotating Cover				
c.	Accessories						
1.	12	units	Desktop Tray, Head Panel				
	4. Computer Workstation (PC/SMART)						
a.			Free-Standing Computer Table (FST), 1800mm L x 600mm D x 750mm H x 30mm Hx MDF Board in HPL Finish, Post-formed Panel & Back Edges w/ Co.18 Legs Support Powder-Coated Mesh w/ Integrated Cable Management Channel w/ Plastic Coarmental w/ Rotating Cover	1.0	unit		
	5. 1D Capture Workstation						
a.	Module Panels & Supports						
1.	7	pc.	Polaris Screen Panel, Two-tone, 1000mm W x 1800mm H x 30mm Hx with Powder Coated Aluminum Panel Backery for Cable & Outlets	1.0	unit		
2.	3	pc.	Corner Pad, 2-way, 1800mm H				
3.	7	pc.	Aluminum End Ties, 1800mm H				
	6. 8-Counter Station (750mm tabletop height)						
a.	Module Panels & Supports						
1.	30	pc.	Polaris Screen Panel, Two-tone, 600mm W x 1100mm H x 30mm Hx with Powder Coated Aluminum Panel Backery for Cable & Outlets				
2.	10	pc.	Polaris Screen Panel, Two-tone, 700mm W x 1100mm H x 30mm Hx with Powder Coated Aluminum Panel Backery for Cable & Outlets				
3.	30	pc.	Aluminum End Ties, 1100mm H	10.0	units		
4.	30	pc.	Corner Pad, 2-way, 1100mm H				
b.	Module Worktop						
1.	10	pc.	Rectangular Worktop, 700mm L x 600mm W x 30mm Hx MDF Board in HPL Finish, w/ 1 pc. Plastic Coarmental w/ Rotating Cover				
c.	Accessories						
1.	10	units	CPU Holder				
2.	10	units	Acrylic Plastic Divider				
3.	10	units	Full-out Drawer for Scanner				
	7. Desks & Tables						
a.			Free-Standing Printer Table (PT) - 800mm L x 400mm D x 740mm H MDF Board in HPL Finish w/ Plastic Coarmental w/ Rotating Cover	2.0	units		
b.			Round Conference Table, 700mm dia. MDF Board in HPL Finish	1.0	unit		
SUB-TOTAL - LCP 1 - MODULAR OFFICE SYSTEM							

ITEM	DESCRIPTION	QTY	UNIT	UNIT COST	VRU (12%)	NET COST
(A)	(B)	(C)	(D)	(E)	(F)	(G)
II - METAL FURNITURE						
1. 21	Executive Chair, Ergonomic High Back	1.00	unit	-	-	-
2. 22	Supervisor's Chair, Ergonomic, Mid Back w/ Armrest	8.00	units	-	-	-
3. 23	Non-Supervisor's Chair/Staff Chair, Ergonomic, Low Back w/ Armrest	27.00	units	-	-	-
4. 24	Teller's High Chair w/ Footing, 2 pieces, Mid Back	1.00	unit	-	-	-
5. 25	Stool Chair 1, Ergonomic, Mid Back, Casters/5 Legs (for Executive) w/ Armrest	2.00	units	-	-	-
6. 26	Stool Chair 2, Ergonomic, Mid Back w/ Armrest w/ Backrest	20.00	units	-	-	-
7. 28	4 Seater Gang Chair, 200mm x 60mm 18mm, Powder Coated Steel	12.00	units	-	-	-
SUB-TOTAL - LOT II - METAL FURNITURE						
III - CONTRACT FURNITURE						
1.	Transaction Counter / Generalist Counter (PVC)					
a. Module Panels & Supports						
1.	8	PVA	Side Support Panel, 600mm W x 1200mm H x 20mm TH, MDF Board in HPL Finish			
2.	4	PVA	Panel Assembly Panel, 1400mm W x 700mm H x 20mm TH, Marine Plywood w/ Horizontal Strips using 1/2" TH MDF Board in HPL Finish			
3.	4	PVA	Side Assembly Panel, 1000mm W x 700mm H x 20mm TH, MDF Board in HPL Finish			
4.	8	PVA	Side Support Panel, 600mm W x 700mm H x 20mm TH, MDF Board in PVC Film Finish			
b. Module Worktop						
1.	4	PVA	Rectangular Worktop, 1400mm L x 700mm W x 20mm TH, w/ Synthetic Stone (Acrylic) w/ Panels Grained w/ Rounding Corner	40	unit	-
2.	4	PVA	Rectangular Worktop, 1000mm L x 600mm W x 20mm TH, w/ Synthetic Stone (Acrylic) w/ Panels Grained w/ Rounding Corner			
3.	4	PVA	Undercounter Ledge, 800mm L x 200mm W x 20mm TH, Particle Board in HPL Finish w/ Panels Grained w/ Rounding Corner			
c. Accessories						
1.	4	units	4 Edge Bullbit Covers, 600mm W x 600mm D x 20mm TH, MDF Board in HPL Finish			
2.	4	units	100mm W x 100mm H 100 Logo in Stainless Steel Sheet			
3.	4	units	Desktop Tray, Metal Panels			
2.	Information Booth (Info)					
Dropped, 1800mm L x 1000mm W x 1100mm H x 18mm TH, Marine Plywood Corcase w/ Bullbit Covers						
1.0	unit					
3.	Non-Writing Counter (PVC)					
600mm W x 1800mm L x 1000mm H Rectangular Slanted Writing Counter made of MDF board finishing in HPL, 18mm and epoxyresin-coated fabric cladding top						
20	units					
4.	Guard's Post					
Dropped Guard Station in Marine Plywood Corcase, HPL Finish w/ Bullbit Covers, Stainless Steel Slanted L & Branded Logo						
1.0	unit					
5.	Manager's Desk Cabinet (PVC)					
1800mm W x 600mm D x 750 mm H 18mm TH, Marine Plywood in PVC Film Finish or Approved Equal						
1.0	unit					
SUB-TOTAL - LOT III - CONTRACT FURNITURE						
IV - STEEL SHELVES, CABINETS & DRAWERS						
1.	Open Steel Shelves (OSS), 4 Layer, 60 x 18	4.0	units			
2.	Lateral Filing Cabinet, 4-Drawers	4.0	units			
3.	Mobile Padded Drawers 3-Drawers, 600mm W x 600mm D x 600mm H	18.0	units			
SUB-TOTAL - LOT IV - STEEL SHELVES, CABINETS & DRAWERS						
V - BIDDING CHARGES including Labor and Other Expenses						
GRAND TOTAL						

GENERAL CONDITIONS

- For uniformity and evaluation purposes, a bidder shall adhere to the herein prescribed format of BOC, specifically to the format for completion, given quantity and inclusive pay items. Any deviation from the format shall be a ground for disqualification of bid.
 - Fill up of required items listed in the BOC. Failure to indicate any of the following shall mean outright disqualification since bid is considered non-responsive:
 - * If item is given for free, indicate dash (-), zero (0) or free
 - * If the item is not applicable, indicate N/A
- Each bidder shall be provided with hard copy of the BOC Form (attached in the PBD) and an electronic copy for faster and easier encoding. The hard copy shall serve as the bidder's reference as to completeness of bid items, quantity, format, format, etc. in the BOC Form considering that the electronic copy is prone to alterations during encoding. Any discrepancy on the contents (quantity and inclusive pay items) between the hard copy and electronic, the contents of the hard copy shall prevail.
- Bidder are not allowed to include any pay items that were not indicated in the form supplied B1 of Guidelines. In instances where necessary work items are inadvertently left out in BOC Form, a bidder should make a written query to the Bids and Awards Committee so that the same shall be addressed in the Bid Bulletin which will be issued to all participating bidders.
- All documents must be signed, and each and every page thereof must be initialed by the duly authorized representative(s) of the Bidder.
- Unit Price of the Purchase Item shall include the following:
 - Materials, fabrication and installation costs
 - Overhead expenses such as office expenses, supervision, transportation allowances, and bonding costs (Premium on CAR, Bid Security, Performance Security, Surety for advance payment, Warranty bond)
 - Contingencies, miscellaneous expenses and Contractor's Profit margin
- It is the responsibility of the Bidder to check the aforementioned completion provided herein.

Submitted by: _____
 (Name of Bidder / Company Name)

Prepared by: _____
 (Company Representative / Signature over printed name)

Address: _____

Telephone #: _____

Date: _____



Republic of the Philippines
SOCIAL SECURITY SYSTEM
 East Ave., Diliman, Quezon City

Project: **FRFR**
 Location: **SSS Tuguegarao, 3/F Robinsons Place Tuguegarao, Brgy. Torio, Tuguegarao City**

BILL OF QUANTITIES

ITEM	DESCRIPTION	QTY	UNIT	UNIT COST	VAT (12%)	TOTAL COST
(A)	(B)	(C)	(D)	(E)	(F)	(G)
1	MODULAR OFFICE SYSTEM					
	1. Branch Head Workstation (BHW)					
	a. Desk					
	1. 1 pc. Driveway Free-Standing Executive Table, 1800mm L x 750mm D x 750mm H in 30mm thick MDF Board (Laminate w/ Plastic Coarmental w/ Rotating Cover and 30mm thick MDF Board Side Support in HPL Finish					
	2. 1 pc. Side Return Table 1200mm L x 600mm D x 750mm H x 30mm thick MDF Board (Laminate w/ Plastic Coarmental w/ Rotating Cover, Double Metal Sheet in Powder Coated Finish Legs Support and Double Sheet Solidbody Panel in Powder Coated Finish	1.0	pc		-	-
	c. Accessories					
	1. 1 pc. Center Drawer, 360mm W x 400mm D x 100mm H					
	2. 1 pc. Reinforced Tray, Wood Panels					
	2. Assorted Branch Head Workstation (ABHW)					
	a. Module Panels & Supports					
	1. 1 pc. Polaris Screen Panel, Two-Tone, 1200mm W x 1300mm H x 30mm thick with Powder Coated Aluminum Panel Backing for Cable & Outlets and Coarrel Glass					
	2. 1 pc. Polaris Screen Panel, Two-Tone, 700mm W x 1300mm H x 30mm thick with Powder Coated Aluminum Panel Backing for Cable & Outlets and Coarrel Glass					
	3. 1 pc. Polaris Screen Panel, Two-Tone, 400mm W x 1300mm H x 30mm thick with Powder Coated Aluminum Panel Backing for Cable & Outlets and Coarrel Glass					
	4. 2 pc. Aluminum End Ties, 1000mm H	1.0	pc		-	-
	5. 1 pc. Corner Pad, 3-way, 1000mm H					
	b. Module Worktop					
	1. 1 pc. Rectangular Worktop, 1200mm L x 600mm W x 30mm thick MDF Board in HPL Finish, w/ 2 pcs. Plastic Coarmental w/ Rotating Cover					
	2. 1 pc. Rectangular Worktop, 1200mm L x 400mm W x 30mm thick MDF Board in HPL Finish, w/ 2 pcs. Plastic Coarmental w/ Rotating Cover					
	3. 1 pc. Panel Modesty Panel, 1000mm W x 400mm H x 30mm thick MDF Board in HPL Finish					
	c. Accessories					
	1. 1 unit Center Drawer, 360mm W x 400mm D x 100mm H					
	2. 1 unit Reinforced Tray, Wood Panels					
	3. Desktop Workstation (DHW 1)					
	a. Module Panels & Supports					
	1. 3 pc. Polaris Screen Panel, Two-Tone, 1200mm W x 1300mm H x 30mm thick with Powder Coated Aluminum Panel Backing for Cable & Outlets					
	2. 3 pc. Polaris Screen Panel, Two-Tone, 800mm W x 1300mm H x 30mm thick with Powder Coated Aluminum Panel Backing for Cable & Outlets					
	3. 3 pc. Polaris Screen Panel, Two-Tone, 400mm W x 1300mm H x 30mm thick with Powder Coated Aluminum Panel Backing for Cable & Outlets					
	4. 3 pc. Polaris Screen Panel, Monochrome, 1000mm W x 700mm H x 30mm thick with Powder Coated Aluminum Panel Backing for Cable & Outlets					
	5. 3 pc. Polaris Screen Panel, Two-Tone, 800mm W x 900mm H x 30mm thick with Powder Coated Aluminum Panel Backing for Cable & Outlets					
	6. 3 pc. Aluminum End Ties, 1000mm H	1.0	pc		-	-
	7. 3 pc. Aluminum End Ties, 800mm H					
	8. 3 pc. Aluminum End Ties, 400mm H					
	9. 3 pc. Aluminum End Ties, 1000mm H					
	10. 4 pc. Corner Pad, 3-way, 1000mm H					
	11. 3 pc. Corner Pad, 3-way, 800mm H					
	b. Module Worktop					
	1. 3 pc. Rectangular Worktop, 1200mm L x 600mm W x 30mm thick MDF Board in HPL Finish, w/ 2 pcs. Plastic Coarmental w/ Rotating Cover					
	2. 3 pc. Rectangular Worktop, 1200mm L x 400mm W x 30mm thick MDF Board in HPL Finish, w/ 2 pcs. Plastic Coarmental w/ Rotating Cover					
	c. Accessories					
	1. 3 unit Center Drawer, 360mm W x 400mm D x 100mm H					
	2. 3 unit Reinforced Tray, Wood Panels					
	4. Desktop Workstation (DHW 2)					
	a. Module Panels & Supports					
	1. 1 pc. Polaris Screen Panel, Two-Tone, 1200mm W x 1300mm H x 30mm thick with Powder Coated Aluminum Panel Backing for Cable & Outlets					
	2. 1 pc. Polaris Screen Panel, Two-Tone, 800mm W x 1300mm H x 30mm thick with Powder Coated Aluminum Panel Backing for Cable & Outlets					
	3. 1 pc. Polaris Screen Panel, Two-Tone, 400mm W x 1300mm H x 30mm thick with Powder Coated Aluminum Panel Backing for Cable & Outlets					
	4. 1 pc. Polaris Screen Panel, Two-Tone, 1000mm W x 900mm H x 30mm thick with Powder Coated Aluminum Panel Backing for Cable & Outlets					
	5. 1 pc. Polaris Screen Panel, Two-Tone, 800mm W x 700mm H x 30mm thick with Powder Coated Aluminum Panel Backing for Cable & Outlets					
	6. 1 pc. Aluminum End Ties, 1000mm H	1.0	pc		-	-
	7. 1 pc. Aluminum End Ties, 700mm H					
	8. 1 pc. Aluminum End Ties, 300mm H					
	9. 1 pc. Aluminum End Ties, 1000mm H					
	10. 2 pc. Corner Pad, 3-way, 1000mm H					
	11. 1 pc. Corner Pad, 3-way, 800mm H					

ITEM	DESCRIPTION			QTY	UNIT	UNIT COST	VM (13%)	FORM COST
(A)	(B)			(C)	(D)	(E)	(F)	(G)
	6. Module Worktop							
	1.	1	pc.	Rectangular Worktop, 1200mm L x 600mm W x 30mm H, MDF Based in HPL, Finish, w/ 2pc. Plastic Channel w/ Rotating Cover				
	2.	1	pc.	Rectangular Worktop, 1200mm L x 600mm W x 30mm H, MDF Based in HPL, Finish, w/ 2pc. Plastic Channel w/ Rotating Cover				
	6. Accessories							
	1.	1	unit	Center Drawer, 600mm W x 400mm D x 160mm H				
	2.	1	unit	Detachable Tray, Wood Finish				
	7. Section Head Workstation (20" H) 2-Drawer Back-to-back							
	a. Module Panels & Supports							
	1.	2	pc.	Polaris Screen Panel, Two-tone, 1200mm W x 1200mm H x 60mm H with Powder Coated Aluminum Panel Backing for Cable & Outlets				
	2.	2	pc.	Polaris Screen Panel, Two-tone, 600mm W x 1200mm H x 60mm H with Powder Coated Aluminum Panel Backing for Cable & Outlets				
	3.	4	pc.	Polaris Screen Panel, Two-tone, 600mm W x 1200mm H x 60mm H with Powder Coated Aluminum Panel Backing for Cable & Outlets				
	4.	4	pc.	Polaris Screen Panel, Two-tone, 1800mm W x 750mm H x 60mm H with Powder Coated Aluminum Panel Backing for Cable & Outlets				
	5.	4	pc.	Polaris Screen Panel, Two-tone, 600mm W x 900mm H x 60mm H with Powder Coated Aluminum Panel Backing for Cable & Outlets				
	6.	4	pc.	Aluminum End Ties, 1200mm H	20	sets		
	7.	4	pc.	Aluminum End Ties, 900mm H				
	8.	4	pc.	Aluminum End Ties, 1800mm H				
	9.	4	pc.	Aluminum End Ties, 600mm H				
	10.	4	pc.	Corner Pad, 3-way, 1200mm H				
	11.	4	pc.	Corner Pad, 2-way, 900mm H				
	b. Module Worktop							
	1.	4	pc.	Rectangular Worktop, 1200mm L x 600mm W x 30mm H, MDF Based in HPL, Finish, w/ 2pc. Plastic Channel w/ Rotating Cover				
	2.	4	pc.	Rectangular Worktop, 1200mm L x 600mm W x 30mm H, MDF Based in HPL, Finish, w/ 2pc. Plastic Channel w/ Rotating Cover				
	c. Accessories							
	1.	4	units	Center Drawer, 600mm W x 400mm D x 160mm H				
	2.	4	units	Detachable Tray, Wood Finish				
	8. Desk Workstation (20" H)							
	a. Module Panels & Supports							
	1.	14	pc.	Polaris Screen Panel, Two-tone, 1200mm W x 750mm H x 60mm H with Powder Coated Aluminum Panel Backing for Cable & Outlets	14.0	sets		
	2.	28	pc.	Polaris Screen Panel, Two-tone, 600mm W x 1000mm H x 60mm H with Powder Coated Aluminum Panel Backing for Cable & Outlets				
	3.	28	pc.	Aluminum End Ties, 900mm H				
	4.	28	pc.	Aluminum End Ties, 1800mm H				
	5.	28	pc.	Corner Pad, 2-way, 900mm H				
	b. Module Worktop							
	1.	14	pc.	Rectangular Worktop, 1200mm L x 600mm W x 30mm H, MDF Based in HPL, Finish, w/ 2pc. Plastic Channel w/ Rotating Cover				
	c. Accessories							
	1.	14	units	Detachable Tray, Wood Finish				
	9. Desk Workstation (20" H)							
	a. Module Panels & Supports							
	1.	4	pc.	Polaris Screen Panel, Two-tone, 1200mm W x 1200mm H x 60mm H with Powder Coated Aluminum Panel Backing for Cable & Outlets	4.0	sets		
	2.	12	pc.	Polaris Screen Panel, Two-tone, 600mm W x 900mm H x 60mm H with Powder Coated Aluminum Panel Backing for Cable & Outlets				
	3.	12	pc.	Aluminum End Ties, 900mm H				
	4.	12	pc.	Aluminum End Ties, 300mm H				
	5.	12	pc.	Corner Pad, 2-way, 1200mm H				
	b. Module Worktop							
	1.	4	pc.	Rectangular Worktop, 1200mm L x 600mm W x 30mm H, MDF Based in HPL, Finish, w/ 2pc. Plastic Channel w/ Rotating Cover				
	c. Accessories							
	1.	4	units	Detachable Tray, Wood Finish				
	10. Center Station (700mm table-top height)							
	a. Module Panels & Supports							
	1.	40	pc.	Polaris Screen Panel, Two-tone, 600mm W x 1100mm H x 30mm H with Powder Coated Aluminum Panel Backing for Cable & Outlets	40.0	sets		
	2.	20	pc.	Polaris Screen Panel, Two-tone, 700mm W x 1100mm H x 30mm H with Powder Coated Aluminum Panel Backing for Cable & Outlets				
	3.	40	pc.	Aluminum End Ties, 1100mm H				
	4.	40	pc.	Corner Pad, 2-way, 1100mm H				
	b. Module Worktop							
	1.	20	pc.	Rectangular Worktop, 700mm L x 600mm W x 30mm H, MDF Based in HPL, Finish, w/ 1 pc. Plastic Channel w/ Rotating Cover				
	c. Accessories							
	1.	20	sets	CPU Holder				
	2.	20	sets	Acrylic Plastic Divider				
	3.	20	sets	Full-size Drawer for Scanner				
	11. Computer Workstation (Per BMC)							
	a. Free-Standing Computer Table (F12), 1000mm L x 600mm D x 760mm H, 30mm H, MDF Based in HPL, Finish, Post-Formed Panel & Back Edges w/ 10.18 Legs Support Powder-Coated Finish w/ Integrated Cable Management Channel w/ Plastic Channel w/ Rotating Cover			20	units			
	12. iDCapture Workstation							
	a. Module Panels & Supports							
	1.	14	pc.	Polaris Screen Panel, Two-tone, 1200mm W x 1800mm H x 60mm H with Powder Coated Aluminum Panel Backing for Cable & Outlets	20	sets		
	2.	4	pc.	Corner Pad, 2-way, 1800mm H				
	3.	4	pc.	Aluminum End Ties, 1800mm H				
	13. Desk & Tables							
	a. Free-Standing Printer Table (F1) - 600mm L x 600mm D x 760mm H, MDF Based in HPL, Finish w/ Plastic Channel w/ Rotating Cover			20	units			
	b. Set of 4 - Module Seating Tables (600mm W x 1800mm L) supported by 40mm powder-coated tubular metal legs and levers			1.0	set			
	c. Round Conference Table, 700mm dia., MDF Based in HPL, Finish			1.0	unit			
SUB-TOTAL - LCP 1 - MODULAR OFFICE SYSTEM								

ITEM	DESCRIPTION	QTY	UNIT	UNIT COST	VAT (13%)	TOTAL COST
(A)	(B)	(C)	(D)	(E)	(F)	(G)
II - MATING FURNITURE						
1. 21 - Reception Desk, 2-piece, High Back		1.00	unit		-	-
2. 22 - Supervisor's Chair, 1-piece, Mid Back w/ Armrest		8.00	units		-	-
3. 23 - Non-Supervisor's Chair/Staff Chair, 1-piece, Low Back w/ Armrest		43.00	units		-	-
4. 24 - Teller's High Chair w/ Backing, 2-piece, Mid Back		1.00	unit		-	-
5. 25 - Guest Chair 1, 2-piece, Mid Back, Curved Top (For Reception) w/ Armrest		2.00	units		-	-
6. 26 - Guest Chair 2, 2-piece, Mid Back w/ Armrest, w/ Foam Cushion		22.00	units		-	-
7. 27 - 4-Drawer Gray Chair, 200mm x 400mm Base, Powder Coated Steel		18.00	units		-	-
SUB-TOTAL - LOT II - MATING FURNITURE						-
III - CONTRACT FURNITURE						
1. Reception Counter / Generalist Counter (GRC)						
a. Module Panels & Supports						
1.	10	mm	Side Support Panel, 600mm W x 1200mm H x 20mm Th, MDF Based in HP, Finish			
2.	4	mm	Front Module Panel, 1400mm W x 700mm H x 20mm Th, Marine Plywood w/ Horizontal Slats using 1/2" Th MDF Based in HP, Finish			
3.	4	mm	Side Module Panel, 1000mm W x 700mm H x 20mm Th, MDF Based in HP, Finish			
4.	10	mm	Side Support Panel, 400mm W x 700mm H x 20mm Th, MDF Based in PVC Non-Finish			
b. Module Worktop						
1.	4	mm	Rectangular Worktop, 1400mm L x 700mm W x 20mm Th, w/ Synthetic Stone (Acrylic) w/ Plastic Channel w/ Rotating Cover	4.0		-
2.	4	mm	Rectangular Worktop, 1000mm L x 400mm W x 20mm Th, w/ Synthetic Stone (Acrylic) w/ Plastic Channel w/ Rotating Cover			
3.	4	mm	Undercounter Ledge, 800mm L x 200mm W x 20mm Th, Marble Based in HP, Finish w/ Plastic Channel w/ Rotating Cover			
c. Accessories						
1.	4	units	4-Layer Bull-It Covers, 400mm W x 400mm D x 20mm Th, MDF Based in HP, Finish			
2.	4	units	100mm W x 100mm H 300 Logo in Stainless Steel Sheet			
3.	4	units	Recessed Tray, Hard Plastic			
2. Information Booth (IB)						
Dropped, 1800mm L x 1000mm W x 1100mm H x 15mm Th Marine Plywood Canopy w/ Bull-It Covers						
	1.0		unit			-
3. News Writing Counter (NWC)						
400mm W x 1800mm L x 1000mm H Rectangular Shaped Writing Counter made of MDF based slatted in HP, Solid and 400mm x 20mm rounded tubular slatted leg						
	1.0		unit			-
4. Guard's Pod						
Dropped Guard Station in Marine Plywood Canopy, HP, Finish w/ Bull-It Covers, Stainless Steel Slatted Leg & Recessed Logo						
	1.0		unit			-
5. Manager's Desk (Cabinet) (MC)						
1800mm W x 400mm D x 750 mm H 15mm Th Marine Plywood in PVC Non-Finish or Approved Equal						
	1.0		unit			-
SUB-TOTAL - LOT III - CONTRACT FURNITURE						-
IV - STEEL DRAWING, CABINETS & DRAWERS						
1. Open Steel Drawers (OSD) - 4 Layer, 600mm						
	17.0		units			-
2. Lateral Filing Cabinet, 4-Drawers						
	11.0		units			-
3. Mobile Padded Drawers 3-Drawers, 400mm W x 600mm D x 400mm H						
	25.0		units			-
SUB-TOTAL - LOT IV - STEEL DRAWING, CABINETS & DRAWERS						-
V - PERIOD CHARGES including Labor and Office Expenses						
						-
GRAND TOTAL						-

GENERAL CONDITIONS

- For uniformity and evaluation purposes, a bidder shall adhere to the herein prescribed format of BOC, specifically in the format for computation, given quantity and inclusive pay items. Any deviation from the format shall be a ground for disqualification of bid.
 - Fill up all required items/field in the BOC. Failure to indicate any of the following shall mean outright disqualification since bid is considered non-responsive:
 - * If item is given for free, indicate dash (-), zero (0) or free
 - * If the item is not applicable, indicate N/A
- Each bidder shall be provided with hard copy of the BOC Form (attached in the PBD) and an electronic copy for table and easier encoding. The hard copy shall serve as the bidder's reference as to completeness of work items, quantity, formula, format, etc. in the BOC Form considering that the electronic copy is prone to alterations during encoding. Any discrepancy on the contents (quantity and inclusive pay items) between the hard copy and electronic, the contents of the hard copy shall prevail.
- Bidder are not allowed to include any pay items that were not included in the form supplied BOC of Quantities. In instances where necessary work items are inadvertently left out in BOC Form, a bidder should make a written query to the Bids and Awards Committee so that the same shall be addressed in the Bid Bulletin which will be issued to all participating bidders.
 - All documents must be signed, and each and every page thereof must be initialed by the duly authorized representative(s) of the Bidder.
- Unit Price of the Furniture Item shall include the following:
 - Materials, fabrication and installation costs
 - Overhead expenses such as office expenses, supervision, transportation allowances, and financing costs (Premium on CAR, Bid Security, Performance Security, Surety for advance payment, Warranty bond)
 - Contingencies, miscellaneous expenses and Contractor's Profit margin
- It is the responsibility of the Bidder to check the official/contractor provided items.

Submitted by: _____
 (Name of Bidder / Company Name)

Prepared by: _____
 (Company Representative - Signature over printed name)

Address: _____

Telephone #: _____

Date: _____



Republic of the Philippines
SOCIAL SECURITY SYSTEM
 East Ave., Diliman, Quezon City

Project: **SEPLY, DELIVERY AND INSTALLATION OF MODULAR OFFICE SYSTEM AND FURNITURE FOR VARIOUS SSS BRANCH OFFICES**
 Location: **SSS Tobacco, GF - 3F, SPAINO Building, National Rd., Ingo, Tugos, Tobacco, Aliboy**

BILL OF QUANTITIES

ITEM	DESCRIPTION	QTY	UNIT	UNIT COST	VAJ (13%)	TOTAL COST
(A)	(B)	(C)	(D)	(E)	(F)	(G)
1	MODULAR OFFICE SYSTEM					
	1. Branch Head Workstation (BWH)					
	a. Desk					
	1. Driveway Free-Standing Executive Table, 1800mm L x 750mm D x 750mm H in 30mm thick MDF Board (tolerance w/ Plastic Coarmental w/ Rotating Cover and 30mm thick MDF Board Side Support in HPL Finish					
	2. Side Return Table 1200mm L x 600mm D x 750mm H in 30mm thick MDF Board (tolerance w/ Plastic Coarmental w/ Rotating Cover, Double Metal Sheet in Powder Coated Finish Legs Support and Double Sheet Solidbody Panel in Powder Coated Finish	1.0	set		-	-
	c. Accessories					
	1. Center Drawer, 600mm W x 400mm D x 100mm H					
	2. Desktop Tray, Wood Finish					
	2. Deskless Head Workstation (DHW 1)					
	a. Module Panels & Supports					
	1. Polaris Screen Panel, Two-Tone, 1000mm W x 1200mm H x 30mm thick with Powder Coated Aluminum Panel Backstay for Cable & Outlets					
	2. Polaris Screen Panel, Two-Tone, 600mm W x 1200mm H x 30mm thick with Powder Coated Aluminum Panel Backstay for Cable & Outlets					
	3. Polaris Screen Panel, Two-Tone, 600mm W x 1200mm H x 30mm thick with Powder Coated Aluminum Panel Backstay for Cable & Outlets					
	4. Polaris Screen Panel, Monochrome, 1000mm W x 750mm H x 30mm thick with Powder Coated Aluminum Panel Backstay for Cable & Outlets					
	5. Polaris Screen Panel, Two-Tone, 600mm W x 900mm H x 30mm thick with Powder Coated Aluminum Panel Backstay for Cable & Outlets					
	6. Aluminum End Ties, 1000mm H	20	sets		-	-
	7. Aluminum End Ties, 900mm H					
	8. Aluminum End Ties, 600mm H					
	9. Corner Pad, 2-way, 1000mm H					
	10. Corner Pad, 2-way, 900mm H					
	b. Module Worktop					
	1. Rectangular Worktop, 1000mm L x 600mm W x 30mm thick MDF Board in HPL Finish, w/ 2pins, Plastic Coarmental w/ Rotating Cover					
	2. Rectangular Worktop, 1000mm L x 600mm W x 30mm thick MDF Board in HPL Finish, w/ 2pins, Plastic Coarmental w/ Rotating Cover					
	c. Accessories					
	1. Center Drawer, 600mm W x 400mm D x 100mm H					
	2. Desktop Tray, Wood Finish					
	3. Deskless Head Workstation (DHW 2)					
	a. Module Panels & Supports					
	1. Polaris Screen Panel, Two-Tone, 1000mm W x 1200mm H x 30mm thick with Powder Coated Aluminum Panel Backstay for Cable & Outlets					
	2. Polaris Screen Panel, Two-Tone, 600mm W x 1200mm H x 30mm thick with Powder Coated Aluminum Panel Backstay for Cable & Outlets					
	3. Polaris Screen Panel, Two-Tone, 600mm W x 1200mm H x 30mm thick with Powder Coated Aluminum Panel Backstay for Cable & Outlets					
	4. Polaris Screen Panel, Two-Tone, 1000mm W x 900mm H x 30mm thick with Powder Coated Aluminum Panel Backstay for Cable & Outlets					
	5. Polaris Screen Panel, Two-Tone, 600mm W x 750mm H x 30mm thick with Powder Coated Aluminum Panel Backstay for Cable & Outlets					
	6. Aluminum End Ties, 1000mm H	20	sets		-	-
	7. Aluminum End Ties, 900mm H					
	8. Aluminum End Ties, 600mm H					
	9. Corner Pad, 2-way, 1000mm H					
	10. Corner Pad, 2-way, 900mm H					
	b. Module Worktop					
	1. Rectangular Worktop, 1000mm L x 600mm W x 30mm thick MDF Board in HPL Finish, w/ 2pins, Plastic Coarmental w/ Rotating Cover					
	2. Rectangular Worktop, 1000mm L x 600mm W x 30mm thick MDF Board in HPL Finish, w/ 2pins, Plastic Coarmental w/ Rotating Cover					
	c. Accessories					
	1. Center Drawer, 600mm W x 400mm D x 100mm H					
	2. Desktop Tray, Wood Finish					
	4. Deskless Head Workstation (DHW 3 w/ back panel)					
	a. Module Panels & Supports					
	1. Polaris Screen Panel, Two-Tone, 1000mm W x 1200mm H x 30mm thick with Powder Coated Aluminum Panel Backstay for Cable & Outlets					
	2. Polaris Screen Panel, Two-Tone, 600mm W x 1200mm H x 30mm thick with Powder Coated Aluminum Panel Backstay for Cable & Outlets					
	3. Polaris Screen Panel, Two-Tone, 600mm W x 1200mm H x 30mm thick with Powder Coated Aluminum Panel Backstay for Cable & Outlets					
	4. Polaris Screen Panel, Two-Tone, 1100mm W x 900mm H x 30mm thick with Powder Coated Aluminum Panel Backstay for Cable & Outlets					
	5. Polaris Screen Panel, Two-Tone, 1000mm W x 900mm H x 30mm thick with Powder Coated Aluminum Panel Backstay for Cable & Outlets					
	6. Polaris Screen Panel, Two-Tone, 600mm W x 750mm H x 30mm thick with Powder Coated Aluminum Panel Backstay for Cable & Outlets	1.0	set		-	-
	7. Aluminum End Ties, 1000mm H					
	8. Aluminum End Ties, 900mm H					
	9. Aluminum End Ties, 600mm H					
	10. Corner Pad, 2-way, 1000mm H					
	11. Corner Pad, 2-way, 900mm H					

ITEM	DESCRIPTION	QTY	UNIT	UNIT COST	VM (13%)	TOTAL COST
(A)	(B)	(C)	(D)	(E)	(F)	(G)
	6. Module Worktop					
1.	1 pks. Rectangular Worktop, 1200mm L x 600mm W x 30mm H, MDF Board In-HP, Finish w/ 2-pks. Plastic Cover w/ Rotating Cover					
2.	1 pks. Rectangular Worktop, 1200mm L x 600mm W x 30mm H, MDF Board In-HP, Finish w/ 2-pks. Plastic Cover w/ Rotating Cover					
	6. Accessories					
1.	1 unit. Corner Crocets, 600mm W x 600mm D x 160mm H					
2.	1 unit. Deckboard Tray, Hard Plastic					
	7. Section Head Workstation (20' H)					
	6. Module Panels & Supports					
1.	1 pks. Polaris Screen Panel, Teal-tone, 1000mm W x 1200mm H x 60mm H with Powder Coated Aluminum Panel Backing for Cables & Outlets					
2.	1 pks. Polaris Screen Panel, Teal-tone, 600mm W x 1200mm H x 60mm H with Powder Coated Aluminum Panel Backing for Cables & Outlets					
3.	1 pks. Polaris Screen Panel, Teal-tone, 600mm W x 1200mm H x 60mm H with Powder Coated Aluminum Panel Backing for Cables & Outlets					
4.	1 pks. Polaris Screen Panel, Teal-tone, 600mm W x 1200mm H x 60mm H with Powder Coated Aluminum Panel Backing for Cables & Outlets					
5.	1 pks. Polaris Screen Panel, Teal-tone, 700mm W x 1200mm H x 60mm H with Powder Coated Aluminum Panel Backing for Cables & Outlets					
6.	1 pks. Polaris Screen Panel, Teal-tone, 1800mm W x 700mm H x 60mm H with Powder Coated Aluminum Panel Backing for Cables & Outlets					
7.	1 pks. Polaris Screen Panel, Teal-tone, 600mm W x 600mm H x 60mm H with Powder Coated Aluminum Panel Backing for Cables & Outlets	1.0	unit			
8.	2 pks. Aluminum End Ties, 1000mm H					
9.	1 pks. Aluminum End Ties, 600mm H					
10.	1 pks. Aluminum End Ties, 600mm H					
11.	1 pks. Corner Pad, 2-way, 1000mm H					
12.	1 pks. Corner Pad, 2-way, 1000mm H					
13.	1 pks. Corner Pad, 2-way, 600mm H					
	6. Module Worktop					
1.	1 pks. Rectangular Worktop, 1800mm L x 600mm W x 30mm H, MDF Board In-HP, Finish w/ 2-pks. Plastic Cover w/ Rotating Cover					
2.	1 pks. Rectangular Worktop, 1200mm L x 600mm W x 30mm H, MDF Board In-HP, Finish w/ 2-pks. Plastic Cover w/ Rotating Cover					
	6. Accessories					
1.	1 unit. Corner Crocets, 600mm W x 600mm D x 160mm H					
2.	1 unit. Deckboard Tray, Hard Plastic					
	8. Staff Workstation (20' H)					
	6. Module Panels & Supports					
1.	4 pks. Polaris Screen Panel, Monochrome, 1200mm W x 700mm H x 60mm H with Powder Coated Aluminum Panel Backing for Cables & Outlets					
2.	8 pks. Polaris Screen panel, Teal-tone, 600mm W x 600mm H x 60mm H with Powder Coated Aluminum Panel Backing for Cables & Outlets	4.0	sets			
3.	8 pks. Aluminum End Ties, 600mm H					
4.	8 pks. Aluminum End Ties, 1000mm H					
5.	8 pks. Corner Pad, 2-way, 600mm H					
	6. Module Worktop					
1.	4 pks. Rectangular Worktop, 1200mm L x 600mm W x 30mm H, MDF Board In-HP, Finish w/ 2-pks. Plastic Cover w/ Rotating Cover					
	6. Accessories					
1.	4 units. Deckboard Tray, Hard Plastic					
	9. Staff Workstation (20' H)					
	6. Module Panels & Supports					
1.	8 pks. Polaris Screen Panel, Teal-tone, 1200mm W x 1200mm H x 60mm H with Powder Coated Aluminum Panel Backing for Cables & Outlets					
2.	10 pks. Polaris Screen panel, Teal-tone, 600mm W x 600mm H x 60mm H with Powder Coated Aluminum Panel Backing for Cables & Outlets	5.0	sets			
3.	10 pks. Aluminum End Ties, 600mm H					
4.	10 pks. Aluminum End Ties, 600mm H					
5.	10 pks. Corner Pad, 2-way, 1000mm H					
	6. Module Worktop					
1.	8 pks. Rectangular Worktop, 1200mm L x 600mm W x 30mm H, MDF Board In-HP, Finish w/ 2-pks. Plastic Cover w/ Rotating Cover					
	6. Accessories					
1.	8 units. Deckboard Tray, Hard Plastic					
	10. Center Station (700mm tabletop height)					
	6. Module Panels & Supports					
1.	20 pks. Polaris Screen Panel, Teal-tone, 600mm W x 1100mm H x 30mm H with Powder Coated Aluminum Panel Backing for Cables & Outlets					
2.	10 pks. Polaris Screen Panel, Teal-tone, 700mm W x 1100mm H x 30mm H with Powder Coated Aluminum Panel Backing for Cables & Outlets					
3.	20 pks. Aluminum End Ties, 1100mm H					
4.	20 pks. Corner Pad, 2-way, 1100mm H					
	6. Module Worktop					
1.	10 pks. Rectangular Worktop, 700mm L x 600mm W x 30mm H, MDF Board In-HP, Finish w/ 1 pks. Plastic Cover w/ Rotating Cover	10.0	sets			
	6. Accessories					
1.	10 sets. CPU Holder					
2.	10 sets. Acrylic Plastic Divider					
3.	10 sets. Pullout Drawer for Storage					
	11. ID Capture Workstation					
	6. Module Panels & Supports					
1.	2 pks. Polaris Screen Panel, Teal-tone, 1000mm W x 1800mm H x 60mm H with Powder Coated Aluminum Panel Backing for Cables & Outlets	1.0	set			
2.	2 pks. Corner Pad, 2-way, 1800mm H					
3.	2 pks. Aluminum End Ties, 1800mm H					
	12. Desks & Tables					
	6. Free-standing Private Table (PT) - 600mm L x 600mm D x 740mm H, MDF Board In-HP, Finish w/ Plastic Cover w/ Rotating Cover	2.0	units			
	6. Executive Conference Table (3-seater, Soft Drop w/ Wire Management) MDF Board In-HP, Finish	1.0	unit			
	6. Round Conference Table, 700mm dia., MDF Board In-HP, Finish	1.0	unit			
SUB-TOTAL - LCP 1 - MODULAR OFFICE SYSTEM						

ITEM	DESCRIPTION	QTY	UNIT	UNIT COST	VAT (13%)	TOTAL COST
(A)	(B)	(C)	(D)	(E)	(F)	(G)
II - MATING FURNITURE						
1.21	Executive Chair, 5-piece, High Back	1.00	unit		-	-
2.22	Supervisor's Chair, 5-piece, Mid Back w/ Armrest	4.00	units		-	-
3.23	Non-Supervisor's Chair/Staff Chair, 5-piece, Low Back w/ Armrest	17.00	units		-	-
4.24	Teller's High Chair w/ Backing, 2-piece, Mid Back	1.00	unit		-	-
5.25	Guest Chair 1, 2-piece, Mid Back, Curved Top (For Reception) w/ Armrest	2.00	units		-	-
6.26	Guest Chair 2, 2-piece, Mid Back w/ Armrest, w/ Foam Cushion	14.00	units		-	-
7.27	4-Drawer Gray Chair, 200mm x 400mm Base, Powder Coated Steel	8.00	units		-	-
SUB-TOTAL - LOT II - MATING FURNITURE						-
III - CONTRACT FURNITURE						
1. Reception Counter / Generalist Counter (GRC)						
a. Module Panels & Supports						
1.	8	pcs.	Side Support Panel, 600mm W x 1200mm H x 20mm Th, MDF Based in HP, Finish			
2.	4	pcs.	Front Module Panel, 1400mm W x 700mm H x 20mm Th, Marine Plywood w/ Horizontal Slats using 1/2" Th MDF Based in HP, Finish			
3.	4	pcs.	Side Module Panel, 1000mm W x 700mm H x 20mm Th, MDF Based in HP, Finish			
4.	8	pcs.	Side Support Panel, 400mm W x 700mm H x 20mm Th, MDF Based in PVC Pine Finish			
b. Module Worktop						
1.	4	pcs.	Rectangular Worktop, 1400mm L x 700mm W x 20mm Th, w/ Synthetic Stone (Acrylic) w/ Plastic Channel w/ Rotating Cover	4.0	unit	-
2.	4	pcs.	Rectangular Worktop, 1000mm L x 400mm W x 20mm Th, w/ Synthetic Stone (Acrylic) w/ Plastic Channel w/ Rotating Cover			
3.	4	pcs.	Undercounter Ledge, 800mm L x 200mm W x 20mm Th, Marble Based in HP, Finish w/ Plastic Channel w/ Rotating Cover			
c. Accessories						
1.	4	units	4-Layer Bull-It Covers, 400mm W x 400mm D x 20mm Th, MDF Based in HP, Finish			
2.	4	units	100mm W x 100mm H 300 Logo in Stainless Steel Sheet			
3.	4	units	Refracted Tray, Hard Plastic			
2. Information Booth (IB)						
Dropped, 1800mm L x 1000mm W x 1100mm H x 15mm Th Marine Plywood Canopies w/ Bull-It Covers						
	1.0	unit				-
3. News Writing Counter (NWC)						
400mm W x 1800mm L x 1000mm H Rectangular Shaped Writing Counter made of MDF based slatted in HP, Solid and 400mm x 20mm rounded tubular stainless steel						
	1.0	unit				-
4. Guard's Pod						
Dropped Guard Station in Marine Plywood Canopies, HP, Finish w/ Bull-It Covers, Stainless Steel Slatted & Refracted Logo						
	1.0	unit				-
5. Manager's Booth (MB)						
1800mm W x 400mm D x 700mm H 15mm Th Marine Plywood in PVC Pine Finish or Approved Equal						
	1.0	unit				-
SUB-TOTAL - LOT III - CONTRACT FURNITURE						-
IV - STEEL DRIVETS, CASHIERS & DRAWERS						
1.	Open Steel Drawers (OSD) - 4 Layer, 600mm	14.0	units		-	-
2.	Lateral Filing Cabinet, 4-Drawers	4.0	units		-	-
3.	Mobile Perforated Drawers 3-Drawers, 400mm W x 600mm D x 400mm H	14.0	units		-	-
SUB-TOTAL - LOT IV - STEEL DRIVETS, CASHIERS & DRAWERS						-
V - PERIOD CHARGES including Labor and Office Expenses						
GRAND TOTAL						-

GENERAL CONDITIONS

- For uniformity and evaluation purposes, a bidder shall adhere to the herein prescribed format of BOC, specifically to the format for computation, given quantity and inclusive pay items. Any deviation from the format shall be a ground for disqualification of bid.
 - If up of required items listed in the BOC, failure to indicate any of the following shall mean outright disqualification since bid is considered non-responsive
 - * If item is given for free, indicate dash (-), zero (0) or free
 - * If the item is not applicable, indicate N/A
- Each bidder shall be provided with hard copy of the BOC Form (attached in the PEO) and an electronic copy for table and easier encoding. The hard copy shall serve as the bidder's reference as to completeness of work items, quantity, formula, format, etc. in the BOC Form considering that the electronic copy is prone to alterations during encoding. Any discrepancy on the contents (quantity and inclusive pay items) between the hard copy and electronic, the contents of the hard copy shall prevail.
- Bidder are not allowed to include any pay items that were not included in the form supplied BOC of Quantities. In instances where necessary work items are inadvertently left out in BOC Form, a bidder should make a written query to the Bids and Awards Committee so that the same shall be addressed in the Bid Bulletin which will be issued to all participating bidders.
 - All documents must be signed, and each and every page thereof must be initialed by the duly authorized representative(s) of the Bidder.
- Unit Price of the Furniture Item shall include the following:
 - Materials, fabrication and installation costs
 - Overhead expenses such as office expenses, supervision, transportation allowances, and financing costs (Premium on CAR, Bid Security, Performance Security, Surety for advance payment, Warranty bond)
 - Contingencies, miscellaneous expenses and Contractor's Profit margin
- It is the responsibility of the Bidder to check the aforementioned computer provided items.

Submitted by: _____
 (Name of Bidder / Company Name)

Prepared by: _____
 (Company Representative - Signature over printed name)

Address: _____

Telephone #: _____

Date: _____



Republic of the Philippines
SOCIAL SECURITY SYSTEM
 East Ave., Diliman, Quezon City
 Tel. Nos. (632) 920-8401 * (632) 920-8464

Project : **SUPPLY, DELIVERY AND INSTALLATION OF MODULAR OFFICE SYSTEMS AND FURNITURE FOR VARIOUS SSS BRANCHES OFFICES**
Lot III - VISMIN BRANCHES

PRICE SCHEDULE(S)/ BID BREAKDOWN

	SSS BRANCH NAME	SUB-LIMIT	QTY	UNIT	TOTAL AMOUNT
1	SSS VALENCIA	2,971,934.00			
2	SSS BISLIG	2,970,562.07			
3	SSS DANA O	2,108,397.00			
4	SSS ZAMBOANGA	5,595,318.00			
5	SSS BAGO	3,275,950.00			
6	SSS SAGAY	2,429,983.49			
GRAND TOTAL					

Amount in Words	
------------------------	--

Note:

- 1 Any bid exceeding the sub-limit per branch shall not be accepted.
- 2 Bids must be inclusive of freight cost and all applicable charges and taxes.
- 3 Fill up all required items/field in the bid breakdown. Failure to indicate any of the following shall mean outright disqualification since bid is considered Non-Responsive.
 - If the item is given for free, indicate dash (-), zero (0) or free
 - If the item is not applicable, indicate N/A
- 4 All documents shall be signed, and each and every page thereof shall be initialed, by the duly authorized representative/s of the Bidder.
- 5 Warranty requirement is at no cost to SSS.

Name: _____

Legal capacity: _____

Signature: _____

Duly authorized to sign the Bid for and behalf of: _____



Project: **FRFR**
 Location: **SSS Valencia, 5/F Robinsons Place, Ingo, Bagonfias, Valencia City, Bukidnon**

BILL OF QUANTITIES

ITEM	DESCRIPTION		QTY	UNIT	UNIT COST	VAT (12%)	TOTAL COST
(A)	(B)		(C)	(D)	(E)	(F)	(G)
1	MODULAR OFFICE SYSTEMS						
	1. Branch Head Workstation (24H)						
	a.	1 pc.					
	D-shaped Free-Standing Executive Table, 1800mm L x 750mm D x 750mm H in 30mm thick MDF Board (tabletop w/ Plastic Chromel w/ Rotating Cover and 30mm thick MDF faced Side Support in HPL Finish						
	b.	1 pc.	1.0	pc		-	-
	Side Return Table 1200mm L x 600mm D x 750mm H in 30mm thick MDF Board (tabletop w/ Plastic Chromel w/ Rotating Cover, Double Metal Street in Powder Coated Finish Legs Support and Double Street Mobility Panel in Powder Coated Finish						
	c. Accessories						
	1.	1 pc.					
	Center Drawer, 360mm W x 400mm D x 100mm H						
	2.	1 pc.					
	Reinforced Tray, Head Panel						
	2. Desktop Head Workstation (24H-1)						
	a. Module Panels & Supports						
	1.	4 pcs.					
	Polarkit Screen Panel, Two-tone, 1200mm W x 1200mm H x 30mm thick with Powder Coated Aluminum Panel Backery for Cable & Outlets						
	2.	4 pcs.					
	Polarkit Screen Panel, Two-tone, 600mm W x 1200mm H x 30mm thick with Powder Coated Aluminum Panel Backery for Cable & Outlets						
	3.	4 pcs.					
	Polarkit Screen Panel, Two-tone, 600mm W x 1200mm H x 30mm thick with Powder Coated Aluminum Panel Backery for Cable & Outlets						
	4.	4 pcs.					
	Polarkit Screen Panel, Monochrome, 1000mm W x 700mm H x 30mm thick with Powder Coated Aluminum Panel Backery for Cable & Outlets						
	5.	4 pcs.					
	Polarkit Screen Panel, Two-tone, 600mm W x 900mm H x 30mm thick with Powder Coated Aluminum Panel Backery for Cable & Outlets						
	6.	4 pcs.					
	Aluminum Brad Nuts, 1000mm H		4.0	pc		-	-
	7.	4 pcs.					
	Aluminum Brad Nuts, 900mm H						
	8.	4 pcs.					
	Aluminum Brad Nuts, 600mm H						
	9.	4 pcs.					
	Aluminum Brad Nuts, 300mm H						
	10.	8 pcs.					
	Corner Pad, 3-way, 1000mm H						
	11.	4 pcs.					
	Corner Pad, 3-way, 900mm H						
	b. Module Worktop						
	1.	4 pcs.					
	Rectangular Worktop, 1200mm L x 600mm W x 30mm thick MDF Board in HPL Finish, w/ 2 (top, Plastic Chromel w/ Rotating Cover						
	2.	4 pcs.					
	Rectangular Worktop, 1200mm L x 600mm W x 30mm thick MDF Board in HPL Finish, w/ 2 (top, Plastic Chromel w/ Rotating Cover						
	c. Accessories						
	1.	4 units					
	Center Drawers, 360mm W x 400mm D x 100mm H						
	2.	4 units					
	Reinforced Tray, Head Panel						
	3. Desktop Head Workstation (24H-2) 2-Drawer Desk for back						
	a. Module Panels & Supports						
	1.	2 pcs.					
	Polarkit Screen Panel, Two-tone, 1200mm W x 1200mm H x 30mm thick with Powder Coated Aluminum Panel Backery for Cable & Outlets						
	2.	2 pcs.					
	Polarkit Screen Panel, Two-tone, 600mm W x 1200mm H x 30mm thick with Powder Coated Aluminum Panel Backery for Cable & Outlets						
	3.	4 pcs.					
	Polarkit Screen Panel, Two-tone, 600mm W x 1200mm H x 30mm thick with Powder Coated Aluminum Panel Backery for Cable & Outlets						
	4.	4 pcs.					
	Polarkit Screen Panel, Two-tone, 1000mm W x 700mm H x 30mm thick with Powder Coated Aluminum Panel Backery for Cable & Outlets						
	5.	4 pcs.					
	Polarkit Screen Panel, Two-tone, 600mm W x 900mm H x 30mm thick with Powder Coated Aluminum Panel Backery for Cable & Outlets						
	6.	4 pcs.					
	Aluminum Brad Nuts, 1000mm H		2.0	pc		-	-
	7.	4 pcs.					
	Aluminum Brad Nuts, 900mm H						
	8.	4 pcs.					
	Aluminum Brad Nuts, 300mm H						
	10.	4 pcs.					
	Corner Pad, 3-way, 1000mm H						
	11.	4 pcs.					
	Corner Pad, 3-way, 900mm H						
	b. Module Worktop						
	1.	4 pcs.					
	Rectangular Worktop, 1200mm L x 600mm W x 30mm thick MDF Board in HPL Finish, w/ 2 (top, Plastic Chromel w/ Rotating Cover						
	2.	4 pcs.					
	Rectangular Worktop, 1200mm L x 600mm W x 30mm thick MDF Board in HPL Finish, w/ 2 (top, Plastic Chromel w/ Rotating Cover						
	c. Accessories						
	1.	4 units					
	Center Drawers, 360mm W x 400mm D x 100mm H						
	2.	4 units					
	Reinforced Tray, Head Panel						
	4. Desk Workstation (24H-1)						
	a. Module Panels & Supports						
	1.	10 pcs.					
	Polarkit Screen Panel, Monochrome, 1000mm W x 700mm H x 30mm thick with Powder Coated Aluminum Panel Backery for Cable & Outlets						
	2.	20 pcs.					
	Polarkit Screen panel, Two-tone, 600mm W x 900mm H x 30mm thick with Powder Coated Aluminum Panel Backery for Cable & Outlets						
	3.	20 pcs.					
	Aluminum Brad Nuts, 900mm H		10.0	pc		-	-
	4.	20 pcs.					
	Aluminum Brad Nuts, 300mm H						
	5.	20 pcs.					
	Corner Pad, 3-way, 900mm H						
	b. Module Worktop						
	1.	10 pcs.					
	Rectangular Worktop, 1200mm L x 600mm W x 30mm thick MDF Board in HPL Finish, w/ 2 (top, Plastic Chromel w/ Rotating Cover						
	c. Accessories						
	1.	10 units					
	Reinforced Tray, Head Panel						

ITEM	DESCRIPTION	QTY	UNIT	UNIT COST	VAT (13%)	TOTAL COST
(A)	(B)	(C)	(D)	(E)	(F)	(G)
E. Staff Workstation (2x2)						
a. Module Panels & Supports						
1.	4	PPA	Polaris Screen Panel, Two-tone, 1200mm W x 1200mm H x 30mm Bx with Powder Coated Aluminium Panel Backstay for Cable & Outlets			
2.	8	PPA	Polaris Screen panel, Two-tone, 600mm W x 600mm H x 30mm Bx with Powder Coated Aluminium Panel Backstay for Cable & Outlets			
3.	8	gpc	Aluminium End Ties, 600mm H	4.0		
4.	8	gpc	Aluminium End Ties, 300mm H			
5.	8	gpc	Corner Post, 2-way, 1200mm H			
b. Module Worktop						
1.	4	gpc	Rectangular Worktop, 1200mm L x 600mm W x 30mm Bx MDF Board in HP, Finish w/ 2pts. Plastic Channel w/ Rotating Cover			
c. Accessories						
1.	4	units	Desktop Tray, Metal Finish			
E.2- Center Station (270mm tabletop height)						
a. Module Panels & Supports						
1.	14	PPA	Polaris Screen Panel, Two-tone, 600mm W x 1100mm H x 30mm Bx with Powder Coated Aluminium Panel Backstay for Cable & Outlets			
2.	7	PPA	Polaris Screen Panel, Two-tone, 700mm W x 1100mm H x 30mm Bx with Powder Coated Aluminium Panel Backstay for Cable & Outlets			
3.	14	gpc	Aluminium End Ties, 1100mm H	7.0		
4.	14	gpc	Corner Post, 2-way, 1100mm H			
b. Module Worktop						
1.	7	PPA	Rectangular Worktop, 700mm L x 600mm W x 30mm Bx MDF Board in HP, Finish w/ 1 pt. Plastic Channel w/ Rotating Cover			
c. Accessories						
1.	7	units	CPU Holder			
2.	7	units	Acrylic Plastic Divider			
3.	7	units	Pushed Drawer for Scanner			
F. Computer Workstation (For CRM)						
Free Standing Computer Table (F12), 1000mm L x 600mm D x 750mm H x 30mm Bx MDF Board in HP, Finish, Post-Borned Panel & Back Edges w/ 2x 18 Legs Support Powder-Coated Finish w/ Integrated Cable Management Channel w/ Plastic Channel w/ Rotating Cover						
	10	units				
G. ID Capture Workstation						
a. Module Panels & Supports						
1.	14	PPA	Polaris Screen Panel, Two-tone, 1000mm W x 1800mm H x 30mm Bx with Powder Coated Aluminium Panel Backstay for Cable & Outlets	10		
2.	4	gpc	Corner Post, 2-way, 1800mm H			
3.	4	gpc	Aluminium End Ties, 1800mm H			
H. Desk & Tables						
Free Standing Printer Table (P1) - 800mm L x 600mm D x 740mm H MDF Board in HP, Finish w/ Plastic Channel w/ Rotating Cover						
	10	units				
Executive Conference Table (Executive, Roof Slope w/ Wire Management) MDF Board in HP, Finish						
	1.0	unit				
Round Conference Table, 600mm dia, MDF Board in HP, Finish						
	1.0	unit				
SUB-TOTAL - LOT 1 - MODULAR OFFICE SYSTEMS						
II. METRO FURNITURE						
1. D1 - Reception Desk, System, High Back						
				1.00		
2. D2 - Supervisor's Chair, System, Mid Back w/ Armrest						
				8.00		
3. D3 - Non-Supervisor's Chair/Staff Chair, System, Low Back w/ Armrest						
				10.00		
4. D4 - Teller's High Chair w/ Footing, 2 pieces, Mid Back						
				1.00		
5. D5 - Guest Chair 1, 2 pieces, Mid Back, Curved Top (For Reception) w/ Armrest						
				3.00		
6. D6 - Guest Chair 2, 2 pieces, Mid Back w/ Armrest, w/ Foam Cushion						
				18.00		
7. D7 - 8-Seater Dining Chair, 180mm x 60mm x 60mm, Powder Coated Steel						
				3.0		
8. D8 - 4-Seater Dining Chair, 200mm x 60mm x 60mm, Powder Coated Steel						
				3.0		
SUB-TOTAL - LOT II - BATHING FURNITURE						
III. CONTRACT FURNITURE						
1. Reception Counter / Generalist Counter (2x2)						
a. Module Panels & Supports						
1.	8	PPA	Side Support Panel, 600mm W x 1200mm H x 30mm Bx, MDF Board in HP, Finish			
2.	4	PPA	Panel Modesty Panel, 1400mm W x 700mm H x 30mm Bx, Marine Plywood w/ Horizontal Strips using 1/2" Bx MDF Board in HP, Finish			
3.	4	PPA	Side Modesty Panel, 1000mm W x 700mm H x 30mm Bx, MDF Board in HP, Finish			
4.	8	gpc	Side Support Panel, 600mm W x 700mm H x 30mm Bx, MDF Board in PVC Film Finish			
b. Module Worktop						
1.	4	PPA	Rectangular Worktop, 1400mm L x 700mm W x 30mm Bx, w/ Synthetic Stone (Acrylic) w/ Plastic Channel w/ Rotating Cover	4.0		
2.	4	PPA	Rectangular Worktop, 1000mm L x 600mm W x 30mm Bx, w/ Synthetic Stone (Acrylic) w/ Plastic Channel w/ Rotating Cover			
3.	4	gpc	Undercounter ledge, 600mm L x 300mm W x 30mm Bx, Particle Board in HP, Finish w/ Plastic Channel w/ Rotating Cover			
c. Accessories						
1.	4	units	4-Layer Ball-in-Drawer, 600mm W x 600mm D x 30mm Bx, MDF Board in HP, Finish			
2.	4	units	120mm H x 100mm H 300 Logo in Stainless Steel Sheet			
3.	4	units	Desktop Tray, Metal Finish			
2. Information Booth (Info)						
Drillaged, 1800mm L x 1000mm W x 1100mm H x 30mm Bx Marine Plywood Cabinet w/ Ball-in-Drawers						
	1.0	unit				
3. Reception Counter (PVC)						
600mm W x 1800mm L x 1500mm H Rectangular Shaped Milling Counter made of MDF Board tabletop in HP, Finish and 40mm powder-coated tubular steel leg						
	1.0	unit				
4. Guard's Post						
Drillaged Guard Station in Marine Plywood Cabinet, HP, Finish w/ Ball-in-Drawers, Stainless Steel Milling & Endcapped Legs						
	1.0	unit				
5. Manager's Desk (Cabinet) (PVC)						
1800mm W x 600mm D x 750mm H 30mm Bx Marine Plywood in PVC Film Finish or Approved Equal						
	1.0	unit				
SUB-TOTAL - LOT III - CONTRACT FURNITURE						

ITEM	DESCRIPTION	QTY	UNIT	UNIT COST	VAT (13%)	TOTAL COST
(A)	(B)	(C)	(D)	(E)	(F)	(G)
DRIVE, DRIVE, CABINET & DRAWER						
	1. Open Steel Drawers (OSD) 400mm (2x 2)	10	units		-	-
	2. Lateral Filing Cabinet 400mm	10	units		-	-
	3. Mobile Pedestal Drawers 3-Drawers, 400mm W x 600mm D x 800mm H	10	units		-	-
	TOTAL COST - DRIVE, DRIVE, CABINET & DRAWER					-
PERCENT CHARGES including labor and Other Expenses						
						-
						GRAND TOTAL

GENERAL CONDITIONS

- For uniformity and evaluation purposes, a bidder shall adhere to the terms prescribed herein of BOC, specifically to the formula for computation, given quantity and exclusive pay items. Any deviation from the format shall be a ground for disqualification of bid.
 - Fill up all required items/field in the BOC. Failure to indicate any of the following shall mean outright disqualification since bid is considered non-responsive.
 - * If item is given for free, indicate dash (-), zero (0) or free.
 - * If the item is not applicable, indicate N/A.
- Each bidder shall be provided with hard copy of the BOC Form (attached in the PEO) and an electronic copy for later and easier encoding. The hard copy shall serve as the bidder's reference as to completeness of each item, quantity, formula, format, etc. in the BOC Form considering that the electronic copy is prone to alterations during encoding. Any discrepancy on the contents (quantity and exclusive pay items) between the hard copy and electronic, the contents of the hard copy shall prevail.
- Bidder are not allowed to include any pay items that were not indicated in the form supplied. In instances where necessary work items are inadvertently left out in BOC Form, a bidder should make a written query to the Bids and Awards Committee so that the same shall be addressed in the Bid Sublet which will be issued to all participating bidders.
- All documents must be signed, and each and every page thereof must be initialed by the duly authorized representative/s of the Bidder.
 - Unit Price of the purchase item shall include the following:
 - Materials, fabrication and installation costs
 - Overhead expenses such as office expenses, supervision, transportation allowances, and bonding costs (Premium on CAR, Bid Security, Performance Security, Surety for advance payment, Warranty bond)
 - Contingencies, miscellaneous expenses and Contractor's Profit margin
- It is the responsibility of the Bidder to check the official bid computer provided herein.

Submitted by: _____
(Name of Bidder / Company Name)

Prepared by: _____
(Company Representative / Signature over printed name)

Address: _____

Telephone #: _____
Date: _____



Republic of the Philippines
SOCIAL SECURITY SYSTEM
 East Ave., Diliman, Quezon City

Project: **SEPPY, DELIVERY AND INSTALLATION OF MODULAR OFFICE SYSTEM AND FURNITURE FOR VARIOUS SSS BRANCH OFFICES**
 Location: **SSS Balig, Hapales Building, Epifanio St., Mangagay, Balig City, Sulagoo del Sur**

BILL OF QUANTITIES

ITEM	DESCRIPTION		QTY	UNIT	UNIT COST	VAT (12%)	TOTAL COST
(A)	(B)		(C)	(D)	(E)	(F)	(G)
1	MODULAR OFFICE SYSTEM						
	1. Branch Head Workstation (BHW)						
	a.	1 pc.					
	Divan-style Free-Standing Executive Table, 1800mm L x 750mm D x 750mm H in 30mm thick MDF Board (tolerance +/- 0.5mm) Chromel w/ Rotating Cover and 30mm thick MDF Board Side Support in RFL Finish						
	b.	1 pc.	1.0	ml		-	-
	Side Return Table 1200mm L x 600mm D x 750mm H in 30mm thick MDF Board (tolerance +/- 0.5mm) Chromel w/ Rotating Cover, 2x18 Metal Steel in Powder Coated Finish Legs Support and 2x20 Steel Meshbody Panel in Powder Coated Finish						
	c. Accessories						
	1.	1 pc.					
	Center Drawer, 360mm W x 400mm D x 100mm H						
	2.	1 pc.					
	Reinforced Tray, Metal Finish						
	2. Desktop Head Workstation (DHW-1)						
	a. Modular Panels & Supports						
	1.	4 ppa.					
	Polaris Screen Panel, Teal-tone, 1300mm W x 1300mm H x 30mm thick with Powder Coated Aluminum Panel Backing for Cable & Outlets						
	2.	4 ppa.					
	Polaris Screen Panel, Teal-tone, 800mm W x 1300mm H x 30mm thick with Powder Coated Aluminum Panel Backing for Cable & Outlets						
	3.	4 ppa.					
	Polaris Screen Panel, Teal-tone, 600mm W x 1300mm H x 30mm thick with Powder Coated Aluminum Panel Backing for Cable & Outlets						
	4.	4 ppa.					
	Polaris Screen Panel, Marablon, 1000mm W x 700mm H x 30mm thick with Powder Coated Aluminum Panel Backing for Cable & Outlets						
	5.	4 ppa.					
	Polaris Screen Panel, Teal-tone, 800mm W x 900mm H x 30mm thick with Powder Coated Aluminum Panel Backing for Cable & Outlets						
	6.	4 ppa.					
	Aluminum End Trim, 1200mm H		4.0	mls		-	-
	7.	4 ppa.					
	Aluminum End Trim, 900mm H						
	8.	4 ppa.					
	Aluminum End Trim, 600mm H						
	9.	4 ppa.					
	Aluminum End Trim, 300mm H						
	10.	8 ppa.					
	Corner Pad, 3-way, 1200mm H						
	11.	4 ppa.					
	Corner Pad, 3-way, 900mm H						
	b. Modular Worktop						
	1.	4 ppa.					
	Rectangular Worktop, 1000mm L x 600mm W x 30mm thick MDF Board in RFL Finish, w/ 2x18 Polaris Chromel w/ Rotating Cover						
	2.	4 ppa.					
	Rectangular Worktop, 1200mm L x 600mm W x 30mm thick MDF Board in RFL Finish, w/ 2x18 Polaris Chromel w/ Rotating Cover						
	c. Accessories						
	1.	4 units					
	Center Drawer, 360mm W x 400mm D x 100mm H						
	2.	4 units					
	Reinforced Tray, Metal Finish						
	3. Desktop Workstation (DHW)						
	a. Modular Panels & Supports						
	1.	1 ppa.					
	Polaris Screen Panel, Teal-tone, 1300mm W x 1300mm H x 30mm thick with Powder Coated Aluminum Panel Backing for Cable & Outlets						
	2.	2 ppa.					
	Polaris Screen Panel, Teal-tone, 600mm W x 1300mm H x 30mm thick with Powder Coated Aluminum Panel Backing for Cable & Outlets						
	3.	1 ppa.					
	Polaris Screen Panel, Teal-tone, 700mm W x 1300mm H x 30mm thick with Powder Coated Aluminum Panel Backing for Cable & Outlets						
	4.	1 ppa.					
	Polaris Screen Panel, Teal-tone, 400mm W x 1300mm H x 30mm thick with Powder Coated Aluminum Panel Backing for Cable & Outlets						
	5.	1 ppa.					
	Polaris Screen Panel, Marablon, 1000mm W x 700mm H x 30mm thick with Powder Coated Aluminum Panel Backing for Cable & Outlets						
	6.	1 ppa.					
	Polaris Screen Panel, Teal-tone, 800mm W x 900mm H x 30mm thick with Powder Coated Aluminum Panel Backing for Cable & Outlets		1.0	ml		-	-
	7.	1 ppa.					
	Aluminum End Trim, 1200mm H						
	8.	1 ppa.					
	Aluminum End Trim, 900mm H						
	9.	1 ppa.					
	Aluminum End Trim, 300mm H						
	10.	2 ppa.					
	Corner Pad, 3-way, 1200mm H						
	11.	1 ppa.					
	Corner Pad, 3-way, 900mm H						
	b. Modular Worktop						
	1.	1 ppa.					
	Rectangular Worktop, 1000mm L x 600mm W x 30mm thick MDF Board in RFL Finish, w/ 2x18 Polaris Chromel w/ Rotating Cover						
	2.	1 ppa.					
	Rectangular Worktop, 1200mm L x 600mm W x 30mm thick MDF Board in RFL Finish, w/ 2x18 Polaris Chromel w/ Rotating Cover						
	c. Accessories						
	1.	1 unit					
	Center Drawer, 360mm W x 400mm D x 100mm H						
	2.	1 unit					
	Reinforced Tray, Metal Finish						
	4. Staff Workstation (SW-1)						
	a. Modular Panels & Supports						
	1.	11 ppa.					
	Polaris Screen Panel, Marablon, 1200mm W x 700mm H x 30mm thick with Powder Coated Aluminum Panel Backing for Cable & Outlets						
	2.	22 ppa.					
	Polaris Screen panel, Teal-tone, 800mm W x 900mm H x 30mm thick with Powder Coated Aluminum Panel Backing for Cable & Outlets						
	3.	22 ppa.					
	Aluminum End Trim, 900mm H		11.0	mls		-	-
	4.	22 ppa.					
	Aluminum End Trim, 300mm H						
	5.	22 ppa.					
	Corner Pad, 3-way, 900mm H						
	b. Modular Worktop						
	1.	11 ppa.					
	Rectangular Worktop, 1200mm L x 600mm W x 30mm thick MDF Board in RFL Finish, w/ 2x18 Polaris Chromel w/ Rotating Cover						
	c. Accessories						
	1.	11 units					
	Reinforced Tray, Metal Finish						

ITEM	DESCRIPTION	QTY	UNIT	UNIT COST	VM (137%)	FORMAL COST
(A)	(B)	(C)	(D)	(E)	(F)	(G)
6. B-Counter Station (9'00mm Inset top height)						
a. Module Panels & Supports						
1.	20	pts.	Point's Screen Panel, Teal/White, 800mm W x 1100mm H x 30mm TH with Powder Coated Aluminum Panel Backing for Cables & Outlets			
2.	10	pts.	Point's Screen Panel, Teal/White, 700mm W x 1100mm H x 30mm TH with Powder Coated Aluminum Panel Backing for Cables & Outlets			
3.	20	pts.	Aluminum End Trim, 1100mm H	10.0		-
4.	20	pts.	Corner Post, 2-way, 1100mm H			-
b. Module Worktop						
1.	10	pts.	Rectangular Worktop, 1000mm L x 800mm W x 30mm TH, MDF Based in HPL Finish w/ 1/2" Plastic Grannal w/ Rotating Cover			
c. Accessories						
1.	10	sets	CPU Holder			
2.	10	sets	Acrylic Plastic Divider			
3.	10	sets	Full-rod Cover for Bottom			
7. Computer Workstation (Per BMC)						
a. Free-Standing Computer Table (FST), 1000mm L x 600mm D x 740mm H, MDF Based in HPL Finish, Post-Formed Panel & Back Edges w/ Co. 18 Legs Support Powder-Coated Finish w/ Integrated Cable Management Channel w/ Plastic Grannal w/ Rotating Cover						
1.0				1.0		-
7. 10 Capture Workstation						
a. Module Panels & Supports						
1.	7	pts.	Point's Screen Panel, Teal/White, 1000mm W x 1400mm H x 30mm TH with Powder Coated Aluminum Panel Backing for Cables & Outlets	1.0		-
2.	3	pts.	Corner Post, 2-way, 1400mm H			-
3.	3	pts.	Aluminum End Trim, 1400mm H			-
8. Desks & Tables						
a. Free-Standing Write Table (FT) - 800mm L x 600mm D x 740mm H, MDF Based in HPL Finish w/ Plastic Grannal w/ Rotating Cover						
1.0				1.0		-
b. Executive Conference Table (Executive), Solid Maple w/ Wire Management) MDF Based in HPL Finish						
1.0				1.0		-
c. Round Conference Table, 1000mm dia., MDF Based in HPL Finish						
1.0				1.0		-
SUB-TOTAL - LOT I - MODULAR OFFICE SYSTEM						
II. BATHING FURNITURE						
1. 21 - Executive Chair, 2-piece, High Back						
				1.00		-
2. 22 - Supervisor's Chair, 1-piece, Mid Back w/ Armrest						
				4.00		-
3. 23 - Main Supervisor's Chair/Staff Chair, 1-piece, Low Back w/ Armrest						
				20.00		-
4. 24 - Teller's High Chair w/ Footing, 2-piece, Mid Back						
				3.00		-
5. 25 - Ovoid Chair 1, 2-piece, Mid Back, Conference Table (For Resolute) w/ Armrest						
				3.00		-
6. 26 - Ovoid Chair 2, 2-piece, Mid Back w/ Armrest, w/ Room Condition						
				11.00		-
7. 27 - 4-Wheeler Seating Chair, 200mm x 400mm Base, Powder Coated Steel						
				9.0		-
SUB-TOTAL - LOT II - BATHING FURNITURE						
III. CONTRACT FURNITURE						
1. Reception Counter / Customer Counter (2x2)						
a. Module Panels & Supports						
1.	8	pts.	Side Support Panel, 800mm W x 1200mm H x 30mm TH, MDF Based in HPL Finish			
2.	4	pts.	Front Module Panel, 1400mm W x 700mm H x 30mm TH, Marine Plywood w/ Horizontal Strips using 1/2" TH, MDF Based in HPL Finish			
3.	4	pts.	Side Module Panel, 1000mm W x 700mm H x 30mm TH, MDF Based in HPL Finish			
4.	8	pts.	Side Support Panel, 600mm W x 700mm H x 30mm TH, MDF Based in PVC Film Finish	4.0		-
b. Module Worktop						
1.	4	pts.	Rectangular Worktop, 1400mm L x 700mm W x 30mm TH, w/ Synthetic Stone (Acrylic) w/ Plastic Grannal w/ Rotating Cover			
2.	4	pts.	Rectangular Worktop, 1000mm L x 600mm W x 30mm TH, w/ Synthetic Stone (Acrylic) w/ Plastic Grannal w/ Rotating Cover			
3.	4	pts.	Undercounter ledge, 800mm L x 200mm W x 20mm TH, Particle Board in HPL Finish w/ Plastic Grannal w/ Rotating Cover			
c. Accessories						
1.	4	sets	4-Layer Bull-in Drawer, 400mm W x 600mm D x 30mm TH, MDF Based in HPL Finish			
2.	4	sets	120mm W x 100mm H 100 Legs in Stainless Steel Steel			
3.	4	sets	Replaced Tray, Hard Plastic			
2. Information Booth (Info)						
Dropped, 1800mm L x 1000mm W x 1100mm H x 30mm TH, Marine Plywood Corcase w/ Bull-in Drawers						
1.0				1.0		-
3. News Writing Counter (NWC)						
400mm W x 1800mm L x 1000mm H Rectangular Shaped Writing Counter made of MDF based tabletop in HPL Finish and aluminum-coated tubular decking leg						
2.0				2.0		-
4. Guard's Post						
Dropped Guard Station in Marine Plywood Corcase, HPL Finish w/ Bull-in Drawers, Stainless Steel Welding & Reinforced Legs						
1.0				1.0		-
5. Manager's Desk Cabinet (MDC)						
1800mm W x 600mm D x 740mm H 30mm TH Marine Plywood in PVC Film Finish or Approved Equal						
1.0				1.0		-
SUB-TOTAL - LOT III - CONTRACT FURNITURE						
IV. TRIM, DRIVE, CABINETS & DRAWERS						
1. Open Steel Drawers (OSD), 3-piece, Co. M						
				10.0		-
2. Lateral Filing Cabinet, 4-Drawers						
				99.0		-
3. Mobile Perforated Drawers, 3-Drawers, 600mm W x 600mm D x 600mm H						
				14.0		-
SUB-TOTAL - LOT IV - TRIM, DRIVE, CABINETS & DRAWERS						
V. PERIOD CHARGES including Labor and Other Expenses						
GRAND TOTAL						

ITEM	DESCRIPTION	QTY	UNIT	UNIT COST	9% (10%)	TOTAL COST
(A)	(B)	(C)	(D)	(E)	(F)	(G)

GENERAL CONDITIONS

1. For uniformity and evaluation purposes, a bidder shall adhere to the herein prescribed format of BOC, specifically to the format for computation, given quantity and inclusive pay items. Any deviation from the format shall be a ground for disqualification of bid.
 - 1.1 Fill up all required items/field in the BOC. Failure to indicate any of the following shall mean outright disqualification since bid is considered nonresponsive:
 - * If item is given for free, indicate dash (-), zero (0) or free
 - * If the item is not applicable, indicate N/A
2. Each bidder shall be provided with hard copy of the BOC Form (attached in the PEO) and an electronic copy for hard and master encoding. The hard copy shall serve as the bidder's reference as to completeness of each item, quantity, formula, format, etc. in the BOC Form considering that the electronic copy is prone to alterations during encoding. Any discrepancy on the contents (specifically on the quantity and inclusive pay items) between the hard copy and electronic, the contents of the hard copy shall prevail.
3. Bidder are not allowed to include any pay items that were not indicated in the form supplied Bill of Materials. In instances where necessary work items are inadvertently left out in BOC Form, a bidder should make a written query to the Bids and Awards Committee so that the same shall be addressed in the Bid Bulletin which will be issued to all participating bidders.
4. All documents must be signed, and each and every page thereof must be initialed by the duly authorized representative(s) of the Bidder.
5. Unit Price of the Purchase Item shall include the following:
 - 5.1 Materials, fabrication and installation costs
 - 5.2 Overhead expenses such as office expenses, equipment, transportation allowances, and training costs (Premium on CMT, Bid Security, Performance Security, Surety for advance payment, Warranty bond)
 - 5.3 Contingencies, miscellaneous expenses and Contractor's Profit margin
6. It is the responsibility of the Bidder to check the official/total computation provided herein.

Submitted by: _____
(Name of Bidder / Company Name)

Prepared by: _____
(Company Representative / Signature (date printed below))

Address: _____

Telephone #: _____
Date: _____



Republic of the Philippines
SOCIAL SECURITY SYSTEM
 East Ave., Diliman, Quezon City

Project: **FRPH**
 Location: **2F Citymall Danac, Oliver St. Ext. cor. F. Rolato St., Poblacion, Danac City, Cebu**

BILL OF QUANTITIES

ITEM	DESCRIPTION	QTY	UNIT	UNIT COST	VAT (12%)	TOTAL COST
(A)	(B)	(C)	(D)	(E)	(F)	(G)
1	MODULAR OFFICE SYSTEM					
	1. Branch Head Workstation (BHW)					
a.	1 pc. Driveway Free-Standing Executive Table, 1800mm L x 750mm D x 750mm H w/ MDF Board Tabletop w/ Plastic Coated w/ Rotating Cover and 30mm Hx MDF Board Side Support in HPL Finish					
b.	1 pc. Side Return Table 1200mm L x 400mm D x 750mm H x 30mm Hx MDF Board Cambratop w/ Plastic Coated w/ Rotating Cover, Co. 18 Metal Steel in Powder Coated Finish Legs Support and Co. 22 Steel Meshy Panel in Powder Coated Finish	1.0	pc			
c.	Accessories					
1.	1 pc. Cable Chassis, 300mm W x 400mm D x 150mm H					
2.	1 pc. Desktop Tray, Wood Finish					
	2. Section Head Workstation (SHW 1)					
a.	Module Panels & Supports					
1.	3 pcs. Polaris Screen Panel, Two-Tone, 1200mm W x 1200mm H x 30mm Hx with Powder Coated Aluminum Panel Riseaway for Cable & Outlets					
2.	3 pcs. Polaris Screen Panel, Two-Tone, 800mm W x 1200mm H x 30mm Hx with Powder Coated Aluminum Panel Riseaway for Cable & Outlets					
3.	3 pcs. Polaris Screen Panel, Two-Tone, 400mm W x 1200mm H x 30mm Hx with Powder Coated Aluminum Panel Riseaway for Cable & Outlets					
4.	3 pcs. Polaris Screen Panel, Monotone, 1800mm W x 750mm H x 30mm Hx with Powder Coated Aluminum Panel Riseaway for Cable & Outlets					
5.	3 pcs. Polaris Screen Panel, Two-Tone, 800mm W x 900mm H x 30mm Hx with Powder Coated Aluminum Panel Riseaway for Cable & Outlets					
6.	3 pcs. Aluminum End Ties, 1200mm H	3.0	pc			
7.	3 pcs. Aluminum End Ties, 800mm H					
8.	3 pcs. Aluminum End Ties, 400mm H					
9.	3 pcs. Aluminum End Ties, 1800mm H					
10.	9 pcs. Corner Pad, 2-way, 1200mm H					
11.	3 pcs. Corner Pad, 2-way, 800mm H					
b.	Module Worktop					
1.	3 pcs. Rectangular Worktop, 1200mm L x 400mm W x 30mm Hx MDF Board in HPL Finish, w/ 2 pcs. Plastic Coated w/ Rotating Cover					
2.	3 pcs. Rectangular Worktop, 1200mm L x 400mm W x 30mm Hx MDF Board in HPL Finish, w/ 2 pcs. Plastic Coated w/ Rotating Cover					
c.	Accessories					
1.	3 pcs. Cable Chassis, 300mm W x 400mm D x 150mm H					
2.	3 pcs. Desktop Tray, Wood Finish					
	3. Section Head Workstation (SHW 2)					
a.	Module Panels & Supports					
1.	3 pcs. Polaris Screen Panel, Two-Tone, 1200mm W x 1200mm H x 30mm Hx with Powder Coated Aluminum Panel Riseaway for Cable & Outlets					
2.	3 pcs. Polaris Screen Panel, Two-Tone, 800mm W x 1200mm H x 30mm Hx with Powder Coated Aluminum Panel Riseaway for Cable & Outlets					
3.	3 pcs. Polaris Screen Panel, Two-Tone, 400mm W x 1200mm H x 30mm Hx with Powder Coated Aluminum Panel Riseaway for Cable & Outlets					
4.	3 pcs. Polaris Screen Panel, Two-Tone, 1800mm W x 900mm H x 30mm Hx with Powder Coated Aluminum Panel Riseaway for Cable & Outlets					
5.	3 pcs. Polaris Screen Panel, Two-Tone, 800mm W x 750mm H x 30mm Hx with Powder Coated Aluminum Panel Riseaway for Cable & Outlets					
6.	3 pcs. Aluminum End Ties, 1200mm H	3.0	pc			
7.	3 pcs. Aluminum End Ties, 750mm H					
8.	3 pcs. Aluminum End Ties, 300mm H					
9.	3 pcs. Aluminum End Ties, 1800mm H					
10.	9 pcs. Corner Pad, 2-way, 1200mm H					
11.	3 pcs. Corner Pad, 2-way, 800mm H					
b.	Module Worktop					
1.	3 pcs. Rectangular Worktop, 1200mm L x 400mm W x 30mm Hx MDF Board in HPL Finish, w/ 2 pcs. Plastic Coated w/ Rotating Cover					
2.	3 pcs. Rectangular Worktop, 1200mm L x 400mm W x 30mm Hx MDF Board in HPL Finish, w/ 2 pcs. Plastic Coated w/ Rotating Cover					
c.	Accessories					
1.	3 pcs. Cable Chassis, 300mm W x 400mm D x 150mm H					
2.	3 pcs. Desktop Tray, Wood Finish					
	4. Staff Workstation (SW 1)					
a.	Module Panels & Supports					
1.	4 pcs. Polaris Screen Panel, Monotone, 1200mm W x 750mm H x 30mm Hx with Powder Coated Aluminum Panel Riseaway for Cable & Outlets					
2.	12 pcs. Polaris Screen panel, Two-Tone, 800mm W x 900mm H x 30mm Hx with Powder Coated Aluminum Panel Riseaway for Cable & Outlets					
3.	12 pcs. Aluminum End Ties, 900mm H	12.0	pc			
4.	12 pcs. Aluminum End Ties, 1800mm H					
5.	12 pcs. Corner Pad, 2-way, 900mm H					
b.	Module Worktop					
1.	4 pcs. Rectangular Worktop, 1200mm L x 400mm W x 30mm Hx MDF Board in HPL Finish, w/ 2 pcs. Plastic Coated w/ Rotating Cover					
c.	Accessories					
1.	4 pcs. Desktop Tray, Wood Finish					

ITEM	DESCRIPTION				QTY	UNIT	UNIT COST	VRJ (12%)	RSBL COST
(A)	(B)				(C)	(D)	(E)	(F)	(G)
6. Staff Workstation (20%)									
a. Module Panels & Supports									
1.	2	pcs.	Panel: Screen Panel, Two-tone, 1300mm W x 1300mm H x 30mm Hk with Powder Coated Aluminium Panel Backing for Cables & Outlets						
2.	4	pcs.	Panel: Screen panel, Two-tone, 800mm W x 900mm H x 30mm Hk with Powder Coated Aluminium Panel Backing for Cables & Outlets						
3.	4	pcs.	Aluminium End Trim, 900mm H	20	sets				
4.	4	pcs.	Aluminium End Trim, 800mm H						
5.	4	pcs.	Corner Pad, 2-way, 1000mm H						
b. Module Worktop									
1.	2	pcs.	Rectangular Worktop, 1300mm L x 600mm W x 30mm Hk, MDP Based in HP, Finish w/ 1 (pc. Plastic Channel w/ Rotating Cover)						
c. Accessories									
1.	2	units	Embossed Tray - Head Pad(s)						
7. Computer Workstation (Per RAM)									
a. Free Standing Computer Table (FST), 1000mm L x 600mm D x 740mm Hk 30mm Hk MDP Based in HP, Finish, Post-Formed Front & Back Edges w/ Cast 18 Legs Support Powder-Coated Finish w/ Integrated Cable Management Channel w/ Plastic Channel w/ Rotating Cover									
1.0				1.0	unit				
7. ID Capture Workstation									
a. Module Panels & Supports									
1.	2	pcs.	Panel: Screen Panel, Two-tone, 1000mm W x 1400mm H x 30mm Hk with Powder Coated Aluminium Panel Backing for Cables & Outlets						
2.	2	pcs.	Corner Pad, 2-way, 1000mm H						
3.	2	pcs.	Aluminium End Trim, 1000mm H						
8. E-Center Station (750mm tabletop height)									
a. Module Panels & Supports									
1.	20	pcs.	Panel: Screen Panel, Two-tone, 800mm W x 1100mm H x 30mm Hk with Powder Coated Aluminium Panel Backing for Cables & Outlets						
2.	10	pcs.	Panel: Screen Panel, Two-tone, 750mm W x 1100mm H x 30mm Hk with Powder Coated Aluminium Panel Backing for Cables & Outlets						
3.	20	pcs.	Aluminium End Trim, 1100mm H						
4.	20	pcs.	Corner Pad, 2-way, 1100mm H						
b. Module Worktop									
1.	10	pcs.	Rectangular Worktop, 750mm L x 800mm W x 30mm Hk, MDP Based in HP, Finish w/ 1 (pc. Plastic Channel w/ Rotating Cover)						
c. Accessories									
1.	10	sets	CFD Holder						
2.	10	sets	Acrylic Plastic Divider						
3.	10	sets	Full-rod Covers for Support						
F. Desk & Tables									
a. Executive Conference Table (3-seater, Roof Slope w/ Wire Management) MDP Based in HP, Finish									
1.0				1.0	unit				
SUB-TOTAL - LOT 1 - MODULAR OFFICE SYSTEM									
7. Seating Furniture									
7.01 - Executive Chair, 2-piece, High-Back									
1.00				1.00	unit				
7.02 - Supervisor's Chair, 1-piece, Mid-Back w/ Armrest									
8.00				8.00	units				
7.03 - Non-Supervisor's Chair/Staff Chair, 1-piece, Low-Back w/ Armrest									
19.00				19.00	units				
7.04 - Teller's High Chair w/ Backing, 2-piece, Mid-Back									
1.00				1.00	unit				
7.05 - Guard Chair 1, 2-piece, Mid-Back, Cantilever Type (for Resilience) w/ Armrest									
2.00				2.00	units				
7.06 - Guard Chair 2, 2-piece, Mid-Back, Ball Base w/ Armrest w/ Foam Cushion									
12.00				12.00	units				
7.07 - 4-Wheeler-Gang Chair, 200mm x 60mm Rollers, Powder Coated Steel									
6.00				6.00	units				
SUB-TOTAL - LOT 2 - SEATING FURNITURE									
8. Contract Furniture									
1. Transaction Counter / Generalist Counter (20%)									
a. Module Panels & Supports									
1.	8	pcs.	Side Support Panel, 800mm W x 1000mm H x 30mm Hk, MDP Based in HP, Finish						
2.	4	pcs.	Front Modesty Panel, 1400mm W x 700mm H x 30mm Hk, Marine Plywood w/ Horizontal Strips using 1/2" Hk MDP Based in HP, Finish						
3.	4	pcs.	Side Modesty Panel, 1000mm W x 700mm H x 30mm Hk, MDP Based in HP, Finish						
4.	8	pcs.	Side Support Panel, 600mm W x 700mm H x 30mm Hk, MDP Based in PVC Film Finish						
b. Module Worktop									
1.	4	pcs.	Rectangular Worktop, 1400mm L x 700mm W x 30mm Hk, w/ Synthetic Stone (Acrylic) w/ Plastic Channel w/ Rotating Cover						
2.	4	pcs.	Rectangular Worktop, 1000mm L x 600mm W x 30mm Hk, w/ Synthetic Stone (Acrylic) w/ Plastic Channel w/ Rotating Cover						
3.	4	pcs.	Undercounter Ledge, 800mm L x 200mm W x 20mm Hk, Marble Based in HP, Finish w/ Plastic Channel w/ Rotating Cover						
c. Accessories									
1.	4	units	4-Layer Bull-Ht Cover, 600mm W x 600mm D x 30mm Hk, MDP Based in HP, Finish						
2.	4	units	100mm W x 100mm H 88 Logo in Stainless Steel Sheet						
3.	4	units	Embossed Tray - Head Pad(s)						
2. Information Booth (Info)									
Drilled, 1800mm L x 1000mm W x 1100mm H x 11mm Hk, Marine Plywood Corcose w/ Bull-Ht Drawers									
1.0				1.0	unit				
3. News/Voting Counter (NVC)									
600mm W x 1800mm L x 1000mm H Rectangular Shaped Voting Counter made of MDP Based tabletop in HP, 80mm and 40mm powder-coated tubular seating leg									
1.0				1.0	unit				
4. Guard's Pod									
Drilled Guard Station in Marine Plywood Corcose, HP, Finish w/ Bull-Ht Drawers, Stainless Steel Sheet Lining & Embossed Logo									
1.0				1.0	unit				
5. Manager's Desk Cabinet (MDC)									
1800mm W x 600mm D x 740mm H 11mm Hk, Marine Plywood in PVC Film Finish or Approved Equal									
1.0				1.0	unit				
SUB-TOTAL - LOT 3 - CONTRACT FURNITURE									

ITEM	DESCRIPTION	QTY	UNIT	UNIT COST	VRU (12%)	NET COST	
(A)	(B)	(C)	(D)	(E)	(F)	(G)	
STEEL SHELVES, CABINETS & DRAWERS							
1	Open Steel Shelving (OS) - 48" x 24" x 8" H	10	units		-	-	
2	Lateral filing Cabinet - 48" x 24" x 8" H	10	units		-	-	
3	Mobile Pedestal Drawers 3-Drawers, 48" x 24" x 8" H	14.0	units		-	-	
SUB-TOTAL - LOT IV - STEEL SHELVES, CABINETS & DRAWERS							-
PERCENT CHARGES including Labor and Office Expenses							
GRAND TOTAL						-	

GENERAL CONDITIONS

- For uniformity and evaluation purposes, a Bidder shall adhere to the herein prescribed format of BOC, specifically to the formula for computation, given quantity and exclusive pay items. Any deviation from the format shall be a ground for disqualification of bid.
 - If an item is given for bid, indicate check (✓), zero (0) or free
 - If the item is not applicable, indicate (N/A)
- Each Bidder shall be provided with hard copy of the BOC Form (attached in the BID) and an electronic copy for faster and easier encoding. The hard copy shall serve as the Bidder's reference as to completeness of each item, quantity, formula, format, etc. in the BOC Form considering that the electronic copy is prone to alterations during encoding. Any discrepancy on the contents (quantity and the quantity and exclusive pay items) between the hard copy and electronic, the contents of the hard copy shall prevail.
- Bidder are not allowed to include any pay items that were not indicated in the form supplied. In instances where necessary work items are inadvertently left out in BOC Form, a Bidder should make a written query to the Bids and Awards Committee so that the same shall be addressed in the Bid Bulletin which will be issued to all participating bidders.
 - All documents must be signed, and each and every page thereof must be initialed by the duly authorized representative(s) of the Bidder.
 - Unit Price of the Purchase Item shall include the following:
 - Material, Subcontract and Installation costs
 - Overhead expenses such as office expenses, supervision, transportation allowances, and financing costs (Premium on Cash, Bid Security, Performance Security, Surety for advance payment, Warranty bond)
 - Contingencies, miscellaneous expenses and Contractor's Profit margin
 - It is the responsibility of the Bidder to check the aforementioned computerized provided format.

Submitted by: _____
(Name of Bidder / Company Name)

Prepared by: _____
(Company Representative - Signature over printed name)

Address: _____

Telephone #: _____
Date: _____



Republic of the Philippines
SOCIAL SECURITY SYSTEM
 East Ave., Diliman, Quezon City

Project: **FRER**
 Location: **SSS Iamboanga, NIDCO Building, Veterans Avenue, Iamboanga City**

BILL OF QUANTITIES

ITEM	DESCRIPTION			QTY	UNIT	UNIT COST	VAT (12%)	TOTAL COST
(A)	(B)			(C)	(D)	(E)	(F)	(G)
1	MODULAR OFFICE SYSTEM							
	1. Branch Head Workstation (BHW)							
a.	1	pc.	D-ringed Free-Standing Executive Table, 1800mm L x 750mm D x 750mm H in 30mm BS MDF Board (Tabletop w/ Plastic Grannnel w/ Rotating Cover and 30mm BS MDF Board Side Support in HP, Finish					
b.	1	pc.	Side Return Table 1200mm L x 400mm D x 750mm H x 30mm BS MDF Board Cambrilating w/ Plastic Grannnel w/ Rotating Cover, Co.18 Metal Steel in Powder Coated Finish Legs Support and Co.22 Steel Modesty Panel in Powder Coated Finish	1.0	pc.		-	-
c.	Accessories							
1.	1	pc.	Center Drawer, 300mm W x 400mm D x 100mm H					
2.	1	pc.	Desktop Tray, Head Rest					
	2. Division Head Workstation (DHW)							
a.	1	pc.	D-ringed Free-Standing Executive Table, 1800mm L x 750mm D x 750mm H in 30mm BS MDF Board (Tabletop w/ Plastic Grannnel w/ Rotating Cover and 30mm BS MDF Board Side Support in HP, Finish					
b.	1	pc.	Side Return Table 1200mm L x 400mm D x 750mm H x 30mm BS MDF Board Cambrilating w/ Plastic Grannnel w/ Rotating Cover, Co.18 Metal Steel in Powder Coated Finish Legs Support and Co.22 Steel Modesty Panel in Powder Coated Finish	1.0	pc.		-	-
c.	Accessories							
1.	1	pc.	Center Drawer, 300mm W x 400mm D x 100mm H					
2.	1	pc.	Desktop Tray, Head Rest					
	3. Chief Legal Head Workstation (CLHW)							
a.	1	pc.	D-ringed Free-Standing Executive Table, 1800mm L x 750mm D x 750mm H in 30mm BS MDF Board (Tabletop w/ Plastic Grannnel w/ Rotating Cover and 30mm BS MDF Board Side Support in HP, Finish					
b.	1	pc.	Side Return Table 1200mm L x 400mm D x 750mm H x 30mm BS MDF Board Cambrilating w/ Plastic Grannnel w/ Rotating Cover, Co.18 Metal Steel in Powder Coated Finish Legs Support and Co.22 Steel Modesty Panel in Powder Coated Finish	1.0	pc.		-	-
c.	Accessories							
1.	1	pc.	Center Drawer, 300mm W x 400mm D x 100mm H					
2.	1	pc.	Desktop Tray, Head Rest					
	4. Assistant Branch Head Workstation (ABHW)							
a.	Modesty Panels & Supports							
1.	1	pc.	Polaris Screen panel, Two-tone, 1200mm W x 1800mm H x 30mm BS with Powder Coated Aluminum Panel Backing for Cable & Outlets and Counter Glass					
2.	1	pc.	Polaris Screen panel, Two-tone, 700mm W x 1800mm H x 30mm BS with Powder Coated Aluminum Panel Backing for Cable & Outlets and Counter Glass					
3.	1	pc.	Polaris Screen Panel, Two-tone, 400mm W x 1800mm H x 30mm BS with Powder Coated Aluminum Panel Backing for Cable & Outlets and Counter Glass					
4.	2	pc.	Aluminum End Ties, 1800mm H	1.0	pc.		-	-
5.	1	pc.	Corner Pad, 2-way, 1800mm H					
b.	Modesty Worktop							
1.	1	pc.	Rectangular Worktop, 1800mm L x 400mm W x 30mm BS MDF Board in HP, Finish, w/ 2pcs. Plastic Grannnel w/ Rotating Cover					
2.	1	pc.	Rectangular Worktop, 1200mm L x 400mm W x 30mm BS MDF Board in HP, Finish, w/ 2pcs. Plastic Grannnel w/ Rotating Cover					
3.	1	pc.	Head Modesty Panel, 1800mm W x 400mm H x 20mm BS MDF Board in HP, Finish					
c.	Accessories							
1.	1	unit	Center Drawer, 300mm W x 400mm D x 100mm H					
2.	1	unit	Desktop Tray, Head Rest					
	5. Division Head Office - Section Head Workstation (DHW-O)							
a.	Modesty Panels & Supports							
1.	3	pc.	Polaris Screen Panel, Two-tone, 1200mm W x 1800mm H x 30mm BS with Powder Coated Aluminum Panel Backing for Cable & Outlets					
2.	3	pc.	Polaris Screen Panel, Two-tone, 800mm W x 1800mm H x 30mm BS with Powder Coated Aluminum Panel Backing for Cable & Outlets					
3.	3	pc.	Polaris Screen Panel, Two-tone, 400mm W x 1800mm H x 30mm BS with Powder Coated Aluminum Panel Backing for Cable & Outlets					
4.	3	pc.	Polaris Screen Panel, Two-tone, 1800mm W x 700mm H x 30mm BS with Powder Coated Aluminum Panel Backing for Cable & Outlets					
5.	3	pc.	Polaris Screen Panel, Two-tone, 800mm W x 900mm H x 30mm BS with Powder Coated Aluminum Panel Backing for Cable & Outlets					
6.	3	pc.	Aluminum End Ties, 1800mm H	3.0	pc.		-	-
7.	3	pc.	Aluminum End Ties, 900mm H					
8.	3	pc.	Aluminum End Ties, 400mm H					
9.	3	pc.	Aluminum End Ties, 1800mm H					
10.	4	pc.	Corner Pad, 2-way, 1800mm H					
11.	3	pc.	Corner Pad, 2-way, 900mm H					
b.	Modesty Worktop							
1.	3	pc.	Rectangular Worktop, 1800mm L x 400mm W x 30mm BS MDF Board in HP, Finish, w/ 2pcs. Plastic Grannnel w/ Rotating Cover					
2.	3	pc.	Rectangular Worktop, 1200mm L x 400mm W x 30mm BS MDF Board in HP, Finish, w/ 2pcs. Plastic Grannnel w/ Rotating Cover					
c.	Accessories							
1.	3	units	Center Drawer, 300mm W x 400mm D x 100mm H					
2.	3	units	Desktop Tray, Head Rest					

ITEM	DESCRIPTION				QTY	UNIT	UNIT COST	VRJ (12%)	ROBL COST
(A)	(B)				(C)	(D)	(E)	(F)	(G)
	4. Staff Workstation (SW-1)								
	a. Module Panels & Supports								
1.	27	pcs.	Polaris Screen Panel, Monochrome, 1000mm W x 700mm H x 30mm TH with Powder Coated Aluminum Panel Backing for Cables & Outlets						
2.	28	pcs.	Polaris Screen Panel, Two-tone, 800mm W x 900mm H x 30mm TH with Powder Coated Aluminum Panel Backing for Cables & Outlets						
3.	29	pcs.	Aluminum End Trim, 900mm H	47.0	unit				
4.	30	pcs.	Aluminum End Trim, 1800mm H						
5.	31	pcs.	Corner Post, 2-way, 900mm H						
	b. Module Worktop								
1.	27	pcs.	Rectangular Worktop, 1000mm L x 600mm W x 30mm TH, MDF Based in HP, Finish w/ 1 Spec. Plastic Grained w/ Rolling Cover						
	c. Accessories								
1.	27	units	Enclosed Tray, Head Rest						
	7. B-Counter Station (750mm tabletop height)								
	a. Module Panels & Supports								
1.	32	pcs.	Polaris Screen Panel, Two-tone, 800mm W x 1100mm H x 30mm TH with Powder Coated Aluminum Panel Backing for Cables & Outlets						
2.	33	pcs.	Polaris Screen Panel, Two-tone, 700mm W x 1100mm H x 30mm TH with Powder Coated Aluminum Panel Backing for Cables & Outlets						
3.	34	pcs.	Aluminum End Trim, 1100mm H						
4.	35	pcs.	Corner Post, 2-way, 1100mm H	10.0	unit				
	b. Module Worktop								
1.	32	pcs.	Rectangular Worktop, 700mm L x 800mm W x 30mm TH, MDF Based in HP, Finish w/ 1 Spec. Plastic Grained w/ Rolling Cover						
	c. Accessories								
1.	10	units	CPU Holder						
2.	10	units	Acrylic Plastic Divider						
3.	10	units	Full-rod Closure for Cabinet						
	8. Computer Workstation (For SMD)								
	a. Free-Standing Computer Table (FST), 1000mm L x 600mm D x 750mm H, MDF Based in HP, Finish, Post-Tensioned Panel & Back Edges w/ Casters Legs Support Powder Coated Finish w/ Integrated Cable Management Channel w/ Plastic Grained w/ Rolling Cover				1.0	unit			
	9. ID Capture Workstation								
	a. Module Panels & Supports								
1.	7	pcs.	Polaris Screen Panel, Two-tone, 1000mm W x 1800mm H x 30mm TH with Powder Coated Aluminum Panel Backing for Cables & Outlets	1.0	unit				
2.	3	pcs.	Corner Post, 2-way, 1800mm H						
3.	2	pcs.	Aluminum End Trim, 1800mm H						
	10. Desks & Tables								
	a. Free-Standing Mobile Table (FT) - 800mm L x 600mm D x 750mm H, MDF Based in HP, Finish w/ Plastic Grained w/ Rolling Cover				1.0	unit			
	b. Executive Conference Table (Executive, Beak Design w/ Wire Management) MDF Based in HP, Finish				1.0	unit			
	c. Set of 4 - Module Seating Tables (600mm W x 1000mm L) supported by 40mm powder-coated tubular metal legs and casters				1.0	unit			
	d. Round Conference Table, 700mm dia, MDF Based in HP, Finish				1.0	unit			
	SUB-TOTAL - LCP 1 - MODULAR OFFICE SYSTEM								
	11. Seating Furniture								
1.	21	units	Executive Chair, 2-piece, High Back	250	unit				
2.	22	units	Supervisor's Chair, 1-piece, Mid Back w/ Armrest	20.00	unit				
3.	23	units	Non-Supervisor's Chair/Staff Chair, 1-piece, Low Back w/ Armrest	87.00	unit				
4.	24	units	Teller's High Chair w/ Backing, 2-piece, Mid Back	1.00	unit				
5.	25	units	Guard Chair 1, 2-piece, Mid Back, Curved Top (for Reception) w/ Armrest	6.00	unit				
6.	26	units	Guard Chair 2, 2-piece, Mid Back w/ Armrest, w/ Foam Cushion	29.00	unit				
7.	27	units	4-Wheeler Carry Chair, 200mm x 600mm, Powder Coated Steel	20.0	unit				
	SUB-TOTAL - LCP 2 - SEATING FURNITURE								
	12. Contract Furniture								
	1. Transaction Counter / General Counter (200)								
	a. Module Panels & Supports								
1.	12	pcs.	Side Support Panel, 800mm W x 1200mm H x 30mm TH, MDF Based in HP, Finish						
2.	4	pcs.	Front Modesty Panel, 1400mm W x 700mm H x 30mm TH, Marine Plywood w/ Horizontal Slats using 1/2" TH, MDF Based in HP, Finish						
3.	4	pcs.	Side Modesty Panel, 1000mm W x 700mm H x 30mm TH, MDF Based in HP, Finish						
4.	12	pcs.	Side Support Panel, 600mm W x 700mm H x 30mm TH, MDF Based in PVC Film Finish						
	b. Module Worktop								
1.	4	pcs.	Rectangular Worktop, 1400mm L x 180mm W x 30mm TH, w/ Synthetic Stone (Acrylic) w/ Plastic Grained w/ Rolling Cover	4.0	unit				
2.	4	pcs.	Rectangular Worktop, 1000mm L x 600mm W x 30mm TH, w/ Synthetic Stone (Acrylic) w/ Plastic Grained w/ Rolling Cover						
3.	4	pcs.	Undercounter Ledge, 800mm L x 200mm W x 20mm TH, Marble Based in HP, Finish w/ Plastic Grained w/ Rolling Cover						
	c. Accessories								
1.	4	units	4-Legs Bull-Horn Closure, 400mm W x 400mm D x 30mm TH, MDF Based in HP, Finish						
2.	4	units	100mm W x 100mm H 800 Logo in Stainless Steel Sheet						
3.	4	units	Enclosed Tray, Head Rest						
	2. Information Booth (Info)								
	Unkipped, 1800mm L x 1000mm W x 1100mm H x 10mm TH, Marine Plywood Cabinet w/ Bull-Horn Closure				1.0	unit			
	3. Home Wiring Counter (HWC)								
	600mm W x 1800mm L x 1000mm H Rectangular Shaped Wiring Counter made of MDF Based Tabletop in HP, Finish and 40mm powder-coated tubular metal leg				1.0	unit			
	4. Guard's Pad								
	Unkipped Guard Station in Marine Plywood Cabinet, HP, Finish w/ Bull-Horn Closure, Stainless Steel Seel Slating & Enclosed Logo				4.0	unit			
	5. Message's Book Cabinet (MBC)								
	1800mm W x 600mm D x 750mm H 10mm TH, Marine Plywood in PVC Film Finish or Approved Equal				1.0	unit			
	SUB-TOTAL - LCP 3 - CONTRACT FURNITURE								

ITEM	DESCRIPTION	QTY	UNIT	UNIT COST	VAT (12%)	TOTAL COST
(A)	(B)	(C)	(D)	(E)	(F)	(G)
iv. ITEM DETAILS, QUANTITIES & UNITS						
	1. Open Steel Barrows (OSB) 40kgm, 60x38	14.0	units		-	-
	2. Lateral Piling Cabinet 4-Drawers	14.0	units		-	-
	3. Mobile Protected Drawers 3-Drawers, 600mm W x 360mm D x 660mm H	10.0	units		-	-
	TOTAL QUANTITY - ITEM DETAILS, QUANTITIES & UNITS					
v. PERCENT CHARGES including labor and Other Expenses						
GRAND TOTAL						-

GENERAL CONDITIONS

- For uniformity and evaluation purposes, a bidder shall adhere to the herein prescribed format of BOC, specifically in the formula for computation, given quantity and include pay items. Any deviation from the format shall be a ground for disqualification of bid.
 - Fill up all required items/field in the BOC. Failure to indicate any of the following shall mean outright disqualification since bid is considered nonresponsive:
 - * If item is given for free, indicate dash (-), zero (0) or free
 - * If the item is not applicable, indicate N/A
- Each bidder shall be provided with hard copy of the BOC Form (attached in the PEO) and an electronic copy for later and easier encoding. The hard copy shall serve as the bidder's reference as to completeness of work items, quantity, formula, format, etc. in the BOC Form considering that the electronic copy is prone to alterations during encoding. Any discrepancy on the contents (quantity and the quantity and include pay items) between the hard copy and electronic, the contents of the hard copy shall prevail.
- Bidder are not allowed to include any pay items that were not included in the form supplied BOC of Quantities. In instances where necessary work items are inadvertently left out in BOC Form, a bidder should make a written query to the Bids and Awards Committee so that the same shall be addressed in the Bid Bulletin which will be issued to all participating bidders.
- All documents must be signed, and each and every page thereof must be initialed by the duly authorized representative(s) of the Bidder.
 - Unit Price of the Purchase Item shall include the following:
 - Materials, fabrication and installation costs
 - Overhead expenses such as office expenses, supervision, transportation allowances, and training costs (Premium on CMI, Bid Security, Performance Security, Surety for advance payment, Warranty bond)
 - Contingencies, miscellaneous expenses and Contractor's Profit margin
- It is the responsibility of the Bidder to check the differential computation provided herein.

Submitted by: _____
 (Name of Bidder / Company Name)

Prepared by: _____
 (Company Representative - Signature over printed name)

Address: _____

Telephone #: _____

Date: _____



Project: **FRER**
 Location: **TOPBRANDS building, Road Street, Poblacion, Bago City, Negros Occidental**

BILL OF QUANTITIES

ITEM	DESCRIPTION			QTY	UNIT	UNIT COST	VAT (12%)	TOTAL COST
(A)	(B)			(C)	(D)	(E)	(F)	(G)
1	MODULAR CANOPY SYSTEM							
	1. Branch Head Workstation (BHW)							
a.	1	pc.	Driveway Free-Standing Executive Table, 1800mm L x 750mm D x 750mm H in 30mm BS MDF Board/Tabling w/ Plastic Coarment w/ Rotating Cover and 30mm BS MDF Board Side Support in HP, Mesh					
b.	1	pc.	Side Return Table 1200mm L x 400mm D x 750mm H x 30mm BS MDF Board Cambrating w/ Plastic Coarment w/ Rotating Cover, Co.13 Mesh Steel in Powder Coated Mesh Legs Support and Co.13 Steel Meshery Panel in Powder Coated Mesh	1.0	pc.			
c.	Accessories							
1.	1	pc.	Center Drawer, 300mm W x 400mm D x 100mm H					
2.	1	pc.	Deployed Tray, Head Panel					
	2. Section Head Workstation (SHW) Swivel with additional panel							
a.	Module Panels & Supports							
1.	2	pc.	Polaris Screen Panel, Teal-tone, 1200mm W x 1200mm H x 30mm BS with Powder Coated Aluminum Panel Recessory for Cables & Outlets					
2.	2	pc.	Polaris Screen Panel, Teal-tone, 400mm W x 1200mm H x 30mm BS with Powder Coated Aluminum Panel Recessory for Cables & Outlets					
3.	2	pc.	Polaris Screen Panel, Teal-tone, 400mm W x 1200mm H x 30mm BS with Powder Coated Aluminum Panel Recessory for Cables & Outlets					
4.	2	pc.	Polaris Screen Panel, Almond-tone, 1800mm W x 900mm H x 30mm BS with Powder Coated Aluminum Panel Recessory for Cables & Outlets					
5.	2	pc.	Polaris Screen Panel, Teal-tone, 400mm W x 900mm H x 30mm BS with Powder Coated Aluminum Panel Recessory for Cables & Outlets					
6.	2	pc.	Polaris Screen Panel, Almond-tone, 400mm W x 1200mm H x 30mm BS with Powder Coated Aluminum Panel Recessory for Cables & Outlets	2.0	pc.			
7.	2	pc.	Polaris Screen Panel, Teal-tone, 750mm W x 1200mm H x 30mm BS with Powder Coated Aluminum Panel Recessory for Cables & Outlets					
8.	4	pc.	Aluminum End Ties, 1200mm H					
9.	2	pc.	Aluminum End Ties, 900mm H					
10.	4	pc.	Corner Pad, 3-way, 1200mm H					
11.	2	pc.	Corner Pad, 3-way, 900mm H					
b.	Module Worktop							
1.	2	pc.	Rectangular Worktop, 1800mm L x 400mm W x 30mm BS MDF Board in HP, Mesh, w/ 2pc. Plastic Coarment w/ Rotating Cover					
2.	2	pc.	Rectangular Worktop, 1000mm L x 400mm W x 30mm BS MDF Board in HP, Mesh, w/ 2pc. Plastic Coarment w/ Rotating Cover					
c.	Accessories							
1.	2	units	Center Drawer, 300mm W x 400mm D x 100mm H					
2.	2	units	Deployed Tray, Head Panel					
	3. Section Head Workstation (SHW) Swivel with additional panel							
a.	Module Panels & Supports							
1.	2	pc.	Polaris Screen Panel, Teal-tone, 1200mm W x 1200mm H x 30mm BS with Powder Coated Aluminum Panel Recessory for Cables & Outlets					
2.	2	pc.	Polaris Screen Panel, Teal-tone, 400mm W x 1200mm H x 30mm BS with Powder Coated Aluminum Panel Recessory for Cables & Outlets					
3.	4	pc.	Polaris Screen Panel, Teal-tone, 400mm W x 1200mm H x 30mm BS with Powder Coated Aluminum Panel Recessory for Cables & Outlets					
4.	4	pc.	Polaris Screen Panel, Almond-tone, 1800mm W x 900mm H x 30mm BS with Powder Coated Aluminum Panel Recessory for Cables & Outlets					
5.	4	pc.	Polaris Screen Panel, Teal-tone, 400mm W x 900mm H x 30mm BS with Powder Coated Aluminum Panel Recessory for Cables & Outlets					
6.	2	pc.	Polaris Screen Panel, Almond-tone, 400mm W x 1200mm H x 30mm BS with Powder Coated Aluminum Panel Recessory for Cables & Outlets	2.0	pc.			
7.	4	pc.	Polaris Screen Panel, Teal-tone, 750mm W x 1200mm H x 30mm BS with Powder Coated Aluminum Panel Recessory for Cables & Outlets					
8.	8	pc.	Aluminum End Ties, 1200mm H					
9.	4	pc.	Aluminum End Ties, 900mm H					
10.	4	pc.	Corner Pad, 3-way, 1200mm H					
11.	4	pc.	Corner Pad, 3-way, 900mm H					
b.	Module Worktop							
1.	4	pc.	Rectangular Worktop, 1800mm L x 400mm W x 30mm BS MDF Board in HP, Mesh, w/ 2pc. Plastic Coarment w/ Rotating Cover					
2.	4	pc.	Rectangular Worktop, 1000mm L x 400mm W x 30mm BS MDF Board in HP, Mesh, w/ 2pc. Plastic Coarment w/ Rotating Cover					
c.	Accessories							
1.	4	units	Center Drawer, 300mm W x 400mm D x 100mm H					
2.	4	units	Deployed Tray, Head Panel					
	4. Staff Workstation (SW-1)							
a.	Module Panels & Supports							
1.	2	pc.	Polaris Screen Panel, Almond-tone, 1200mm W x 900mm H x 30mm BS with Powder Coated Aluminum Panel Recessory for Cables & Outlets					
2.	4	pc.	Polaris Screen Panel, Teal-tone, 400mm W x 900mm H x 30mm BS with Powder Coated Aluminum Panel Recessory for Cables & Outlets					
3.	4	pc.	Aluminum End Ties, 900mm H					
4.	4	pc.	Corner Pad, 3-way, 900mm H					
b.	Module Worktop							
1.	2	pc.	Rectangular Worktop, 1200mm L x 400mm W x 30mm BS MDF Board in HP, Mesh, w/ 2pc. Plastic Coarment w/ Rotating Cover	2.0	pc.			
c.	Accessories							
1.	2	units	Deployed Tray, Head Panel					

ITEM	DESCRIPTION	QTY	UNIT	UNIT COST	VRJ (12%)	FORMAL COST
(A)	(B)	(C)	(D)	(E)	(F)	(G)
6. Draft Workstation (2P/3 seater)						
a. Module Panels & Supports						
1.	4	pcs.	Polaris Screen Panel, Two-tone, 1200mm W x 900mm H x 30mm Bx with Powder Coated Aluminium Panel Backing for Cables & Outlets			
2.	4	pcs.	Polaris Screen panel, Two-tone, 600mm W x 900mm H x 30mm Bx with Powder Coated Aluminium Panel Backing for Cables & Outlets			
3.	4	pcs.	Aluminium End Ties, 900mm H	20	sets	-
4.	2	pcs.	Corner Pad, 2-way, 900mm H			
5.	4	pcs.	Corner Pad, 2-way, 900mm H			
b. Module Worktop						
1.	4	pcs.	Rectangular Worktop, 1200mm L x 600mm W x 30mm Bx, MDF Board in HPL, Finish w/ 2yrs. Plastic Guarantee w/ Rotating Cover			
c. Accessories						
1.	4	units	Desktop Tray, Head Pad(s)			
7. Draft Workstation (2P/3 seater)						
a. Module Panels & Supports						
1.	4	pcs.	Polaris Screen Panel, Two-tone, 1200mm W x 900mm H x 30mm Bx with Powder Coated Aluminium Panel Backing for Cables & Outlets			
2.	8	pcs.	Polaris Screen panel, Two-tone, 600mm W x 900mm H x 30mm Bx with Powder Coated Aluminium Panel Backing for Cables & Outlets			
3.	8	pcs.	Aluminium End Ties, 900mm H	20	sets	-
4.	4	pcs.	Corner Pad, 2-way, 900mm H			
5.	4	pcs.	Corner Pad, 2-way, 900mm H			
b. Module Worktop						
1.	4	pcs.	Rectangular Worktop, 1200mm L x 600mm W x 30mm Bx, MDF Board in HPL, Finish w/ 2yrs. Plastic Guarantee w/ Rotating Cover			
c. Accessories						
1.	4	units	Desktop Tray, Head Pad(s)			
7. ID Capture Workstation						
a. Module Panels & Supports						
1.	8	pcs.	Polaris Screen Panel, Two-tone, 1000mm W x 1800mm H x 30mm Bx with Powder Coated Aluminium Panel Backing for Cables & Outlets	1.0	unit	-
2.	2	pcs.	Corner Pad, 2-way, 1800mm H			
3.	2	pcs.	Aluminium End Ties, 1800mm H			
8. 8-Counter Station (2 Workstations height)						
a. Module Panels & Supports						
1.	40	pcs.	Polaris Screen Panel, Two-tone, 600mm W x 1100mm H x 30mm Bx with Powder Coated Aluminium Panel Backing for Cables & Outlets			
2.	20	pcs.	Polaris Screen Panel, Two-tone, 900mm W x 1100mm H x 30mm Bx with Powder Coated Aluminium Panel Backing for Cables & Outlets			
3.	40	pcs.	Aluminium End Ties, 1100mm H	10.0	sets	-
4.	40	pcs.	Corner Pad, 2-way, 1100mm H			
b. Module Worktop						
1.	20	pcs.	Rectangular Worktop, 700mm L x 600mm W x 30mm Bx, MDF Board in HPL, Finish w/ 1yrs. Plastic Guarantee w/ Rotating Cover			
c. Accessories						
1.	20	sets	CPD Holder			
2.	20	sets	Acrylic Plastic Divider			
3.	20	sets	Pushout Cover for Scanner			
F. Desks & Tables						
1.	1	unit	Executive Conference Table (3-seater, Solid Edge w/ Wire Management) MDF Board in HPL, Finish	1.0	unit	-
SUB-TOTAL - LCP I - MODULAR OFFICE SYSTEM						
II. SEATED FURNITURE						
1.	21	unit	Executive Chair, 2-piece, High Back	1.20	unit	-
2.	21	unit	Supervisor's Chair, 1-piece, Mid Back w/ Armrest	4.00	unit	-
3.	21	unit	Non-Supervisor's Chair/Staff Chair, 1-piece, Low Back w/ Armrest	10.00	unit	-
4.	21	unit	Teller's High Chair w/ Footing, 2-piece, Mid Back	1.00	unit	-
5.	21	unit	Round Chair 1, 2-piece, Mid Back, Curved Top (for Reception) w/ Armrest	2.00	unit	-
6.	21	unit	Round Chair 2, 2-piece, Mid Back w/ Armrest, w/ Foam Cushion	14.00	unit	-
7.	21	unit	4-Drawer Cart Chair, 210mm x 60mm x 60mm, Powder Coated Steel	14.00	unit	-
SUB-TOTAL - LCP II - SEATED FURNITURE						
III. CONTRACT FURNITURE						
1. Reception Counter / Service/Staff Counter (2P/3)						
a. Module Panels & Supports						
1.	8	pcs.	Side Support Panel, 600mm W x 1200mm H x 30mm Bx, MDF Board in HPL, Finish			
2.	4	pcs.	Front Module Panel, 1400mm W x 700mm H x 30mm Bx, Marine Plywood w/ Horizontal Slats using 1/2" Bx, MDF Board in HPL, Finish			
3.	4	pcs.	Side Module Panel, 1000mm W x 700mm H x 30mm Bx, MDF Board in HPL, Finish			
4.	8	pcs.	Side Support Panel, 600mm W x 700mm H x 30mm Bx, MDF Board in PVC Film Finish			
b. Module Worktop						
1.	4	pcs.	Rectangular Worktop, 1400mm L x 180mm W x 30mm Bx, w/ Synthetic Stone (Acrylic) w/ Plastic Guarantee w/ Rotating Cover	4.0	sets	-
2.	4	pcs.	Rectangular Worktop, 1000mm L x 600mm W x 30mm Bx, w/ Synthetic Stone (Acrylic) w/ Plastic Guarantee w/ Rotating Cover			
3.	4	pcs.	Undercounter Ledge, 800mm L x 100mm W x 30mm Bx, Marble Board in HPL, Finish w/ Plastic Guarantee w/ Rotating Cover			
c. Accessories						
1.	4	units	4-Layer Built-in Drawer, 400mm W x 400mm D x 30mm Bx, MDF Board in HPL, Finish			
2.	4	units	120mm W x 100mm H 600 Logo in Stainless Steel Sheet			
3.	4	units	Desktop Tray, Head Pad(s)			
2. Information Booth (Info)						
Dropped, 1800mm L x 1000mm W x 1100mm H x 30mm Bx, Marine Plywood Corcose w/ Built-in Drawers						
1.0	1	unit				
3. Home Working Counter (HWC)						
600mm W x 1800mm L x 1500mm H Rectangular Shaped Working Counter made of MDF board, Slatscap in HPL, Side and 60cm-powdercoated tubular desk leg						
2.0	1	unit				

ITEM	DESCRIPTION	QTY	UNIT	UNIT COST	VAT (12%)	NET COST
(A)	(B)	(C)	(D)	(E)	(F)	(G)
	A. Guard's Post Drillings Guard Station to include Physical Closure, HPI Wash w/ Safety Covers, Stainless Steel Steel Siding & Reinforced Legs	20	units		-	-
	B. Manager's Desk Cabinet (MDC) 1800mm W x 600mm D x 750mm H 1100mm H to include Physical in PVC Film Wash or Approved Equal	10	unit		-	-
SUB-TOTAL - LOT III - CONTRACT FURNITURE						
IV						
ITRE, DRIVES, CABINETS & DRAWERS						
	1. Open Steel Shelves (OSS) 400mm, 2x 11	25.0	units		-	-
	2. Lateral filing Cabinet, 400mm	4.0	units		-	-
	3. Mobile Protected Drawers 2-Drawers, 400mm W x 600mm D x 600mm H	15.0	units		-	-
SUB-TOTAL - LOT IV - ITRE, DRIVES, CABINETS & DRAWERS						
V						
PERCENT CHARGES including Labor and Other Expenses						
GRAND TOTAL						-

GENERAL CONDITIONS

- For uniformity and evaluation purposes, a Bidder shall adhere to the herein prescribed format of BOD, specifically to the formula for computation, given quantity and inclusive pay items. Any deviation from the format shall be a ground for disqualification of Bids.
 - Fill up all required items/field in the BOD. Failure to indicate any of the following shall mean outright disqualification shall not be considered non-responsive:
 - * If item is given for free, indicate dash (-), zero (0) or free
 - * If the item is not applicable, indicate N/A
- Each bidder shall be provided with hard copy of the BOD Form (attached in the PSC) and an electronic copy for bids and e-bids encoding. The hard copy shall serve as the bidder's reference as to completeness of each item, quantity, formula, format, etc. in the BOD Form considering that the electronic copy is prone to alterations during encoding. Any discrepancy on the contents (quantity or the quantity and inclusive pay items) between the hard copy and electronic, the contents of the hard copy shall prevail.
- Bidder are not allowed to include any pay items that were not indicated in the form supplied Bill of Quantities. In instances where necessary work items are inadvertently left out in BOD Form, a Bidder should make a written query to the Bids and Awards Committee so that the same shall be addressed in the Bid Subject which will be issued to all participating bidders.
- All documents must be signed, and each and every page thereof must be initialed by the duly authorized representative/s of the Bidder.
 - Unit Price of the Furniture item shall include the following:
 - Materials, fabrication and installation costs
 - Overhead expenses such as office expenses, supervision, transportation allowances, and training costs (Premium on CAR, Bid Security, Performance Security, Surety for advance payment), Warranty bond)
 - Contingencies, miscellaneous expenses and Contractor's Profit margin
- It is the responsibility of the Bidder to check the aforementioned computer provided items.

Submitted by: _____
 (Name of Bidder / Company Name)

Prepared by: _____
 (Company Representative - Signature over printed name)

Address: _____

Telephone #: _____

Date: _____



Republic of the Philippines
SOCIAL SECURITY SYSTEM
 East Ave., Diliman, Quezon City

Project: **SEPLY, DELIVERY AND INSTALLATION OF MODULAR OFFICE SYSTEM AND FURNITURE FOR VARIOUS SSS BRANCH OFFICES**
 Location: **SSS Sagay, GF Square and Clades Bldg., National Highway, Old Sagay Road, Sagay City, Negros Occidental**

BILL OF QUANTITIES

ITEM	DESCRIPTION	QTY	UNIT	UNIT COST	VAJ (13%)	TOTAL COST
(A)	(B)	(C)	(D)	(E)	(F)	(G)
1	MODULAR OFFICE SYSTEM					
	1. Branch Head Workstation (24H)					
	a. Drivaplex Free-Standing Executive Table, 1800mm L x 750mm D x 750mm H in 30mm thick MDF Board (tabletop w/ Plastic Chrommel w/ Rotating Cover and 30mm thick MDF Board Side Support in HPL Finish)					
	b. Side Return Table 1200mm L x 600mm D x 750mm H in 30mm thick MDF Board (Chrommel w/ Plastic Chrommel w/ Rotating Cover, Double Metal Sheet in Powder Coated Finish Legs Support and Double Sheet Melamine Panel in Powder Coated Finish)	1.0	ml		-	-
	c. Accessories					
	1. Center Drawer, 360mm W x 400mm D x 100mm H					
	2. Embossed Tray, Wood Plastic					
	2. Section Head Workstation (24H-1)					
	a. Module Panels & Supports					
	1. Polaris Screen Panel, Teal-tone, 1300mm W x 1300mm H x 30mm thick with Powder Coated Aluminum Panel Backery for Cable & Outlets					
	2. Polaris Screen Panel, Teal-tone, 800mm W x 1300mm H x 30mm thick with Powder Coated Aluminum Panel Backery for Cable & Outlets					
	3. Polaris Screen Panel, Teal-tone, 600mm W x 1300mm H x 30mm thick with Powder Coated Aluminum Panel Backery for Cable & Outlets					
	4. Polaris Screen Panel, Marablon, 1000mm W x 700mm H x 30mm thick with Powder Coated Aluminum Panel Backery for Cable & Outlets					
	5. Polaris Screen Panel, Teal-tone, 800mm W x 900mm H x 30mm thick with Powder Coated Aluminum Panel Backery for Cable & Outlets					
	6. Aluminum End Ties, 1000mm H	4.0	mls		-	-
	7. Aluminum End Ties, 900mm H					
	8. Aluminum End Ties, 600mm H					
	9. Aluminum End Ties, 300mm H					
	10. Corner Pad, 3-way, 1000mm H					
	11. Corner Pad, 3-way, 900mm H					
	b. Module Worktop					
	1. Rectangular Worktop, 1000mm L x 600mm W x 30mm thick MDF Board in HPL Finish, w/ 2 (two) Plastic Chrommel w/ Rotating Cover					
	2. Rectangular Worktop, 1200mm L x 600mm W x 30mm thick MDF Board in HPL Finish, w/ 2 (two) Plastic Chrommel w/ Rotating Cover					
	c. Accessories					
	1. Center Drawer, 360mm W x 400mm D x 100mm H					
	2. Embossed Tray, Wood Plastic					
	3. Section Head Workstation (24H-2)					
	a. Module Panels & Supports					
	1. Polaris Screen Panel, Teal-tone, 1300mm W x 1300mm H x 30mm thick with Powder Coated Aluminum Panel Backery for Cable & Outlets					
	2. Polaris Screen Panel, Teal-tone, 800mm W x 1300mm H x 30mm thick with Powder Coated Aluminum Panel Backery for Cable & Outlets					
	3. Polaris Screen Panel, Teal-tone, 600mm W x 1300mm H x 30mm thick with Powder Coated Aluminum Panel Backery for Cable & Outlets					
	4. Polaris Screen Panel, Teal-tone, 1100mm W x 1300mm H x 30mm thick with Powder Coated Aluminum Panel Backery for Cable & Outlets					
	5. Polaris Screen Panel, Marablon, 1000mm W x 700mm H x 30mm thick with Powder Coated Aluminum Panel Backery for Cable & Outlets					
	6. Polaris Screen Panel, Teal-tone, 800mm W x 900mm H x 30mm thick with Powder Coated Aluminum Panel Backery for Cable & Outlets					
	7. Aluminum End Ties, 1000mm H	1.0	ml		-	-
	8. Aluminum End Ties, 900mm H					
	9. Aluminum End Ties, 600mm H					
	10. Corner Pad, 3-way, 1000mm H					
	11. Corner Pad, 3-way, 900mm H					
	b. Module Worktop					
	1. Rectangular Worktop, 1000mm L x 600mm W x 30mm thick MDF Board in HPL Finish, w/ 2 (two) Plastic Chrommel w/ Rotating Cover					
	2. Rectangular Worktop, 1200mm L x 600mm W x 30mm thick MDF Board in HPL Finish, w/ 2 (two) Plastic Chrommel w/ Rotating Cover					
	c. Accessories					
	1. Center Drawer, 360mm W x 400mm D x 100mm H					
	2. Embossed Tray, Wood Plastic					
	4. Section Head Workstation (24H-3 w/ extra panel)					
	a. Module Panels & Supports					
	1. Polaris Screen Panel, Teal-tone, 1300mm W x 1300mm H x 30mm thick with Powder Coated Aluminum Panel Backery for Cable & Outlets					
	2. Polaris Screen Panel, Teal-tone, 800mm W x 1300mm H x 30mm thick with Powder Coated Aluminum Panel Backery for Cable & Outlets					
	3. Polaris Screen Panel, Teal-tone, 600mm W x 1300mm H x 30mm thick with Powder Coated Aluminum Panel Backery for Cable & Outlets					
	4. Polaris Screen Panel, Teal-tone, 400mm W x 1300mm H x 30mm thick with Powder Coated Aluminum Panel Backery for Cable & Outlets					
	5. Polaris Screen Panel, Teal-tone, 700mm W x 1300mm H x 30mm thick with Powder Coated Aluminum Panel Backery for Cable & Outlets					
	6. Polaris Screen Panel, Marablon, 1000mm W x 700mm H x 30mm thick with Powder Coated Aluminum Panel Backery for Cable & Outlets					
	7. Polaris Screen Panel, Teal-tone, 800mm W x 900mm H x 30mm thick with Powder Coated Aluminum Panel Backery for Cable & Outlets					
	8. Aluminum End Ties, 1000mm H	1.0	ml		-	-
	9. Aluminum End Ties, 900mm H					

ITEM	DESCRIPTION			QTY	UNIT	UNIT COST	VM (13%)	FORM COST
(A)	(B)			(C)	(D)	(E)	(F)	(G)
	10.	1	pc.	Aluminum End Trim, 600mm H				
	11.	1	pc.	Corner Pad, 2-way, 1200mm H				
	12.	1	pc.	Corner Pad, 2-way, 1200mm H				
	13.	1	pc.	Corner Pad, 2-way, 600mm H				
	6. Module Worktop							
	1.	1	pc.	Rectangular Worktop, 1800mm L x 600mm W x 30mm H, MDP Based in HP, Finish w/ 2-ply, Plastic Grained w/ Rotating Cover				
	2.	1	pc.	Rectangular Worktop, 1200mm L x 600mm W x 30mm H, MDP Based in HP, Finish w/ 2-ply, Plastic Grained w/ Rotating Cover				
	7. Accessories							
	1.	1	unit	Center Drawer, 600mm W x 450mm D x 60mm H				
	2.	1	unit	Reinforced Tray, Hard Plastic				
	8. Staff Workstation (20' x 1')							
	9. Module Panels & Supports							
	1.	8	pc.	Polaris Screen Panel, Monitors, 1200mm W x 750mm H x 30mm H with Powder Coated Aluminum Panel Backing for Cable & Cables	60	unit		
	2.	14	pc.	Polaris Screen panel, Telephones, 600mm W x 900mm H x 30mm H with Powder Coated Aluminum Panel Backing for Cable & Cables				
	3.	14	pc.	Aluminum End Trim, 600mm H				
	4.	14	pc.	Aluminum End Trim, 1800mm H				
	5.	14	pc.	Corner Pad, 2-way, 600mm H				
	6. Module Worktop							
	1.	8	pc.	Rectangular Worktop, 1200mm L x 600mm W x 30mm H, MDP Based in HP, Finish w/ 2-ply, Plastic Grained w/ Rotating Cover				
	7. Accessories							
	1.	8	unit	Reinforced Tray, Hard Plastic				
	9. 8' Center Workstation							
	10. Module Panels & Supports							
	1.	20	pc.	Polaris Screen Panel, Telephones, 600mm W x 1180mm H x 30mm H with Powder Coated Aluminum Panel Backing for Cable & Cables	10.0	unit		
	2.	10	pc.	Polaris Screen Panel, Telephones, 750mm W x 1180mm H x 30mm H with Powder Coated Aluminum Panel Backing for Cable & Cables				
	3.	20	pc.	Aluminum End Trim, 1100mm H				
	4.	20	pc.	Corner Pad, 2-way, 1100mm H				
	6. Module Worktop							
	1.	10	pc.	Rectangular Worktop, 750mm L x 600mm W x 30mm H, MDP Based in HP, Finish w/ 1-ply, Plastic Grained w/ Rotating Cover				
	7. Accessories							
	1.	10	unit	CPU Holder				
	2.	10	unit	Acrylic Plastic Divider				
	3.	10	unit	Full-rod Cover for Slatcase				
	7. Desks & Tables							
	a. Set of 4 - Module Seating Tables (600mm W x 1800mm L) supported by 40mm powder-coated tubular metal legs and bases			1.0	unit			
	b. Round Conference Table, 600mm dia, MDP Based in HP, Finish			1.0	unit			
	SUB-TOTAL - LCP I - MODULAR OFFICE SYSTEMS							
	II - METAL FURNITURE							
	1. 21 - Reception Desk, 2-ply, High Back			1.00	unit			
	2. 22 - Reception's Chair, 1-ply, Mid Back w/ Armrest			4.00	unit			
	3. 23 - Reception's Chair/Staff Chair, 1-ply, Low Back w/ Armrest			10.00	unit			
	4. 24 - Teller's High Chair w/ Backing, 2-ply, Mid Back			5.00	unit			
	5. 25 - Guard Chair 1, 2-ply, Mid Back, Contoured Top (for Reception) w/ Armrest			3.00	unit			
	6. 26 - Guard Chair 2, 2-ply, Mid Back w/ Armrest, w/ Foam Cushion			10.00	unit			
	7. 27 - 4-Drawer Gang Chair, 250mm x 600mm x 60mm, Powder Coated Steel			14.0	unit			
	SUB-TOTAL - LCP II - METAL FURNITURE							
	III - CONTRACT FURNITURE							
	1. Reception Counter / Generalist Counter (20')							
	a. Module Panels & Supports							
	1.	8	pc.	Side Support Panel, 600mm W x 1200mm H x 30mm H, MDP Based in HP, Finish	40	unit		
	2.	4	pc.	Front Modesty Panel, 1400mm W x 750mm H x 30mm H, Marine Plywood w/ Horizontal Slats using 1/2" H, MDP Based in HP, Finish				
	3.	4	pc.	Side Modesty Panel, 1000mm W x 750mm H x 30mm H, MDP Based in HP, Finish				
	4.	8	pc.	Side Support Panel, 600mm W x 750mm H x 30mm H, MDP Based in PVC Film Finish				
	6. Module Worktop							
	1.	4	pc.	Rectangular Worktop, 1400mm L x 180mm W x 30mm H, w/ Synthetic Stone (Acrylic) w/ Plastic Grained w/ Rotating Cover				
	2.	4	pc.	Rectangular Worktop, 1000mm L x 600mm W x 30mm H, w/ Synthetic Stone (Acrylic) w/ Plastic Grained w/ Rotating Cover				
	3.	4	pc.	Undercounter Ledge, 600mm L x 200mm W x 20mm H, Marble Based in HP, Finish w/ Plastic Grained w/ Rotating Cover				
	7. Accessories							
	1.	4	unit	4-Drawer Built-in Drawer, 400mm W x 400mm D x 30mm H, MDP Based in HP, Finish				
	2.	4	unit	100mm W x 100mm H 30 Logo in Stainless Steel Sheet				
	3.	4	unit	Reinforced Tray, Hard Plastic				
	2. Information Booth (Info)			1.0	unit			
	3. Rem-Writing Counter (RWC)			3.0	unit			
	4. Guard's Pad			1.0	unit			
	5. Manager's Desk - Cabinet (MDC)			1.0	unit			
	SUB-TOTAL - LCP III - CONTRACT FURNITURE							

ITEM	DESCRIPTION	QTY	UNIT	UNIT COST	VAT (13%)	TOTAL COST
(A)	(B)	(C)	(D)	(E)	(F)	(G)
IV STEEL DRIVE, CABINET & DRAWER						
	1. Lateral Ring Cabinet, 4Drawers	1.0	units		-	-
	2. Mobile Parallel Drawers 3-Drawers, 400mm W x 1600mm D x 1600mm H	14.0	units		-	-
	SUB-TOTAL - LOT IV - STEEL DRIVE, CABINET & DRAWER					-
V PERCENT CHARGE including Labor and Office Expenses						
						-
GRAND TOTAL						-

GENERAL CONDITIONS

- For uniformity and evaluation purposes, a bidder shall adhere to the herein prescribed format of BOC, specifically in the format for computation, given quantity and include pay items. Any deviation from the format shall be a ground for disqualification of bid.
 - Fill up of required items/field in the BOC. Failure to indicate any of the following shall mean outright disqualification since bid is considered non-responsive
 - * If item is given for free, indicate dash (-), zero (0) or free
 - * If the item is not applicable, indicate N/A
- Each bidder shall be provided with hard copy of the BOC Form (attached in the PEO) and an electronic copy for table and e-bid encoding. The hard copy shall serve as the bidder's reference as to completeness of work items, quantity, formula, format, etc. in the BOC Form considering that the electronic copy is prone to alterations during encoding. Any discrepancy on the contents (quantity on the quantity and include pay items) between the hard copy and electronic, the contents of the hard copy shall prevail.
- Bidder are not allowed to include any pay items that were not indicated in the form supplied BOC of Quantities. In instances where necessary work items are inadvertently left out in BOC Form, a bidder should make a written query to the Bids and Awards Committee so that the same shall be addressed in the Bid Bulletin which will be issued to all participating bidders.
- All documents must be signed, and each and every page thereof must be initialed by the duly authorized representative/s of the Bidder.
 - Unit Price of the Purchase Item shall include the following:
 - Materials, fabrication and installation costs
 - Overhead expenses such as office expenses, supervision, transportation allowances, and bonding costs (Premium on CAR, Bid Security, Performance Security, Surety for advance payment), Warranty bond)
 - Contingencies, miscellaneous expenses and Contractor's Profit margin
 - It is the responsibility of the Bidder to check the differential computation provided herein.

Submitted by: _____
 (Name of Bidder / Company Name)

Prepared by: _____
 (Company Representative - Signature over printed name)

Address: _____

Telephone #: _____

Date: _____

Formula in the Computation of NFCC

NAME OF PROJECT

NAME OF COMPANY

NFCC = 15 (Current Assets – Current Liabilities) – Value of All Outstanding Works under On-going Contracts including Awarded Contracts yet to be started)

YEAR	CURRENT ASSETS	CURRENT LIABILITIES
TOTAL		

Value of Outstanding Works under On-going Contracts:

CONTRACT DESCRIPTION	TOTAL CONTRACT AMOUNT AT AWARD	PERCENTAGE OF PLANNED AND ACTUAL ACCOMPLISHMENT	ESTIMATED COMPLETION TIME
TOTAL			

Use additional sheet/s, if necessary

FORMULA:

$$15 \left(\frac{\text{Current Assets}}{\text{Current Assets}} - \frac{\text{Current Liabilities}}{\text{Current Liabilities}} \right) - \frac{\text{Total Outstanding Works}}{\text{Total Outstanding Works}} = \text{NFCC}$$

P _____ NFCC

Prepared and Submitted by:

Signature over Printed Name



(Name of Bank)

COMMITTED LINE OF CREDIT CERTIFICATE

Date: _____

Social Security System (SSS)
SSS Main Building, East Avenue
Diliman, Quezon City

CONTRACT PROJECT	:	_____
COMPANY/FIRM	:	_____
ADDRESS	:	_____
BANK/FINANCING	:	_____
INSTITUTION	:	_____
ADDRESS	:	_____
AMOUNT	:	_____

This is to certify that the above Bank/Financing Institution with business address indicated above, commits to provide the (Supplier/Distributor/Manufacturer/Contractor), if awarded the above-mentioned Contract, a credit line in the amount specified above which shall be exclusively used to finance the performance of the above-mentioned contract subject to our terms, conditions and requirements.

The credit line shall be available within fifteen (15) calendar days after receipt by the (Supplier/Distributor/Manufacturer/Contractor) of the Notice of Award and such line of credit shall be maintained until issuance of Certificate of Acceptance by the Social Security System.

This Certification is being issued in favor of said (Supplier/Distributor/Manufacturer/Contractor) in connection with the bidding requirement of (Name of Procuring Entity) for the above-mentioned Contract. We are aware that any false statements issued by us make us liable for perjury.

The committed line of credit cannot be terminated or cancelled without the prior written approval of Social Security System.

Name and Signature of Authorized Financing Institution Office

Office Designation

Concurred by:

Name & Signature of (Supplier/Distributor/Manufacturer/Contractor) Authorized Representative

Official Designation

SUBSCRIBED AND SWORN TO BEFORE ME this _____ day of _____ at _____
Philippines, Affiant exhibited to me his/her competent Evidence of Identity (as defines by the 2004
Rules on Notarial Practice _____ issued on _____ at _____, Philippines.

NOTARY PUBLIC

Doc No.	:	_____
Page No.	:	_____
Book No.	:	_____
Series of	:	_____

(Note: The amount committed should be machine validated in the Certificate itself)



FORM-05

STATEMENT OF ON-GOING GOVERNMENT AND PRIVATE CONTRACTS

NAME OF CONTRACT	DATE OF CONTRACT	CONTRACT DURATION	OWNER'S NAME, ADDRESS, CONTACT NUMBERS AND E-MAIL ADDRESS	KINDS OF GOODS	AMOUNT OF CONTRACT	VALUE OF OUTSTANDING CONTRACT	REMARKS (Indicate "With NDA" or "Without NDA")

NOTE: INCLUDING PROJECTS WITH NON-DISCLOSURE AGREEMENT.



FORM-06

**STATEMENT OF SINGLE LARGEST COMPLETED CONTRACT SIMILAR TO
THE PROJECT TO BE BID EQUIVALENT TO AT LEAST 50% OF THE ABC
WITH ATTACHED SUPPORTING DOCUMENTS (i.e. P.O/CONTRACTS)**

NAME OF CONTRACT	KINDS OF GOODS	AMOUNT OF CONTRACT	CONTACT PERSON, CONTACT NO., ADDRESS, AND EMAIL ADDRESS



Bid Securing Declaration Form

REPUBLIC OF THE PHILIPPINES) CITY OF
_____) S.S.

BID SECURING DECLARATION

Project Identification No.: [Insert number]

To: *[Insert name and address of the Procuring Entity]*

I/We, the undersigned, declare that:

1. I/We understand that, according to your conditions, bids must be supported by a Bid Security, which may be in the form of a Bid Securing Declaration.
2. I/We accept that: (a) I/we will be automatically disqualified from bidding for any procurement contract with any procuring entity for a period of two (2) years upon receipt of your Blacklisting Order; and, (b) I/we will pay the applicable fine provided under Section 6 of the Guidelines on the Use of Bid Securing Declaration, within fifteen (15) days from receipt of the written demand by the procuring entity for the commission of acts resulting to the enforcement of the bid securing declaration under Sections 23.1(b), 34.2, 40.1 and 69.1, except 69.1(f), of the IRR of RA No. 9184; without prejudice to other legal action the government may undertake.
3. I/We understand that this Bid Securing Declaration shall cease to be valid on the following circumstances:
 - a. Upon expiration of the bid validity period, or any extension thereof pursuant to your request;
 - b. I am/we are declared ineligible or post-disqualified upon receipt of your notice to such effect, and (i) I/we failed to timely file a request for reconsideration or (ii) I/we filed a waiver to avail of said right; and
 - c. I am/we are declared the bidder with the Lowest Calculated Responsive Bid, and I/we have furnished the performance security and signed the Contract.

IN WITNESS WHEREOF, I/We have hereunto set my/our hand/s this ____ day of *[month]*
[year] at *[place of execution]*.

[Insert NAME OF BIDDER OR ITS AUTHORIZED REPRESENTATIVE]
[Insert signatory's legal capacity] Affiant

[Jurat]

[Format shall be based on the latest Rules on Notarial Practice]

GPPB Resolution No. 16-2020, dated 16 September 2020



Contract Agreement Form for the Procurement of Goods (Revised)

[Not required to be submitted with the Bid, but it shall be submitted within ten (10) days after receiving the Notice of Award]

CONTRACT AGREEMENT

SUPPLY, DELIVERY AND INSTALLATION OF MODULAR OFFICE SYSTEM AND FURNITURE FOR VARIOUS SSS BRANCH OFFICES

ITB-SSS-Goods-2022-____

THIS AGREEMENT made between:

SOCIAL SECURITY SYSTEM, a government-owned and controlled corporation created pursuant to Republic Act No. 11199, with principal office address at SSS Building, East Avenue, Diliman, Quezon City, represented herein by its Approving Authority and (Position of Approving Authority), (Name of Approving Authority) and (Position of Signatory), (Name of signatory), duly authorized pursuant to Administrative Order _____, _____ (pertaining to Approving Authority) (Annex “A”) and Office Order _____, _____ (Annex “B”) (pertaining to signatories), hereinafter referred to as the “SSS”;

- a n d -

(NAME OF SUPPLIER), of legal age, Filipino, single/married, with principal address at _____, hereinafter referred to as the “Supplier”.

If corporation

(NAME OF SUPPLIER), a corporation duly created and existing pursuant to the laws of the Republic of the Philippines, with principal office address at _____, represented herein by its (Position of Signatory), (Name of Signatory), duly authorized pursuant to _____, _____, hereinafter referred to as the “Supplier”.

WHEREAS, the Entity invited Bids for certain goods and ancillary services, particularly [brief description of goods and services] (PROJECT) and has accepted a Bid by the Supplier for the supply of those goods and services in the sum of [contract price in words and figures in specified currency] (hereinafter called “the Contract Price”).

NOW THIS AGREEMENT WITNESSETH AS FOLLOWS:

1. In this Agreement words and expressions shall have the same meanings as are respectively assigned to them in the Conditions of Contract referred to.
2. The following documents as required by the 2016 revised Implementing Rules and Regulations of Republic Act No. 9184 shall be deemed to form and be read and construed as integral part of this Agreement, viz.:
 - a. Philippine Bidding Documents (PBDs);
 - i. Schedule of Requirements;
 - ii. Technical Specifications;
 - iii. General and Special Conditions of Contract; and
 - iv. Supplemental or Bid Bulletins, if any



- b. Supplier's bid, including the Eligibility requirements, Technical and Financial Proposals, and all other documents or statements submitted;

Bid form, including all the documents/statements contained in the Bidder's bidding envelopes, as annexes, and all other documents submitted (e.g., Bidder's response to request for clarifications on the bid), including corrections to the bid, if any, resulting from the Procuring Entity's bid evaluation;

- c. Performance Security;
- d. Notice of Award of Contract; and the Bidder's conforme thereto; and
- e. Other contract documents that may be required by existing laws and/or the Procuring Entity concerned in the PBDs. **Winning bidder agrees that additional contract documents or information prescribed by the GPPB that are subsequently required for submission after the contract execution, such as the Notice to Proceed, Variation Orders, and Warranty Security, shall likewise form part of the Contract.**

- 3. In consideration for the sum of *[total contract price in words and figures]* or such other sums as may be ascertained, *[Named of the bidder]* agrees to *[state the object of the contract]* in accordance with his/her/its Bid.
- 4. SSS agrees to pay the above-mentioned sum in accordance with the terms of the Bidding.

IN WITNESS whereof the parties hereto have caused this Agreement to be executed in accordance with the laws of the Republic of the Philippines on the date and place indicated in their respective acknowledgments.

[Insert Name and Signature]

[Insert Name and Signature]

[Insert Position of Signatory]

[Insert Position of Signatory]

for:

SSS

for:

[Insert Name of Supplier]



(In case of double acknowledgment which is usually used by the SSS)

SIGNED IN THE PRESENCE OF:

(Name of Certifying officer as to availability of funds)

(Position of Certifying Officer)

(Department/Office of Certifying Officer)

FUNDS AVAILABLE:

APP No.: _____

FIRST ACKNOWLEDGMENT

Republic of the Philippines)
_____) S.S.

BEFORE ME, a Notary Public for and in _____, Philippines, on this _____ day of _____ personally appeared:

Name	Competent Evidence of Identity	Date/Place of Issue

known to me to be the same person who executed the foregoing Agreement, consisting of _____ (____) pages, including this page and excluding annexes, and he/she/they acknowledged to me that the same is his/her/their free and voluntary act and deed as well as the free and voluntary act and deed of the principal he/she /they represent/s in this instance.

WITNESS MY HAND AND SEAL on the date and place first above written.

Doc. No. _____;
Page No. _____;
Book No. _____;
Series of 20__.



SIGNED IN THE PRESENCE OF:

SECOND ACKNOWLEDGMENT

Republic of the Philippines)
_____) S.S.

BEFORE ME, a Notary Public for and in _____, Philippines, on this _____ day of _____ personally appeared:

Name	Competent Evidence of Identity	Date/Place of Issue

known to me to be the same person who executed the foregoing Agreement, consisting of _____ (__) pages, including this page and excluding annexes, and he/she/they acknowledged to me that the same is his/her/their free and voluntary act and deed (if corporation to include succeeding phrase) as well as the free and voluntary act and deed of the principal he/she/they represent/s in this instance.

WITNESS MY HAND AND SEAL on the date and place first above written.

Doc. No. _____;
Page No. _____;
Book No. _____;
Series of 20__.

GPPB Resolution No. 16-2020, dated 16 September 2020

FORM-09



Omnibus Sworn Statement (Revised)

REPUBLIC OF THE PHILIPPINES)
CITY/MUNICIPALITY OF _____) S.S.

AFFIDAVIT

I, *[Name of Affiant]*, of legal age, *[Civil Status]*, *[Nationality]*, and residing at *[Address of Affiant]*, after having been duly sworn in accordance with law, do hereby depose and state that:

1. **Select one, delete the other:**

[If a sole proprietorship:] I am the sole proprietor or authorized representative of *[Name of Bidder]* with office address at *[address of Bidder]*;

[If a partnership, corporation, cooperative, or joint venture:] I am the duly authorized and designated representative of *[Name of Bidder]* with office address at *[address of Bidder]*;

2. **Select one, delete the other:**

[If a sole proprietorship:] As the owner and sole proprietor, or authorized representative of *[Name of Bidder]*, I have full power and authority to do, execute and perform any and all acts necessary to participate, submit the bid, and to sign and execute the ensuing contract for *[Name of the Project]* of the *[Name of the Procuring Entity]* as shown in the attached duly notarized Special Power of Attorney;

[If a partnership, corporation, cooperative, or joint venture:] I am granted full power and authority to do, execute and perform any and all acts necessary to participate, submit the bid, and to sign and execute the ensuing contract for *[Name of the Project]* of the *[Name of the Procuring Entity]*, as shown in the attached [state title of attached documents showing proof of authorization (e.g., duly notarized Secretary's Certificate, Board/Partnership Resolution, or Special Power of Attorney, whichever is applicable);];

3. *[Name of Bidder]* is not "blacklisted" or barred from bidding by the Government of the Philippines or any of its agencies, offices, corporations, or Local Government Units, foreign government/foreign or international financing institution whose blacklisting rules have been recognized by the Government Procurement Policy Board, **by itself or by relation, membership, association, affiliation, or controlling interest with another blacklisted person or entity as defined and provided for in the Uniform Guidelines on Blacklisting;**

4. Each of the documents submitted in satisfaction of the bidding requirements is an authentic copy of the original, complete, and all statements and information provided therein are true and correct;

5. *[Name of Bidder]* is authorizing the Head of the Procuring Entity or its duly authorized representative(s) to verify all the documents submitted;

6. **Select one, delete the rest:**

[If a sole proprietorship:] The owner or sole proprietor is not related to the Head of the Procuring Entity, members of the Bids and Awards Committee (BAC), the Technical Working Group, and the BAC Secretariat, the head of the Project Management Office or the end-user unit, and the project consultants by consanguinity or affinity up to the third civil degree;

[If a partnership or cooperative:] None of the officers and members of *[Name of Bidder]* is related to the Head of the Procuring Entity, members of the Bids and Awards Committee (BAC), the Technical Working Group, and the BAC Secretariat, the head of the Project Management Office or the end-user unit, and the project consultants by consanguinity or affinity up to the third civil degree;

[If a corporation or joint venture:] None of the officers, directors, and controlling stockholders of *[Name of Bidder]* is related to the Head of the Procuring Entity, members of the Bids and Awards Committee (BAC), the Technical Working Group, and the BAC Secretariat, the head



of the Project Management Office or the end-user unit, and the project consultants by consanguinity or affinity up to the third civil degree;

7. *[Name of Bidder]* complies with existing labor laws and standards; and
8. *[Name of Bidder]* is aware of and has undertaken the responsibilities as a Bidder in compliance with the Philippine Bidding Documents, which includes:
 - a) Carefully examining all of the Bidding Documents;
 - b) Acknowledging all conditions, local or otherwise, affecting the implementation of the Contract;
 - c) Making an estimate of the facilities available and needed for the contract to be bid, if any; and
 - d) Inquiring or securing Supplemental/Bid Bulletin(s) issued for the *[Name of the Project]*.
9. *[Name of Bidder]* did not give or pay directly or indirectly, any commission, amount, fee, or any form of consideration, pecuniary or otherwise, to any person or official, personnel or representative of the government in relation to any procurement project or activity.
10. **In case advance payment was made or given, failure to perform or deliver any of the obligations and undertakings in the contract shall be sufficient grounds to constitute criminal liability for Swindling (Estafa) or the commission of fraud with unfaithfulness or abuse of confidence through misappropriating or converting any payment received by a person or entity under an obligation involving the duty to deliver certain goods or services, to the prejudice of the public and the government of the Philippines pursuant to Article 315 of Act No. 3815 s.1930, as amended, or the Revised Penal Code.**

IN WITNESS WHEREOF, I have hereunto set my hand this ___ day of ___, 20__ at _____, Philippines.

[Insert NAME OF BIDDER OR ITS AUTHORIZED REPRESENTATIVE]

[Insert signatory's legal capacity]

Affiant

[Jurat]

[Format shall be based on the latest Rules on Notarial Practice]

GPPB Resolution No. 16-2020, dated 16 September 2020



Performance Securing Declaration (Revised)

[As alternative performance security to be submitted by the winning bidder within ten (10) days from receipt of Notice of Award]

REPUBLIC OF THE PHILIPPINES)

CITY OF _____) S.S.

PERFORMANCE SECURING DECLARATION

Invitation to Bid: [Insert Reference Number indicated in the Bidding Documents] To: [Insert name and address of the Procuring Entity]

I/We, the undersigned, declare that:

1. I/We understand that, according to your conditions, to guarantee the faithful performance by the supplier/distributor/manufacture/contractor/consultant of its obligations under the Contract, I/we shall submit a Performance Securing Declaration within a maximum period of ten (10) calendar days from the receipt of the Notice of Award prior to the signing of the Contract.
2. I/We accept that: I/we will be automatically disqualified from bidding for any procurement contract with any procuring entity for a period of one (1) year for the first offense, or two (2) years **for the second offense**, upon receipt of your Blacklisting Order if I/We have violated my/our obligations under the Contract;
3. I/We understand that this Performance Securing Declaration shall cease to be valid upon:
 - a. issuance by the Procuring Entity of the Certificate of Final Acceptance, subject to the following conditions:
 - i. Procuring Entity has no claims filed against the contract awardee;
 - ii. It has no claims for labor and materials filed against the contractor; and
 - iii. Other terms of the contract; or
 - b. replacement by the winning bidder of the submitted PSD with a performance security in any of the prescribed forms under Section 39.2 of the 2016 revised IRR of RA No. 9184 as required by the end-user.

IN WITNESS WHEREOF, I/We have hereunto set my/our hand/s this ____ day of [month] [year] at [place of execution].

*[Insert NAME OF BIDDER OR ITS
AUTHORIZED REPRESENTATIVE]*

[Insert signatory's legal capacity]
Affiant

[Jurat]

[Format shall be based on the latest Rules on Notarial Practice]



SUMMARY OF PROJECT BREAKDOWN (COST PER BRANCH)

Branch Name	Sub-limit
Lot I: NCR and Nearby Luzon Branches	21,526,973.24
SSS Malabon	3,937,222.00
SSS Pasay-Roxas	4,565,224.00
SSS Marikina	4,439,114.40
SSS Tagaytay	4,166,045.84
SSS Rosario-EPZA	4,419,367.00
Lot II: Luzon Branches	14,294,944.16
SSS Vigan	3,017,755.08
SSS Baler	1,348,308.00
SSS San Pedro	2,508,790.00
SSS Tuguegarao	4,625,000.00
SSS Tabaco	2,795,091.08
Lot III: VisMin Branches	19,352,144.56
SSS Valencia	2,971,934.00
SSS Bislig	2,970,562.07
SSS Danao	2,108,397.00
SSS Zamboanga	5,595,318.00
SSS Bago	3,275,950.00
SSS Sagay	2,429,983.49

