



Republic of the Philippines  
SOCIAL SECURITY SYSTEM  
East Avenue, Diliman, Quezon City

PROCUREMENT PLANNING & MANAGEMENT DEPARTMENT  
Tel. No. 8709-7198 loc 5504-5507/6391

April 13, 2024

Sir/Madam:

Please furnish us with your quotation on or before **APRIL 17, 2024 @ 10:00 AM** for the items listed in the attached **Request for Quotation (RFQ)**.

Kindly accomplish the **RFQ Form** together with the **Bidder's Information** and indicate your confirmation on the **Terms and Conditions** by signing the **Certification**.

Refer to the Instruction to Suppliers for the procedure on the submission of quotation.

Thank you.

Very truly yours,

**BILLY V. DIBDIB**  
Acting Head, PPMD

PHILGEPS REF. NO.: 10749779  
PUBLISHED DATE : 04/13/24  
POSTED BY : AMY

**REQUEST FOR QUOTATION (RFQ) FORM**

RFQ Number <b>24-04-036</b>	RFQ Date <b>April 13, 2024</b>	ABC <b>₱ 849,069.10</b> <b>(Part of P 2,000,000.00)</b>	APP NO. <b>2024-0087</b>
--------------------------------	-----------------------------------	---	-----------------------------

**Building and Maintenance for IPROPA - Pool**

Lot No.	Quantity	PARTICULARS	Bid/Cost Breakdown	
			Unit Cost	Total Cost
1	1 Lot	<b>Repair of Perimeter Fence at SSS East Triangle Property</b>  ABC: ₱ 849,069.10 / Lot	₱ _____ / Lot	₱ _____

**Total Offered Quotation (Inclusive of VAT) in words:**

\_\_\_\_\_

\_\_\_\_\_

**Please completely fill-out and submit this form together with**

**Annex A – Technical Specification / Statement of Compliance**  
**Annex B – Bill of Quantities**  
**Annex C – Plans**

<b>Price Validity</b>	Three (3) Months
<b>Delivery Terms</b>	Sixty-five (65) Calendar Days upon receipt of approved Purchase Order / Job Order including the period for inspection and acceptance of 1-5 working days.
<b>Delivery Place</b>	To be rendered at East Triangle Property, East Avenue cor. EDSA, Quezon City.
<b>Payment Terms</b>	<ul style="list-style-type: none"> <li>• Government Terms</li> <li>• SSS shall withhold the applicable taxes from the amount payable in accordance with the BIR regulations.</li> <li>• One-time payment</li> <li>• Payment is upon delivery of items/services and submission of billing documents; and shall be directly credited to the Supplier’s bank account.</li> </ul>

**BIDDER’S INFORMATION**

<b>Business Name</b>	<b>Address</b>		
<b>Name of Company Representative</b>	<b>Email Address</b>	<b>Telephone/Mobile Number</b>	
<b>PhilGEPS Registration No.</b>	<b>SS Number</b>	<b>BIR TIN</b>	

## TERMS AND CONDITIONS

1. **For contract price amounting to P100,000.00 and above**, the winning Supplier shall be required to post a Performance Security from receipt of Notice of Award equivalent to % of Contract Price as follows:
  - 5% (Goods & Consulting Services) or 10% (Infrastructure) Cash, Cashier's/Manager's Check, Bank Draft/Guarantee, or
  - 30% Surety Bond callable upon demand.
2. If two (2) or more Suppliers submitted the same price quotation and have been post-qualified as the suppliers with Lowest Calculated and Responsive Quotations, the procuring unit shall use "draw lots" or similar method of chance to break the tie.
3. Alternative offer shall not be allowed. Any bid exceeding the ABC shall be a ground for disqualification.
4. Incompletely filled out Bid Breakdown shall be considered non-responsive and automatically disqualified but specifying a zero (0), dash (-), or the word "free" for the said item would mean that it is being offered for FREE to the SSS.
5. In case of discrepancy between the submitted quotation and the quotation after arithmetical correction, the supplier shall be informed of such discrepancy for confirmation of the new amount. **If the bidder fails to confirm the arithmetical corrections within three (3) calendar days from receipt of notification, the quotation as calculated shall be deemed confirmed.**
6. In case a prospective supplier/service provider submits a filled-out RFQ with a supporting document (i.e., a price quotation in a different format), both documents shall be considered provided that the terms and conditions stated therein is in conformity with the requirements of the RFQ. **In case of discrepancies, the submitted quotation shall be considered ineligible or not compliant.**
7. Quantity is subject to change but not to exceed the quantity in the approved PO/JO/LO.
8. Award shall be on a per **"LOT BASIS"** and the date of conduct/start of the project is subject to change.

## INSTRUCTIONS TO SUPPLIERS

1. For clarification of details, please contact **Procurement Planning and Management Department** at **8709-7198 local 5505-5507** or via e-mail **ppmd@sss.gov.ph/bacsealedquotations@sss.gov.ph**.
2. Supplier should indicate "COMPLY" or "NOT COMPLY" in the STATEMENT OF COMPLIANCE COLUMN, if applicable. Failure to indicate compliance and non-compliance will mean automatic disqualification.
3. Sealed Quotations may be submitted through the following:
  - a. DROP BOX located at Procurement Planning & Management Dept. (PPMD), 2nd Floor, SSS Main Bldg., East Ave., Diliman, Quezon City. It shall be addressed to Ms. BILLY V. DIBDIB – Acting Head of the PPMD. Indicate in the sealed envelope the RFQ Number, company name, name of company representative, business address, and contact details.
  - b. ELECTRONIC MAIL at **bacsealedquotations@sss.gov.ph** with the following requirements:
    - i. Quotations and attachments should be in portable document format (pdf), compressed/ziped and protected by a password. (See attached Guide in Creating password protected zip file folder.)
    - ii. File name of the zip file folder shall be by **RFQ number and Project Title**.
    - iii. The Supplier who timely submitted its Sealed Quotation but who fails to provide its password on the date and time of opening shall be disqualified.
    - iv. Passwords shall be made available only through email (**bacsealedquotations@sss.gov.ph**) or **SMS (09062603807)** during opening of bids which is scheduled on:

**DATE: APRIL 17, 2024** **TIME: 1:30 PM – 2:00 PM**

## GENERAL CONDITIONS OF THE CONTRACT

1. The SUPPLIER shall deliver the goods in accordance with the description and quantity specifications of the Purchase Order/Job Order.
2. The SUPPLIER shall deliver the goods within the period indicated in the Purchase Order. A penalty of 1/10 of 1% of the total amount of the items shall be imposed for every day of delay in delivery.
3. The SUPPLIER shall deliver Goods/Services which must all be fresh stock, brand-new, unused, properly sealed, and which are not set to expire within two (2) years from date of delivery to the SSS, if applicable.
4. The SUPPLIER warrants that all the Goods/Services have no defects arising from design, materials, or workmanship or from any act or omission of the Supplier or the manufacturer that may develop under normal use of consumables, if applicable.
5. For Goods, the SUPPLIER shall replace any defective item within twenty-four (24) hours from the time that it was notified by the SSS of the defect. Defects detected only after the item is installed and used are covered by the replacement warranty which will be in effect for every item until its expiry date. Replacement of defective item shall have no cost on the SSS, if applicable.
6. To assure that manufacturing defects shall be corrected by the SUPPLIER, a warranty security shall be required from the SUPPLIER for a minimum of three (3) months in the case of expendable items, or a minimum period of one (1) year in the case of non-expendable items, after the acceptance of the delivered items. The obligation for the warranty shall be covered, at the Supplier's option, by either retention money in an amount equivalent to five percent (5%) of total purchase price, or a special bank guarantee equivalent to five percent (5%) of the total purchase price with validity period starting from the date of acceptance. The said amounts shall only be released after the lapse of the warranty period
7. If the SUPPLIER, having been notified, fails to remedy the defect(s) within the specified period, the SSS may proceed to take such remedial action as may be necessary, at the SUPPLIER's risk and expense and without prejudice to any other rights which the SSS may have against the SUPPLIER under these Terms and Conditions and under the applicable law.
8. The pricing of the Goods/Services shall be in Peso and inclusive of Twelve Percent (12%) Value-Added Tax (VAT).

## MISCELLANEOUS PROVISIONS

1. **Confidentiality.** Neither Party shall, without the prior written consent of the other, disclose or make available to any person, make public, or use directly or indirectly, except for the performance and implementation of the works, any confidential information acquired from an information holder in connection with the performance of this Agreement, unless: (i) the information is known to the disclosing Party, as evidenced by its written records, prior to obtaining the same from the information holder and is not otherwise subject to disclosure restrictions on the disclosing Party, (ii) the information is disclosed to the disclosing Party by a third party who did not receive the same, directly or indirectly, from an information holder, and who has no obligation of secrecy with respect thereto, or (iii) required to be disclosed by law.

The obligation of confidentiality by both Parties, as provided herein, shall survive the termination of this Agreement.

2. **Merger and Consolidation.** In case of merger, consolidation or change of ownership of the SUPPLIER with another company, it is the responsibility of the surviving company/consolidated company/acquiring entity to inform the SSS of the change in corporate structure/ownership. Failure to do so shall translate in such company assuming all liabilities of the acquired/merged company under this Agreement.
3. **Force Majeure.** The SUPPLIER shall not be liable for forfeiture of its performance security, liquidated damages, or termination for default if and to the extent that the SUPPLIER's delay in performance or other failure to perform its obligations under this Agreement is the result of a force majeure.

For purposes of this Agreement the terms "force majeure" and "fortuitous event" may be used interchangeably. In this regard, a fortuitous event or force majeure shall be

interpreted to mean an event which the SUPPLIER could not have foreseen, or which though foreseen, was inevitable. It shall not include ordinary unfavorable weather conditions; and any other cause the effects of which could have been avoided with the exercise of reasonable diligence by the SUPPLIER. Such events may include, but not limited to, acts of the SSS in its sovereign capacity, wars or revolutions, fires, floods, epidemics, quarantine restrictions, and freight embargoes.

4. **Non-Assignment.** Neither Party may assign the Contract in whole or in part without the consent of the other Party.
5. **Waiver.** Failure by either Party to insist upon the other the strict performance of any of the terms and conditions hereof shall not be deemed a relinquishment or waiver of any subsequent breach or default of the terms and conditions hereof, which can only be deemed made if expressed in writing and signed by its duly authorized representative. No such waiver shall be construed as modification of any of the provisions of this Agreement or as a waiver of any past or future default or breach hereof, except as expressly stated in such waiver.
6. **Cumulative Remedies.** Any and all remedies granted to the Parties under the applicable laws and this Agreement shall be deemed cumulative and may, therefore, at the sole option and discretion, be availed of by the aggrieved Party simultaneously, successively, or independently.
7. **No Employer-Employee Relationship.** It is expressly and manifestly understood and agreed that the employees of the SUPPLIER assigned to perform the PROJECT are not employees of the SSS. Neither is there an employer-employee relationship between the SSS and the SUPPLIER.

This Agreement does not create an employer-employee relationship between the SSS and the SUPPLIER including its personnel; that the PROJECT rendered by the personnel assigned by the SUPPLIER to the SSS in the performance of its obligation under this Agreement do not represent government service and will not be credited as such; that its personnel assigned to the SSS are not entitled to benefits enjoyed by SSS' officials and employees such as Personal Economic Relief Allowance (PERA), Representation and Transportation Allowance (RATA), ACA, etc.; that these personnel are not related within the third degree of consanguinity or affinity to the contracting officer and appointing authority of the SSS; that they have not been previously dismissed from the government service by reason of an administrative case; that they have not reached the compulsory retirement age of sixty-five (65); and that they possess the education, experience and skills required to perform the job. The SUPPLIER hereby acknowledges that no authority has been given by the SSS to hire any person as an employee of the latter. Any instruction given by the SSS or any of its personnel to the SUPPLIER's employees is to be construed merely as a measure taken by the former to ensure and enhance the quality of PROJECT performed hereunder. The SUPPLIER shall, at all times, exercise supervision and control over its employees in the performance of its obligations under this Agreement.

8. **Partnership.** Nothing in this Agreement shall constitute a partnership between the parties. No Party or its agents or employees shall be deemed to be the agent, employee or representative of any other Party.
9. **Compliance with SS Law.** The SUPPLIER shall report all its employees to the SSS for coverage and their contributions, as well as all amortizations for salary/education/calamity and other SSS loans shall be updated. Should the SUPPLIER fail to comply with its obligation under the provisions of the SS Law and Employees' Compensation Act, the SSS shall have the authority to deduct any unpaid SS and EC contributions, salary, educational, emergency and/or calamity loan amortizations, employer's liability for damages, including interests and penalties from the SUPPLIER's receivables under this Agreement.

Further, prescription does not run against the SSS for its failure to demand SS contributions or payments from the SUPPLIER. Moreover, the SUPPLIER shall forever hold in trust SS contributions or payments of its employees until the same is fully remitted to the SSS.

10. **Compliance with Labor Laws.** The SUPPLIER, as employer of the personnel assigned to undertake the PROJECT, shall comply with all its obligations under existing laws and their implementing rules and regulations on the payment of minimum wage, overtime pay, and other labor-related benefits as well as remittances or payment of the appropriate

amount or contributions/payment (SSS, EC, Pag-IBIG, PhilHealth and taxes) with concerned government agencies/offices.

It is agreed further, that prior to the release of any payment by the SSS to the SUPPLIER, its President or its duly authorized representative, shall submit a sworn statement that all moneys due to all the employees assigned to the PROJECT as well as benefits by law and other related labor legislation have been paid by the SUPPLIER and that he/she assumed full responsibility thereof.

11. **Compliance with Tax Laws.** The SUPPLIER shall, in compliance with tax laws, pay the applicable taxes in full and on time and shall regularly present to the SSS within the duration of this Agreement, tax clearance from the Bureau of Internal Revenue (BIR) as well as copy of its income and business tax returns duly stamped by the BIR and duly validated with the tax payments made thereon, if applicable. Failure by the SUPPLIER to comply with the foregoing shall entitle the SSS to suspend payment of the Contract Price.
12. **Liquidated Damages.** If the SUPPLIER fails to satisfactorily deliver any or all of the Goods and/or to perform the Services within the period(s) specified in the PBD inclusive of duly granted time extensions if any, the SSS shall, without prejudice to its other remedies under this Agreement and under the applicable law, deduct from the Contract Price, as liquidated damages, the applicable rate of one tenth (1/10) of one (1) percent of the cost of the unperformed portion for every day of delay until actual delivery or performance. Once the amount of liquidated damages reaches ten percent (10%), the SSS may rescind or terminate this Agreement, without prejudice to other courses of action and remedies open to it.
13. **Hold Free and Harmless.** The SUPPLIER agrees to defend, indemnify, and hold the SSS free and harmless from any and all claims, damages, expenses, fines, penalties and/or liabilities of whatever nature and kind, whether in law or equity, that may arise by reason of the implementation of the Agreement. In addition, the SUPPLIER agrees to indemnify the SSS for any damage as a result of said implementation.
14. **Settlement of Disputes.** All actions and controversies that may arise from the Contract involving but not limited to demands for specific performance of the obligations as specified herein and/or in the interpretation of any provisions or clauses contained herein, shall, in the first instance, be settled within thirty (30) calendar days through amicable means, such as, but not limited to mutual discussion. Should the dispute remain unresolved by the end of the afore-mentioned period, the dispute shall be settled in accordance with applicable provisions of Republic Act No. 9285, otherwise known as the Alternative Dispute Resolution Act of 2004.
15. **Venue of Actions.** Any suit or proceeding arising out of or relating to the contract shall be instituted in the appropriate court in Quezon City, the Parties hereto waiving any other venue.
16. **Governing Law.** This Agreement shall be governed by and interpreted according to the laws of the Republic of the Philippines.
17. **Amendments.** This Agreement may be amended only in writing and executed by the Parties or their duly authorized representatives.
18. **Separability.** If any one or more of the provisions contained in this Agreement or any document executed in connection herewith shall be invalid, illegal or unenforceable in any respect under any applicable law, then: (i) the validity, legality and enforceability of the remaining provisions contained herein or therein shall not in any way be affected or impaired and shall remain in full force and effect; and (ii) the invalid, illegal or unenforceable provision shall be replaced by the parties immediately with a term or provision that is valid, legal and enforceable and that comes closest to expressing the intention of such invalid, illegal or unenforceable term or provision.
19. **Binding Effect.** This Agreement shall be binding upon the Parties hereto, their assignee/s and successor/s-in-interest.
20. **Non-Publicity.** No press release in oral, written or electronic form shall be issued covering this transaction without prior written approval of the SSS. Inclusion in any reference lit shall also be undertaken only upon prior written approval of the SSS.

**CERTIFICATION**

**This is to certify that my company conforms with the above Terms and Conditions, and that the data/quotation indicated is true, correct, and valid.**

\_\_\_\_\_  
Owner/Company Representative  
(Signature over Printed Name)

\_\_\_\_\_  
Date

**Note: The Supplier must sign over printed name the CERTIFICATION above. Non-compliance with this instruction is a ground for disqualification of submitted quotation.**

## ANNEX A. TECHNICAL SPECIFICATIONS

Suppliers/Bidders should indicate "**COMPLY**" or "**NOT COMPLY**" to each specification below. Please do not leave any portion blank as it will result to disqualification of quotation/bid.

### Lot 1: Repair of Perimeter Fence at SSS East Triangle Property

Item	Specification	Statement of Compliance										
1	<p><b>SCOPE OF WORKS</b></p> <p>The work contemplated under this contract shall consist of the furnishing of all materials, labor, plans, tools and equipment, permits including the satisfactory performance of all work necessary for the complete execution of all the work as shown on the plans, specifications and other contract documents.</p> <p>Materials deemed necessary to complete the work but not specifically mentioned in the specifications, working drawings or in the other contract documents are inferred, and shall be supplied and installed by the contractor without extra cost to the owner. Such material shall be of the highest quality available, installed and applied in workmanlike manner at prescribed or appropriate locations.</p> <p><b>A. GENERAL REQUIREMENT</b></p> <ol style="list-style-type: none"> <li>1. Renovation Permits / Clearances</li> <li>2. Installation of temporary facility (Using pre-painted roof sheets, G.I Pipes, etc.) including Water and Electricity Consumption</li> </ol> <p><b>B. SITE PREPARATION</b></p> <ol style="list-style-type: none"> <li>1. Excavation &amp; Backfilling including Demolition and Restoration of affected structures (Including dismantling of existing dilapidated roofing and restoration/replacement of existing board-up from SSS Gate to DPWH Wall)               <ol style="list-style-type: none"> <li>1.1. All foundation shall be excavated to grades and dimensions indicated in the drawing.</li> <li>1.2. If the required bearing capacity is not obtained at the excavation indicated of the drawings, the excavations shall be continued until such safe bearing power is obtained.</li> <li>1.3. Footing shall not be placed on fill.</li> <li>1.4. Excavations shall be protected from damage of rainwater, spring water and backing of drains. Drainages shall be built for this purpose. Shoring, bracing and sheathing shall be provided for the safety of necessary support for adjoining walls, soil, building and fences.</li> <li>1.5. All excavations shall be backfilled presently as work permits after concrete walls and pipes have attained full design strength.</li> <li>1.6. Materials for filling shall be free from waste and objectionable matters. Filled excavations shall be thoroughly tamped.</li> <li>1.7. All filling materials, whether native to the site or imported, shall be free of debris, roots, vegetation, or other deleterious materials. All earth fill materials, sand and gravel shall be free of any clods or stones larger than 50mm in their largest dimension except as otherwise shown or specified.</li> <li>1.8. Bedding materials shall be used as shown in the drawings and as directed by the PE. The stone shall be 19mm (3/4 in.) maximum size graded by weight as follows:                   <table border="1" style="margin-left: 20px; width: 80%; border-collapse: collapse;"> <thead> <tr> <th style="text-align: center;">Sieve Size (Square Openings)</th> <th style="text-align: center;">Percent by Weight</th> </tr> </thead> <tbody> <tr> <td style="text-align: center;">19 mm (3/4 inch)</td> <td style="text-align: center;">90-100</td> </tr> <tr> <td style="text-align: center;">12 mm (1/2 inch)</td> <td style="text-align: center;">10-50</td> </tr> <tr> <td style="text-align: center;">9.5 mm (3/8 inch)</td> <td style="text-align: center;">0-20</td> </tr> <tr> <td style="text-align: center;">4.75 mm (No. 4)</td> <td style="text-align: center;">0-5</td> </tr> </tbody> </table> </li> </ol> </li> </ol>	Sieve Size (Square Openings)	Percent by Weight	19 mm (3/4 inch)	90-100	12 mm (1/2 inch)	10-50	9.5 mm (3/8 inch)	0-20	4.75 mm (No. 4)	0-5	
Sieve Size (Square Openings)	Percent by Weight											
19 mm (3/4 inch)	90-100											
12 mm (1/2 inch)	10-50											
9.5 mm (3/8 inch)	0-20											
4.75 mm (No. 4)	0-5											



Item	Specification	Statement of Compliance
	<p>2. Installation of safety signages/materials and protective cover (Caution Signs - "Area Under Construction", "Construction Site", etc.)</p> <p>3. Cleaning of area after work including hauling and disposal of waste/unusable materials and debris</p> <p><b>C. REPAIR OF FENCE</b></p> <p>1. Portland Cement</p> <p>1.1. Portland cement shall conform to the standard specifications for consignment numbers, dates of dispatch and delivery quantity and dates of use.</p> <p>1.2. At time of use, all cements shall be free flowing and free of lumps. Lumpy or air set cement shall not be used unless the lumps can be crushed to power between fingers and thumb.</p> <p>1.3. Cement delivered in bags shall be stored one well-ventilated waterproof sheds with suitable elevated wooden floors and shall be kept perfectly dry.</p> <p>2. Concrete Aggregates</p> <p>2.1. Aggregates used in concrete shall conform to the standard specifications for concrete aggregates.</p> <p>2.2. Aggregate failing to meet those specifications, but which have shown by approved laboratory tests to produce concrete of the required quality may be used.</p> <p>2.3. Aggregates shall be quarried or washed on fresh water and shall contain no more than one percent silt by weight.</p> <p>2.4. The coarse aggregate of different sizes shall be stored in a separate bunkers or piles in such manners as to prevent aggregation inclusion and contamination by dirt and other foreign materials.</p> <p>3. Water</p> <p>3.1. Water used in concrete shall be clean, free from oils, alkalis, or other matter detrimental to the quality or durability of concrete.</p> <p>3.2. Water shall be stored in tanks and not be allowed or exposed to dust and falling leaves.</p> <p>4. Reinforcing Steel Bar</p> <p>4.1. Steel reinforcing bars shall be of the yield grade in the structural drawings and in the job specifications sheets and conforming to ASTM a615, "Specification for deformed billet. Steel bars for concrete reinforcements specified herein and/or the details on the drawings. Shop drawings are required for all structural steel and shall be submitted to the engineers/consultant for approval.</p> <p>4.2. Unless otherwise indicated in the plans, reinforcing bars shall be deformed steel bars and shall conform to the requirements of the "specification for billet- Steel bars for concrete reinforcement".</p> <p>4.3. Reinforcing steel shall be transported and stored at the site in such a way as to prevent damage or deterioration of the steel for use in the reinforced concrete.</p> <p>4.4. All reinforcing steel shall be free from mill scale, oil, grease, tar, paint, etc., and loose rust shall be removed before use.</p> <p>4.5. Use G.I wire, gauge No. 16 for binding reinforcing steel bars.</p> <p>4.6. Welded joints shall be done in accordance with the American Welding society.</p>	

Item	Specification	Statement of Compliance
	<p>4.7. All reinforcements shall be carefully cut and bent in accordance with the drawings and schedules.</p> <p>5. Concrete Proportions and Consistency</p> <p>5.1. The proportions of aggregate to cement for any concrete shall be such as to produce a mixture that will work readily. Concrete proportions for footing shall be 1:2:3 for beams and Columns shall be 1:2:4 and shall produce a concrete strength of <math>f_c=20.7</math> Mpa.</p> <p>With the placement method used into corners and angles of forms around reinforcements, segregation of materials in the mixtures or collection of excess free water on the surface shall not be permitted. The slump of concrete shall be the minimum that is practicable.</p> <p>When vibrators are used to consolidate concrete, the slump shall not exceed 4 inches; otherwise, the slump shall not exceed 6 inches. Addition of water during hot weather to maintain the same slump must be compensated by adding more cement or retain the correct water-cement ratio.</p> <p>5.2. The method of measuring concrete materials shall be such that proportions can be accurately controlled and easily checked at any time during the work. 28 days concrete strengths shall be tested and shall be proportioned according to the results of the test.</p> <p>6. Formworks</p> <p>6.1. Woods forms shall be sound, smooth, properly seasoned, good quality lumber, free from large, loose knots and otherwise suitable to facilitate finishing exposed concrete surface.</p> <p>6.2. Formworks shall be built to resist distortion or deflection, tight to prevent loss of liquid from the concrete.</p> <p>6.3. Formworks shall be coated with form oil of an approved make and care shall be taken to avoid the spilling of oil on reinforcement.</p> <p>7. Mixing and Pouring of Concrete</p> <p>7.1. Unless otherwise authorized by the supervising engineer, concrete shall be machine mixed at the site.</p> <p>7.2. Concrete shall be thoroughly mixed in a batch mixer of an approved size and type which shall ensure a uniform distribution of the materials throughout the mass, so that the mixer is homogenous and uniform in color.</p> <p>7.3. The first batch of concrete materials placed in the mixer shall contain a sufficient excess of cement, sand and water to cut the inside of the drain with-out reducing the required mortar content of the mix.</p> <p>7.4. Hand mixing shall only be allowed in case of emergencies and only upon direct supervision of the engineer-in-charge. It must be done in watertight platform.</p> <p>7.5. In preparation for the placing of concrete, all sawdust, chips and other construction debris and all extraneous matter will be removed from the interior of forms, struts and stays.</p> <p>7.6. Temporary discontinuance of pouring shall be referred to the supervising.</p>	

Item	Specification	Statement of Compliance
	<p>8. Concrete Hollowblocks</p> <p>8.1. Materials blocks shall be laid in accordance with the manufacturer's specifications and recommendation. Strength of blocks shall be specified in the drawings or in the specific job requirement sheet.</p> <p>All concrete hollow blocks to be used are stated in the plans and drawings.</p> <p>Class B (1:2-1/2:5) Mixtures shall be used for all concrete hollow blocks and shall be reinforced with 12mm dia. RSB at .80 meters O.C vertical, and horizontal at every three layers.</p> <p>Concrete hollow blocks shall be 400 psi minimum.</p> <p>8.2. Grouting</p> <p>Grout shall be sufficiently fluid to ensure complete filling of all sections of the masonry requiring grout. Grout shall not contain more than 7-1/2 gallons of water per sack of cement. In case of honeycomb on structural members, use pressure - injected epoxy grout, approved by the structural engineer or the engineer/consultants.</p> <p>8.3. Joints</p> <p>Unless otherwise specified or detailed on plans, horizontal and vertical mortar joints shall 3/8" or 10mm thick with full mortar coverage on the face shells and wed surrounding the cells to be filled. All joints shall be solidly filled. Furrowing will not be allowed.</p> <p><b>D. PAINTING WORKS</b></p> <p>1. Surface preparation of all painting works (sanding, application of skimcoat and primer)</p> <p>2. Painting of newly repaired perimeter fence</p>	
II	<p><b>WORKMANSHIP</b></p> <p>All required phases of work shall be done by skilled and competent men who regularly engage or specialize in the type of work specified. Workmanship shall be the very best trade practice.</p>	
III	<p><b>SITE EXAMINATION</b></p> <p>Examine the site premises and all conditions apparent and visible therein. Consider all such conditions that may affect work.</p> <p>Measure every existing work/structure at site. Verify all given dimensions and deviations. It shall be understood that the work covers all exposed external surfaces regardless of measurements made</p>	
IV	<p><b>PROTECTION OF WORK AND PROPERTY</b></p> <p>Provide adequate protection for existing structures and other areas not affected by the work specified and the ground below. Place warning signs where work is being undertaken.</p>	
V	<p><b>CLEANING</b></p> <p>Leave premises clean, neat and orderly. Remove all stains, spots, blemishes, soil dirt from all finished work.</p> <p>Remove all excess materials, used containers, tools, equipment and supplies out of the work area during the progress upon completion of work.</p>	
VI	<p><b>SUBMITTALS</b></p> <p>Samples of finishes, furnished materials and equivalent materials for approval by the Engineering and Facilities Management Department prior to installation / application.</p>	
VII	<p><b>WORK HOURS/ SCHEDULE</b></p> <p>7:00am Onwards</p>	

## DOCUMENTARY REQUIREMENTS

### Instructions:

#### Submission of documentary requirements together with the sealed quotation, as follows:

- a. Notarized Omnibus Sworn Statement (NOSS) with attached Notarized Special Power of Attorney (SPA) for Sole Proprietorship or Secretary's Certificate for Partnership/ Corporation, authorizing the representative, if any, to sign on behalf of the owner/company (for ABCs above P50,000.00)

#### Suppliers that have previously submitted the following requirements that are still valid may no longer resubmit a copy:

- b. Mayor's/Business Permit<sup>1</sup>
- c. PhilGEPS Registration Number (Red Membership) or PhilGEPS Certificate (Platinum Membership)
- d. Latest Annual Income / Business Tax Return (for ABCs above P500,000.00)

**NOTE:** Submitted documents are subject to verification and validation of its authenticity, genuineness, validity, and completeness. Incomplete submission, concealment, falsification, or misrepresentation of any of the documents submitted, or the contents thereof is a ground for disqualification of submitted quotation.

---

<sup>1</sup> For individuals engaged under Sec. 53.6, 53.7 and 53.9 of the IRR of RA No. 9184, only the BIR Certificate of Registration shall be submitted in lieu of DTI Registration and Mayor's Permit.

## ANNEX B. BILL OF QUANTITIES

Note: Incompletely filled out Cost/Bid Breakdown shall be considered non-responsive and automatically disqualified but specifying a zero (0), dash (-), or the word "free" for the said item would mean that it is being offered for FREE to the SSS.

ITEM	DESCRIPTION	QTY.	UNIT	MATERIALS & LABOR/EQUIPMENT (Including Mark-up, Mobilization & 12% VAT)	
				UNIT COST	TOTAL
(A)	(B)	(C)	(D)	(E)	(F) = (C x E)
<b>A. GENERAL REQUIREMENTS</b>					
1.0	Renovation Permits / Clearances	1.00	lot		
2.0	Installation of temporary facility (Using pre-painted roof sheets, G.I Pipes, etc.) including Water and Electricity Consumption	1.00	lot		
<b>SUB-TOTAL A – GENERAL REQUIREMENT</b>					
<b>B. SITE PREPARATION</b>					
1.0	Excavation & Backfilling including Demolition and Restoration of affected structures (Including dismantling of existing dilapidated roofing and estoration/replacement of existing board-up from SSS Gate to DPWH Wall)	1.00	lot		
2.0	Installation of safety signages/materials and protective cover (Caution Signs - "Area Under Construction", "Construction Site", etc.)	1.00	lot		
3.0	Cleaning of area after work including hauling and disposal of waste/unusable materials and debris	1.00	lot		
<b>SUB-TOTAL B – SITE PREPARATION</b>					
<b>C. REPAIR OF FENCE</b>					
1.0	Repair of Fence including footing, column, tie beam, masonry wall, formworks, etc. (See Attached Detailed Structural Plan)				
	<ul style="list-style-type: none"> <li>- CHB #4</li> <li>- Sand</li> <li>- Gravel</li> <li>- Cement, 40 kg</li> <li>- G.I. Tie Wire, 0.3m - #16</li> <li>- DBS steel bar #10mm x 6m</li> <li>- DBS steel bar #12mm x 6m</li> <li>- DBS steel bar #16mm x 6m</li> <li>- Ordinary Nail</li> <li>- Plywood</li> <li>- Cocolumber</li> </ul>	1.00	lot		
<b>SUB-TOTAL C – CONSTRUCTION OF FENCE</b>					
<b>D. PAINTING WORKS</b>					
1.0	Painting of newly repaired perimeter fence including surface preparations				
	<ul style="list-style-type: none"> <li>- Flat Latex paint (1 coat)</li> <li>- Semi Gloss Latex Paint (2 coats)</li> <li>- SkimCoat, 20 kgs</li> <li>- 7" Paint Roller (Cloth)</li> <li>- 1" Paint Brush</li> <li>- Roller Pan</li> <li>- Sand Paper #120</li> <li>- Rags</li> </ul>	1.00	lot		
<b>SUB-TOTAL D – PAINTING WORKS</b>					
<b>TOTAL PROJECT COST</b>					

# ANNEX C. PLANS

## GENERAL CONSTRUCTION NOTES

### GENERAL NOTES

1. IN THE INTERPRETATION OF THE DRAWING, INDICATED DIMENSION SHALL GOVERN AND DISTANCES AND SIZES SHALL NOT BE SCALED FOR CONSTRUCTION PURPOSES.
2. IN PREFERENCE TO OTHER DRAWINGS, SEE ARCHITECTURAL DRAWINGS FOR DEPRESSIONS IN FLOOR SLABS, OPENINGS IN THE WALLS AND SLABS, INTERIOR PARTITIONS, LOCATION OF DRAINS ETC.
3. IN CASE OF DISCREPANCIES AS TO LAYOUT, DIMENSIONS, AND ELEVATIONS BETWEEN THE STRUCTURAL PLANS, AND ARCHITECTURAL DRAWINGS, THE CONTRACTOR SHALL NOTIFY BOTH THE STRUCTURAL ENGINEER AND THE ARCHITECT.
4. ALL CONCRETE WORK SHALL BE DONE IN ACCORDANCE WITH THE ACI 318 95 BUILDING CODE REQUIREMENTS FOR REINFORCED CONCRETE AND ALL STRUCTURAL STEEL WORK ACCORDING TO AISC SPECIFICATION (9TH EDITION) IN SO FAR AS THEY DO NOT CONFLICT WITH THE LOCAL BUILDING CODE REQUIREMENT.
5. ACI REFERS TO AMERICAN CONCRETE INSTITUTE, AISC TO AMERICAN INSTITUTE OF STEEL CONSTRUCTION AND ASTM TO AMERICAN SOCIETY FOR TESTING MATERIALS.
6. CONSTRUCTION NOTES AND TYPICAL DETAILS APPLY TO ALL DRAWINGS UNLESS OTHERWISE SHOWN OR NOTED. MODIFY TYPICAL DETAILS AS DIRECTED TO MEET SPECIAL CONDITIONS.
7. SHOP DRAWINGS WITH ERECTION AND PLACING DIAGRAMS OF ALL STRUCTURAL STEELS, MISCELLANEOUS IRON, PRE-CAST CONCRETE, ETC. SHALL BE SUBMITTED FOR ENGINEERS APPROVAL BEFORE FABRICATION.
8. CONTRACTOR SHALL NOTE AND PROVIDE ALL MISCELLANEOUS CURBS, SILLS, STOOLS, EQUIPMENTS AND MECHANICAL BASIS THAT ARE REQUIRED BY THE ARCHITECTURAL, ELECTRICAL, AND MECHANICAL DRAWINGS.
9. ALL RESULTS OF MATERIAL TESTING FOR CONCRETE, REINFORCING BARS, & STRUCTURAL STEEL MUST BE NOTED & APPROVED BY THE STRUCTURAL ENGINEER.

### NOTES ON REINFORCEMENTS

1. UNLESS OTHERWISE NOTED IN PLANS, THE YIELD STRENGTH OF THE REINFORCING BARS SHALL BE:
  - A. FOOTINGS, FOOTING BEAMS AND GIRDERS  $f_y = 275 \text{ MPa (40,000 psi)}$
  - B. COLUMNS AND SHEAR WALLS  $f_y = 275 \text{ MPa (40,000 psi)}$
  - C. BEAMS AND GIRDER  $f_y = 275 \text{ MPa (40,000 psi)}$
  - D. NON-LOAD BEARING WALL PARTITIONS, BEDDED SLABS, FLOOR & ROOF SLABS, PARAPETS, CATCH BASIN, SIDE WALK  $f_y = 227.5 \text{ MPa (33,000 psi)}$
2. ALL REINFORCING BAR SIZE 10MM OR LARGER SHALL BE DEFORMED IN ACCORDANCE WITH ASTM A 706. BARS SMALLER THAN 10MM MAY BE PLAIN.
3. SPLICES SHALL BE SECURELY WIRED TOGETHER AND SHALL BE STAGGERED WHEREVER POSSIBLE.

### NOTES ON COLUMNS

1. PROVIDE EXTRA SETS OF TIES AT 100mm O.C. FOR TIED COLUMN AND REINFORCEMENT ABOVE AND BELOW BEAM COLUMN CONNECTIONS FOR A DISTANCE FROM FACE OF CONNECTION EQUAL TO THE GREATER OF THE OVERALL THICKNESS OF COLUMN,  $\frac{1}{4}$  THE CLEAR HEIGHT OF COLUMN OR 450mm.
2. COLUMN TIES SHALL BE PROTECTED EVERYWHERE BY A COVERING CONCRETE CAST MONOLITHICALLY WITH THE CORE WITH THE MINIMUM THICKNESS OF 40mm AND NOT LESS THAN 40 TIMES THE MAXIMUM SIZE OF COARSE AGGREGATE IN MILLIMETERS.
3. UNLESS OTHERWISE IN THE PLANS, LAP SPLICES FOR VERTICAL COLUMN REINFORCEMENT SHALL BE MADE WITHIN THE CENTER HALF OF COLUMN HEIGHT, AND THE SPLICE LENGTH SHALL NOT BE LESS THAN 40 BAR DIAMETERS. WELDING OR APPROVED MECHANICAL DEVICES MAY BE USED PROVIDED THAT NOT MORE THAN ALTERNATE BARS ARE WELDED OR MECHANICALLY SPLICED AT ANY LEVEL AND THE VERTICAL DISTANCES BETWEEN THESE WELDS OR SPLICES OF ADJACENT BARS IS NOT LESS THAN 600mm.

### NOTES ON BEAMS AND GIRDERS

1. IF THE BEAM REINFORCING BARS END IN A WALL THE CLEAR DISTANCE FROM THE BAR TO THE FARTHER FACE OF THE WALL NOT BE LESS THAN 25mm. TOP BAR SHALL NOT BE SPLICED WITHIN THE COLUMN OR WITHIN A DISTANCE TWICE THE MEMBER DEPTH FROM THE FACE OF THE COLUMN. AT LEAST TWO STIRRUPS SHALL BE PROVIDED AT ALL SPLICES.
2. WHEN A BEAM CROSSES A GIRDER, REST BEAM ON TOP OF GIRDER BARS, BEAM REINFORCING BAR SHALL SYMMETRICAL ABOUT CENTER LINE WHENEVER POSSIBLE.
3. GENERALLY NO SPLICES SHALL BE PERMITTED AT POINTS WHERE CRITICAL BENDING STRESSES OCCUR. WELDED SPLICES SHALL DEVELOP IN TENSION AT LEAST 125 % OF THE SPECIFIED YIELDS STRENGTH OF THE BAR NOT MORE THAN 50 % OF THE BARS AT ANY ONE SECTION IS ALLOWED TO BE SPLICED THEREIN.

### NOTES ON FOOTING

1. FOOTING ARE DESIGNED BASED ON SITE ALLOWABLE BEARING CAPACITY.
2. FOOTING SHALL REST AT LEAST 1200mm BELOW NATURAL GRADE LINE UNLESS OTHERWISE INDICATED IN PLANS. NO FOOTING SHALL REST ON FILL.
3. MINIMUM CONCRETE PROTECTION FOR REINFORCEMENTS SHALL BE 75mm CLEAR FOR CONCRETE DEPOSITED THE GROUND AND 50mm FOR CONCRETE DEPOSITED AGAINST A FORMWORK.

### NOTES ON CONCRETE MIXES & PLACING

1. ALL CONCRETE SHALL DEVELOP A MIN. COMPRESSIVE STRENGTH AT THE END OF TWENTY EIGHT (28) DAYS WITH CORRESPONDING MINIMUM SIZES AGGREGATE & SLUMPS AS FOLLOWS.

LOCATION	28 DAYS STRENGTH	MAX. SIZES OF AGGREGATE	MAX. SLUMP
ALL OTHERS, INCLUDING SUSPENDED SLABS, COLUMN	4000 PSI (27.6 MPa)	20mm	100mm
BEAMS, SLABS	4000 PSI (27.6 MPa)	20mm	100mm
SLAB ON FILL	3000 PSI (20.7 MPa)	20mm	100mm

2. MAINTAIN A MINIMUM CONCRETE COVER FOR REINFORCING STEEL AS FOLLOWS.
 

SUSPENDED SLABS	20mm
SLAB ON GRADE	40mm
WALLS ABOVE GRADE	25mm
BEAM STIRRUPS AND COLUMN TIES WHERE TO CONCRETE IS EXPOSED TO EARTH BUT POURED AGAINST FORMS WHERE CONCRETE IS DEPOSITED DIRECTLY AGAINST EARTH	50mm
	75mm

3. CONCRETE SHALL BE DEPOSITED IN ITS FINAL POSITION WITHOUT SEGREGATION. RE-HANDLING OR PLACING SHALL BE DONE PREFERABLY WITH BUCKETS, BUCKETS OR WHEELBARROWS, NO CHUTES WILL BE ALLOWED EXCEPT TO TRANSFER CONCRETE FROM HOPPERS TO BUCKETS, WHEELBARROWS OR BUCKETS IN WHICH CASE THEY SHALL NOT EXCEED SIX (6) METERS IN AGGREGATE LENGTH.

4. NO DEPOSITING OF CONCRETE SHALL BE ALLOWED WITHOUT THE USE OF VIBRATORS UNLESS AUTHORIZED IN WRITING BY THE DESIGNERS AND ONLY FOR UNUSUAL CONDITION WHERE VIBRATORS WHERE EXTREMELY DIFFICULT TO ACCOMPLISH.

5. ALL ANCHOR BOLTS, DOWELS AND OTHER INSERTS, SHALL BE PROPERLY POSITIONED & SECURED IN PLACE PRIOR TO PLACING OF CONCRETE.

6. ALL CONCRETE SHALL BE KEPT MOIST FOR A MINIMUM OF SEVEN CONSECUTIVE DAYS IMMEDIATELY AFTER POURING BY THE USE OF WET BURLAP, FOG SPRAYING, CURING COMPOUNDS OR OTHER APPROVED METHODS.

STRIPPING OF FORMS AND SHORES:	24 HRS
FOUNDATION	
SUSPENDED SLAB EXCEPT WHEN ADDITIONAL LOADS ARE IMPOSED	8 DAYS
WALLS	21 DAYS
BEAMS	14 DAYS
COLUMNS	21 DAYS

8. THE CONTRACTOR SHALL FURNISH AND MAINTAIN ADEQUATE FORMS AND SHORING UNTIL THE CONCRETE MEMBERS HAVE ATTAINED THEIR WORKING CONDITION AND STRENGTH.

### NOTES ON CONCRETE HOLLOW BLOCK WALLS

1. UNLESS OTHERWISE SHOWN IN PLANS ALL CONCRETE HOLLOW BLOCKS AND CERAMIC BLOCKS SHALL BE REINFORCED AS SHOWN IN THE SCHEDULE OF CONCRETE HOLLOW BLOCKS AND CERAMIC BLOCK REINFORCEMENT.

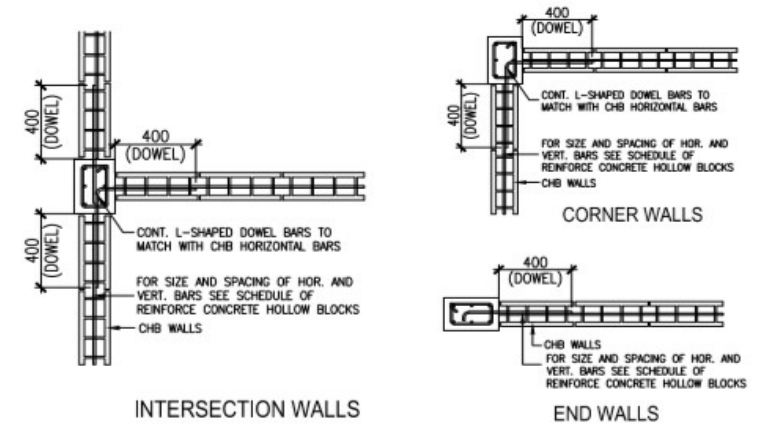

INTERSECTION WALLS

END WALLS

TYPICAL CONNECTION DETAIL OF MASONRY

BLOCK THICKNESS	STEEL REINFORCEMENTS		NOTES
	HORIZONTAL	VERTICAL	
100 mm	10mm $\phi$ @ 600mm O.C.	12mm $\phi$ @ 600mm O.C.	A. MINIMUM LAPS SPLICE = 0.25m B. PROVIDE RIGHT ANGLED REINFORCEMENT AT CORNERS 0.92M LONG
150 mm	10mm $\phi$ @ 600mm O.C.	12mm $\phi$ @ 600mm O.C.	C. WHERE CHB OR CER. BLK. WALL DOWELS JOIN COL. R.C. BEAMS AND WALL DOWELS WITH THE SAME SIZE AS VERT. OR HOR. REINFORCEMENTS SHALL BE PROVIDED
200 mm	10mm $\phi$ @ 600mm O.C.	12mm $\phi$ @ 600mm O.C.	

### NOTES ON WELDS

1. WELDING ELECTRODES SHALL CONFORM TO AWS A-5.1 OR 5.5; E70 ELECTRODES.
2. WELDS SHALL DEVELOP THE FULL STRENGTH OF MEMBERS JOINED UNLESS OTHERWISE SHOWN OR DETAILED IN THE DRAWINGS.

### NOTES ON STRUCTURAL STEEL

1. STRUCTURAL STEEL TO BE USED FOR FABRICATION AND ERECTION OF THIS STRUCTURE SHALL COMPLY WITH ALL THE PERTINENT PROVISION OF AISC SPECIFICATION FOR THE DESIGN, FABRICATION AND ERECTION OF STRUCTURAL STEEL FOR BUILDING LATEST EDITION OTHERWISE INDICATED.
2. ALL WELDED CONNECTIONS SHALL DEVELOP THE FULL STRENGTH OF THE MEMBERS CONNECTED.

	PROJECT TITLE	RECOMMENDING APPROVAL	APPROVED BY	NCR TEAM	SHEET CONTENT	SHEET NO.
	REPAIR OF PERIMETER FENCE AT SSS EAST TRIANGLE PROPERTY LOCATION: East Triangle Property, East Ave., Brgy. Payuhan, Diliman, Quezon City	SLANK O. ESPINO CEO NCR-TMS	WENDELIN V. CONOLLY JR. ACTING HEAD, GENERAL SUPERVISOR DIVISION CONSTRUCTION DIVISION	DRIVEN BY: DARYL JOHN L. TREADO - ACTING SSO N	- General Construction Notes	S-1 DATE: APR. 18, 2024

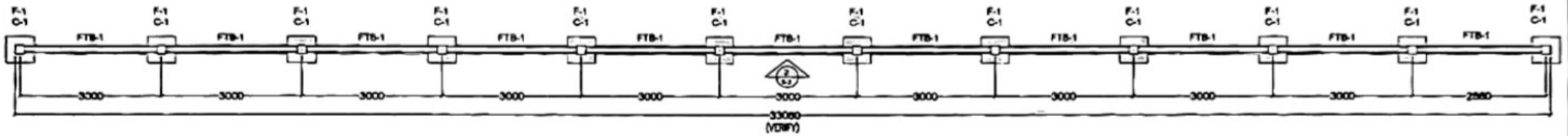

**1** FOUNDATION PLAN  
**S-2** SCALE: 1:85

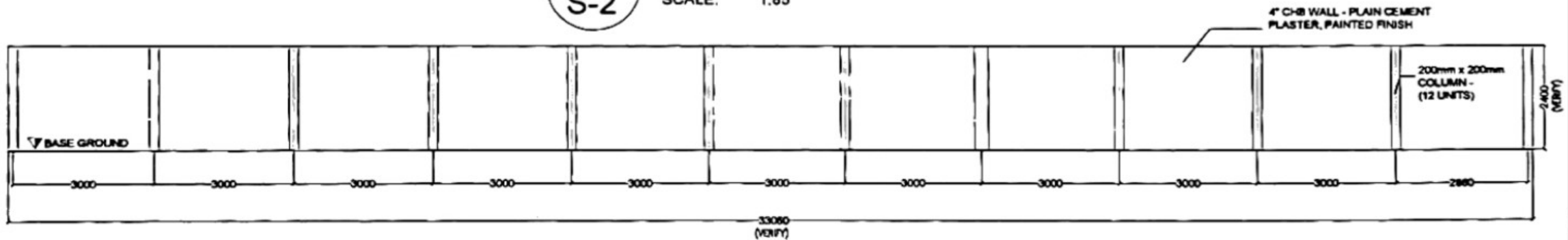

**2** FRONT ELEVATION  
**S-2** SCALE: 1:85

	<b>PROJECT TITLE:</b> REPAIR OF PERIMETER FENCE AT SSS EAST TRIANGLE PROPERTY	<b>RECOMMENDING APPROVAL:</b>  CLARIBEL ESPINO CE01-FM-1	<b>APPROVED BY:</b>  WENDELINO V. OJEDA, JR. ACTING HEAD GENERAL MANAGER/ASSISTANT COMMUNITY ACQUISITION DIVISION	<b>NCR TEAM:</b> DRAWN BY:  DARYL JOHN A. TRINIDAD - ACTING SSG N	<b>SHEET CONTENTS:</b> - Foundation Plan - Front Elevation	<b>SHEET NO.:</b> S-2
	<b>SOCIAL SECURITY SYSTEM</b> LOCATION: East Triangle Property, East Ave., Bgo, Payaman, Davao, Davao City	REVISIONS: NO.   DATE   BY   DESCRIPTION		DATE: MAY 14, 2024		

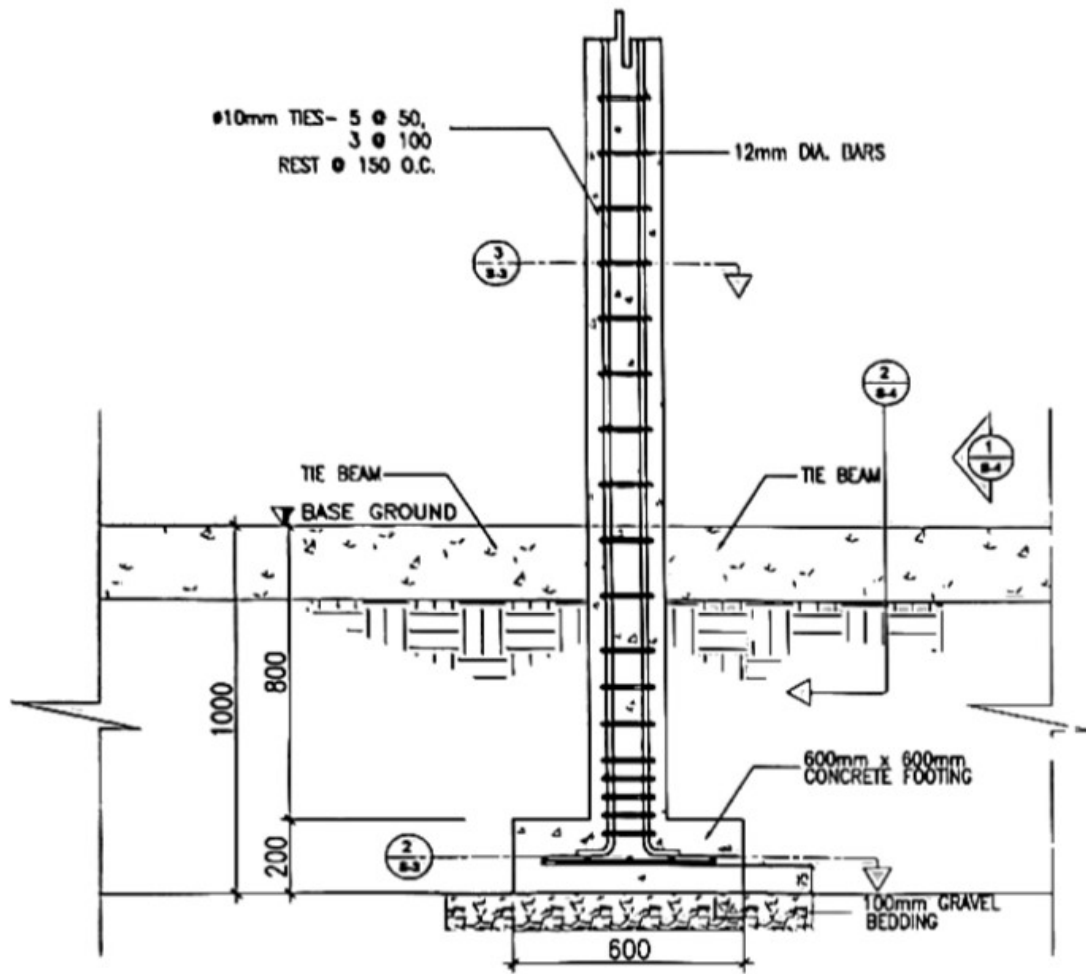

**1**  
S-3  
**FOUNDATION DETAILS**  
SCALE: 1:15

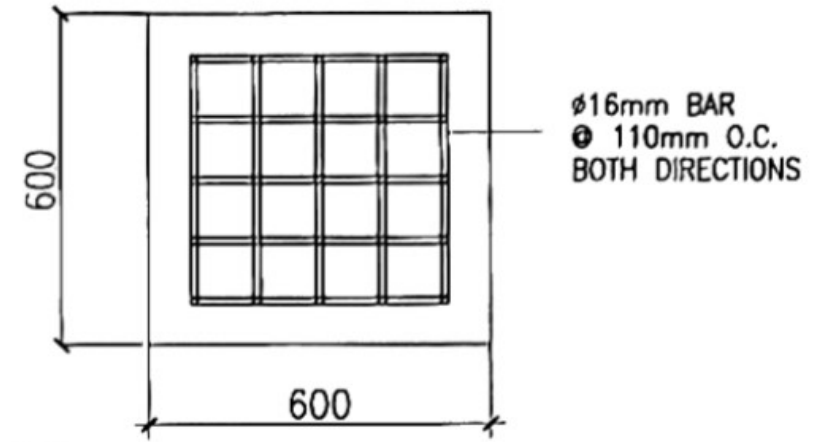

**2**  
S-3  
**FOOTING DETAILS**  
SCALE: 1:10

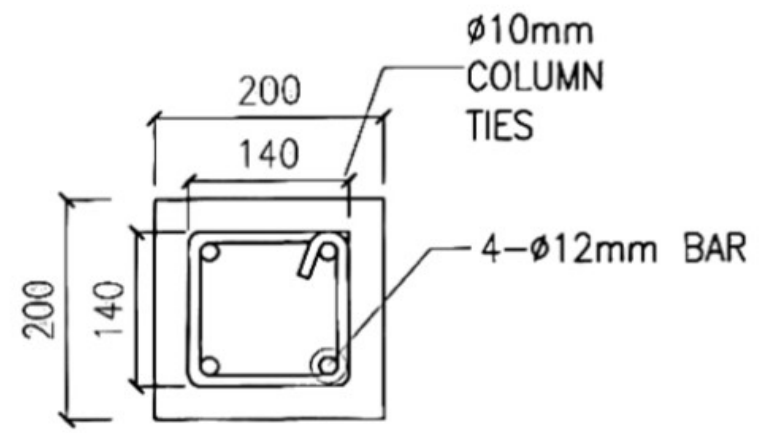

**3**  
S-3  
**COLUMN DETAILS**  
SCALE: 1:5

<p>ENGINEERING AND FACILITIES MANAGEMENT DEPARTMENT</p> <p>SOCIAL SECURITY SYSTEM</p>	<p>PROJECT TITLE</p> <p><b>REPAIR OF PERIMETER FENCE AT SSS EAST TRIANGLE PROPERTY</b></p>	<p>RECOMMENDING APPROVAL</p> <p><i>[Signature]</i> CARLOS ESPERO CON. ASST.</p>	<p>APPROVED BY</p> <p><i>[Signature]</i> WENDELINO V. COMETA, JR. ACTING HEAD GENERAL SERVICES DIVISION CONCERNED ACTING HEAD, EPMU</p>	<p>NCR TEAM</p> <p>DRAWN BY: <i>[Signature]</i> GAYLL JOYPA / TRINIDAD - ACTING SSO IV</p>	<p>SHEET CONTENT:</p> <p>- Footing Details - Column Details</p>	<p>SHEET NO.</p> <p><b>S-3</b></p>
	<p>LOCATION: East Triangle Property, East Ave., Brgy. Pinyahan, Diliman, Quezon City</p>					



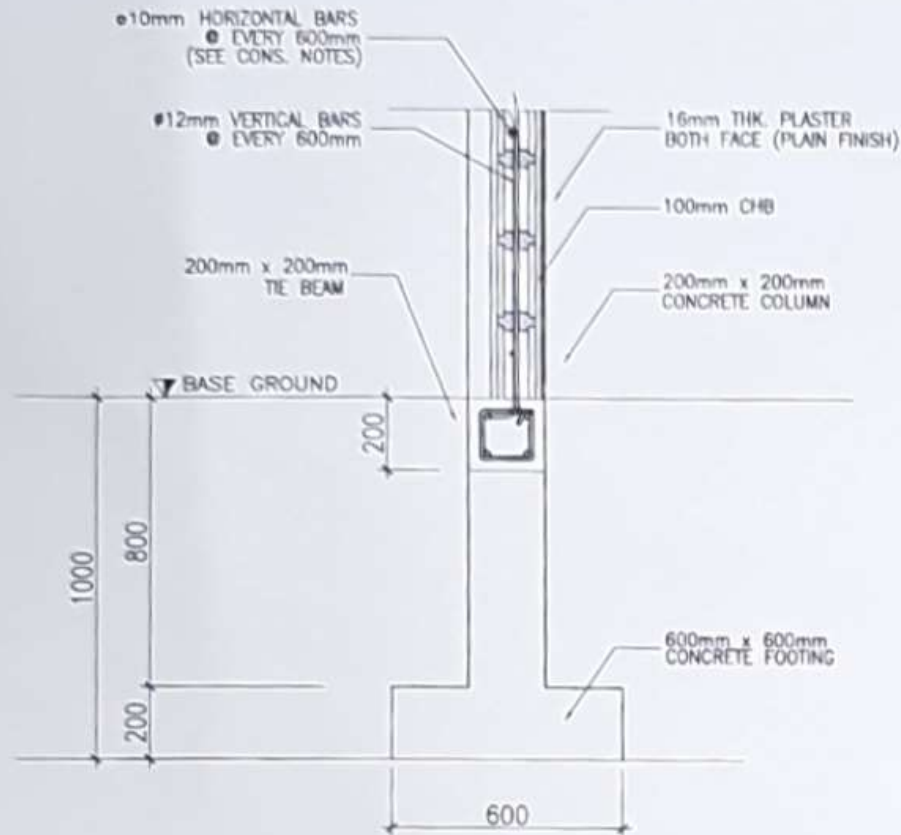

**1**  
**S-4** TIE BEAM DETAILS  
SCALE: 1:15

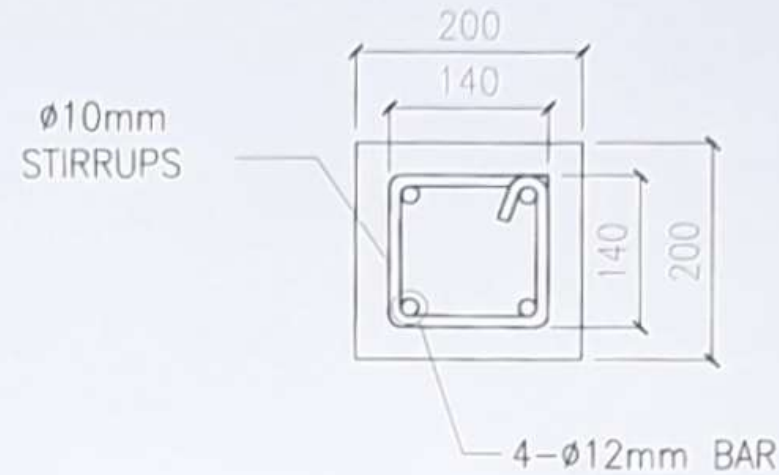

**2**  
**S-4** TIE BEAM (SECTION)  
SCALE: 1:5

BEAM SCHEDULE											
BEAM MARK	BEAM DIMENSIONS (mm)		STEEL REINFORCEMENT						STIRRUPS Ø10mm (UNLESS NOTED OTHERWISE)	REMARKS	
			REBAR (Ømm)	LEFT		MID SPAN		RIGHT			
	b	h		TOP	BOT.	TOP	BOT.	TOP	BOT.		
FTB-1	200	200	Ø12mm	2	2	2	2	2	2	1Ø50, 6Ø100, RESTØ200	REINFORCED CONCRETE (RC)

<p>ENGINEERING AND FACILITIES MANAGEMENT DEPARTMENT</p> <p><b>SOCIAL SECURITY SYSTEM</b></p>	<p>PROJECT TITLE</p> <p><b>REPAIR OF PERIMETER FENCE AT SSS EAST TRIANGLE PROPERTY</b></p> <p>LOCATION: East Triangle Property, East Ave., Brgy. Pinyahan, Dikhan, Guzman City</p>	<p>RECOMMENDING APPROVAL</p> <p><i>[Signature]</i></p> <p>CE/EN-748</p>	<p>APPROVED BY</p> <p><i>[Signature]</i></p> <p>VENEDICTO P. V. COMBAYO ACTING HEAD GENERAL SERVICES DIVISION CONSTRUCTION MANAGEMENT GROUP</p>	<p>NCR TEAM</p> <p>DRAWN BY: <i>[Signature]</i> DARYLL JOYNT L. FERRER - ACTING SSO IV</p>	<p>SHEET CONTENT</p> <ul style="list-style-type: none"> <li>- Tie Beam Details</li> <li>- Tie Beam (Section)</li> <li>- Beam Schedule</li> </ul>	<p>ALL DIMENSIONS UNLESS OTHERWISE SPECIFIED ARE IN MILLIMETERS</p> <p>DATE: 11/11/2024</p> <p>SCALE: 1:15</p>	<p>SHEET NO.</p> <p><b>S-4</b></p>
--	--	---	---	--	--	--	------------------------------------